



User Manual



Click the link <https://www.ezviz.com/page/hg3-300-Pro-choose-language> or scan the QR code to watch the tutorial videos.

www.ezviz.com

COPYRIGHT © Hangzhou EZVIZ Software Co., Ltd. ALL RIGHTS RESERVED.

Any and all information, including, among others, wordings, pictures, graphs are the properties of Hangzhou EZVIZ Software Co., Ltd. (hereinafter referred to as "EZVIZ"). This user manual (hereinafter referred to as "the Manual") cannot be reproduced, changed, translated, or distributed, partially or wholly, by any means, without the prior written permission of EZVIZ. Unless otherwise stipulated, EZVIZ does not make any warranties, guarantees or representations, express or implied, regarding to the Manual.

About this Manual

The Manual includes instructions for using and managing the product. Pictures, charts, images and all other information hereinafter are for description and explanation only. The information contained in the Manual is subject to change, without notice, due to firmware updates or other reasons. Please find the latest version in the EZVIZ™ website (<http://www.ezviz.com>).

Revision Record

New release - January, 2026

Trademarks Acknowledgement

EZVIZ™, ™ and other EZVIZ's trademarks and logos are the properties of EZVIZ in various jurisdictions. Other trademarks and logos mentioned below are the properties of their respective owners.

Legal Disclaimer

TO THE MAXIMUM EXTENT PERMITTED BY APPLICABLE LAW, THE PRODUCT DESCRIBED, WITH ITS HARDWARE, SOFTWARE AND FIRMWARE, IS PROVIDED "AS IS", WITH ALL FAULTS AND ERRORS, AND EZVIZ MAKES NO WARRANTIES, EXPRESS OR IMPLIED, INCLUDING WITHOUT LIMITATION, MERCHANTABILITY, SATISFACTORY QUALITY, FITNESS FOR A PARTICULAR PURPOSE, AND NON-INFRINGEMENT OF THIRD PARTY. IN NO EVENT WILL EZVIZ, ITS DIRECTORS, OFFICERS, EMPLOYEES, OR AGENTS BE LIABLE TO YOU FOR ANY SPECIAL, CONSEQUENTIAL, INCIDENTAL, OR INDIRECT DAMAGES, INCLUDING, AMONG OTHERS, DAMAGES FOR LOSS OF BUSINESS PROFITS, BUSINESS INTERRUPTION, OR LOSS OF DATA OR DOCUMENTATION, IN CONNECTION WITH THE USE OF THIS PRODUCT, EVEN IF EZVIZ HAS BEEN ADVISED OF THE POSSIBILITY OF SUCH DAMAGES.

TO THE MAXIMUM EXTENT PERMITTED BY APPLICABLE LAW, IN NO EVENT SHALL EZVIZ'S TOTAL LIABILITY FOR ALL DAMAGES EXCEED THE ORIGINAL PURCHASE PRICE OF THE PRODUCT.

EZVIZ DOES NOT UNDERTAKE ANY LIABILITY FOR PERSONAL INJURY OR PROPERTY DAMAGE AS THE RESULT OF PRODUCT INTERRUPTION OR SERVICE TERMINATION CAUSED BY: A) IMPROPER INSTALLATION OR USAGE OTHER THAN AS REQUESTED; B) THE PROTECTION OF NATIONAL OR PUBLIC INTERESTS; C) FORCE MAJEURE; D) YOURSELF OR THE THIRD PARTY, INCLUDING WITHOUT LIMITATION, USING ANY THIRD PARTY'S PRODUCTS, SOFTWARE, APPLICATIONS, AND AMONG OTHERS.

REGARDING TO THE PRODUCT WITH INTERNET ACCESS, THE USE OF PRODUCT SHALL BE WHOLLY AT YOUR OWN RISKS. EZVIZ SHALL NOT TAKE ANY RESPONSIBILITIES FOR ABNORMAL OPERATION, PRIVACY LEAKAGE OR OTHER DAMAGES RESULTING FROM CYBER ATTACK, HACKER ATTACK, VIRUS INSPECTION, OR OTHER INTERNET SECURITY RISKS; HOWEVER, EZVIZ WILL PROVIDE TIMELY TECHNICAL SUPPORT IF REQUIRED. SURVEILLANCE LAWS AND DATA PROTECTION LAWS VARY BY JURISDICTION. PLEASE CHECK ALL RELEVANT LAWS IN YOUR JURISDICTION BEFORE USING THIS PRODUCT IN ORDER TO ENSURE THAT YOUR USE CONFORMS TO THE APPLICABLE LAW. EZVIZ SHALL NOT BE LIABLE IN THE EVENT THAT THIS PRODUCT IS USED WITH ILLEGITIMATE PURPOSES.

IN THE EVENT OF ANY CONFLICTS BETWEEN THE ABOVE AND THE APPLICABLE LAW, THE LATTER PREVAILS.

Table of Contents

Safety Regulations	1
Overview	3
1. Package Contents	3
2. Necessary Materials (not provided)	5
3. Space Requirements	6
4. Field of Application	6
5. General View of Installation.....	6
6. Typical Connection.....	7
Prerequisites for Installation	9
1. Risk Analysis	9
1.1 Regulations.....	9
1.2 Specifications of the Gate Opener	9
1.3 Security Check on the Gate	9
1.4 Safety Rules	10
2. Risk Elimination.....	10
2.1 At Secondary Edges.....	10
2.2 At Lower Edges.....	11
2.3 Between Leaves and Fixed Parts Located Nearby.....	11
2.4 Prevention of Other Risks	11
Install the Wireless Repeater	12
1. Basics.....	12
2. Get the EZVIZ App	13
3. Choose an Installation Location.....	13
4. Plug in Wireless Repeater	14
5. Add Wireless Repeater to Your EZVIZ Account	15
6. Add Gate Opener to Your EZVIZ Account.....	16
Install Cylinder and Control Unit	17
1. Basics.....	17
2. Preparation	20
3. Install Pillar and Gate Fixing Brackets	22
4. Unlock the Cylinder	24
5. Fit the Cylinder onto the Gate and Pillar Fixing Bracket	25
6. Adjust Stop Blocks	26
7. Lock the Cylinder	28
8. Install Control Unit.....	28
9. Connect the Power Cable.....	29
10. Connect the Cylinder	29

Install the Photocellules	30
1. Components Required.....	30
2. Basics of Photocellules	30
3. Installation Procedure	30
Install the Alarm Light Camera	33
1. Components Required.....	33
2. Basics of Alarm Light Camera	33
3. Installation Procedure	34
Install Other Components (Optional)	39
1. Connect to Intercom Panel, Push Button or Key Switch.....	39
2. Connect to Customized Open Controller.....	40
3. Connect to Stop Sensor or Emergency Stop Button	40
4. Connect to Electric Strike Plate.....	41
5. Connect to Area Lighting	42
Preparatory Configuration	43
1. Wire Check	43
2. Power On the Gate Opener.....	43
3. Add the Remote Controller.....	44
4. Test the Photocellules.....	46
5. Test Gate Opening/Closing.....	47
6. Install the Backup Battery.....	48
7. Close the Gate Opener Cover	49
Settings	50
1. Wireless Repeater Management	50
1.1 Detail Page of Wireless Repeater.....	50
1.2 Wireless Repeater Settings	50
1.3 Binding a New Wireless Repeater	51
2. Gate Opener Management.....	53
2.1 Detail Page of Gate Opener	53
2.2 Gate Opener Settings.....	55
2.3 Speaker Settings	60
3. Alarm Light Camera Management	62
3.1 Live View.....	62
3.2 Camera Settings.....	63
3.3 Speaker Settings.....	64
Error Codes	65
Technical Data	67
Warranty	69
Help & Support	70
Initiatives on the Use of Video Products	71

Appendix..... 72

1. Rechargeable Lithium Ion Battery 72

2. Information for Private Households 72

Safety Regulations

We reserve the right to make any modifications to the technical, functional, or aesthetic characteristics of our products. This cylinder swing gate opener (hereinafter referred to as the "gate opener" or "device"), along with its user manual, has been designed to automate gate operation while complying with current European standards.

Precautions for use

- A gate opener is a product that can pose risks to people, animals, and property. For personal safety, it is essential to follow and retain these instructions.
- This device is suitable for use by children aged 8 years and older, as well as by individuals with reduced physical, sensory, or mental capabilities or limited experience and knowledge, provided they are under proper supervision, have been given instructions for safe use, and understand the associated risks. Children should not play with the device. Keep remote controls out of reach of children. Cleaning and maintenance should not be performed by children without supervision.
- This device must only be used for its intended purpose, which is to motorize a gate with one or two leaves for vehicle access. Any other use is considered dangerous.
- Gate opening or closing operations must be performed with clear visibility of the gate. If the gate is out of the user's line of sight, the installation must be equipped with a safety device, such as photocellules, and its proper functioning must be checked every six months.
- All potential users must be trained in the use of the gate opener by reading this manual. It is essential to ensure that no untrained person (such as a child) can operate the gate.
- Before setting the gate in motion, ensure that no one is in the gate's movement area.
- Avoid any natural obstacles (such as branches, stones, tall grass, etc.) that could impede the gate's movement.
- Do not manually operate the gate when the gate opener is not disconnected from the gate.
- Use of the device not in accordance with the instructions in this manual and resulting in damage will not hold the company EZVIZ responsible.

Installation precautions

- Read this manual thoroughly before beginning installation.
- The power supply for this gate opener must comply with current standards (including NFC 15-100) and must be performed by qualified personnel.
- The 100-240 V mains electricity supply must be protected by a suitable circuit breaker that meets current standards.
- All electrical connections must be made with the power off (protective trip in the OFF position) and the battery disconnected.
- Ensure that crushing and shearing between the moving parts of the motorized gate and the surrounding fixed parts are avoided or clearly signaled during the installation.
- If your gate does not have a crossbeam, please install one in advance.
- The gate should not be significantly tilted and must remain stable without swaying due to gravity when fully open or fully closed.
- The gate opener must be installed on a gate that meets the specifications outlined in this manual.
- The gate opener must not be installed in an environment with explosive conditions (e.g., presence of gas, flammable smoke, etc.).
- The installer must verify that the installation environment meets the temperature range requirements specified on the gate opener.
- The wire serving as the antenna must remain inside the electronic box.
- It is strictly prohibited to modify any of the components supplied in this kit or to use any additional elements not recommended in this manual.
- During installation, and especially during the adjustment of the gate opener, it is imperative to ensure that no person, including the installer, is in the

movement zone of the gate at the start and throughout the duration of the adjustment.

- The alarm light camera is an essential safety feature.
- If the installation does not match any of the cases described in this manual, it is essential to contact us so we can provide all the necessary elements for a safe and proper installation.
- After installation, ensure that the mechanism is correctly adjusted and that the protection systems, as well as the manual release device, are functioning properly.
- Do not allow children to play with fixed control devices. Keep remote control devices out of reach of children.
- The EZVIZ company cannot be held responsible for any damage if the installation is not carried out as specified in this manual.

Maintenance and cleaning

- It is essential to carefully read all the instructions provided in this manual before performing maintenance or cleaning on the gate opener.
- Disconnect the power supply during cleaning or maintenance operations, especially if the unit is controlled automatically.
- Any technical, electronic, or mechanical modifications to the gate opener must be approved by our technical department. Otherwise, the warranty will be immediately voided.
- In the event of a malfunction, the faulty part must be replaced with an original part only.
- Frequently inspect the installation to detect any defects in the gate or gate opener.
- Do not clean the product with abrasive or corrosive substances.
- Do not clean the product with a high-pressure cleaner.
- Use a simple, slightly damp soft cloth for cleaning.
- Do not spray this gate opener with an aerosol, as it could damage the interior components.

Battery usage warnings

- Disposing of a battery in a fire or a hot oven, or mechanically crushing or cutting a battery, can result in an explosion.
- Leaving a battery in an extremely high-temperature environment can lead to an explosion or the leakage of flammable liquid or gas.
- A battery exposed to extremely low air pressure may also result in an explosion or the leakage of flammable liquid or gas.

Overview

1. Package Contents

Cylinder Swing Gate Opener and Accessories

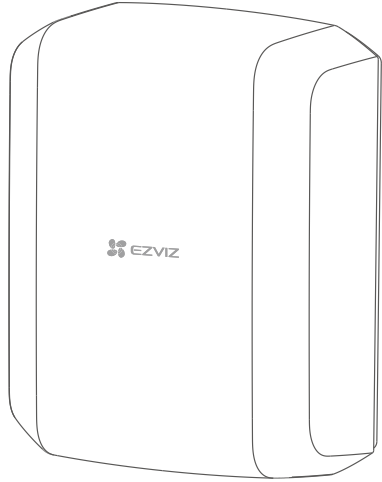

Control Unit (x1)

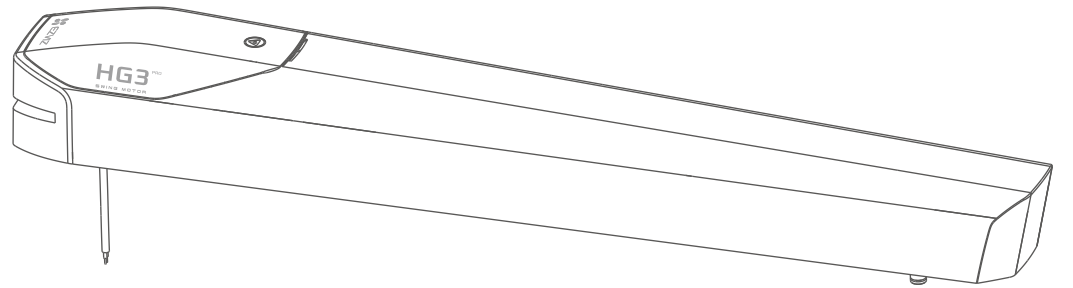

Cylinder (x2)

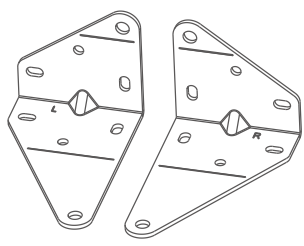

Pillar Fixing Bracket (x2)

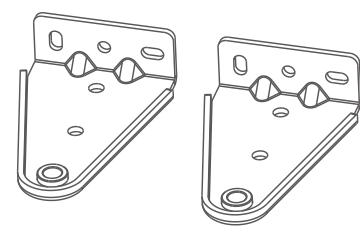

Gate Fixing Bracket (x2)

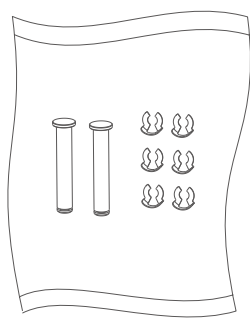

Toolkit (x1) *

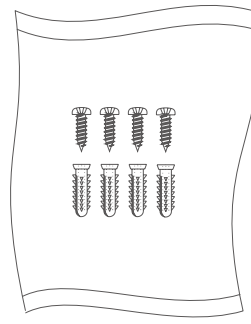

Screw Kit (x1) *

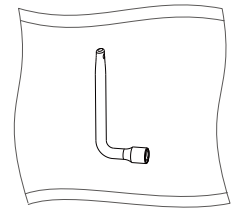

Key (x2)

Alarm Light Camera and Accessories

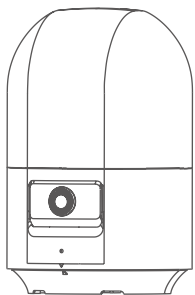

Alarm Light Camera (x1)

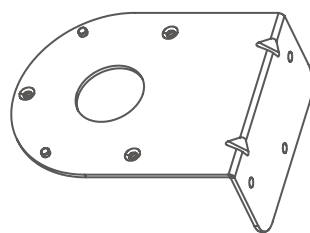

Wall Bracket (x1)

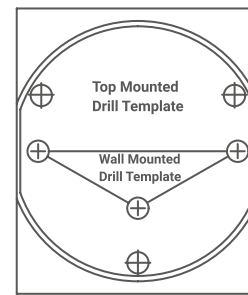

Drill Template (x1)

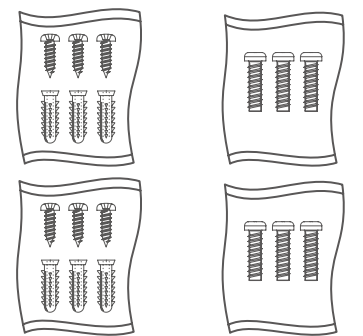

Screw Kit (x4) *

Photocellules and Accessories

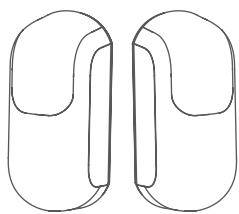

Photocellule (x2)

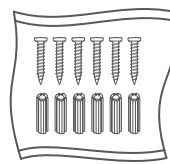

Screw Kit (x1) *

Others

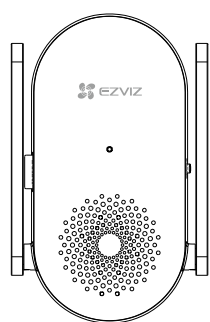

Wireless Repeater (x1)

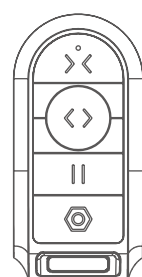

Remote Controller (x2) & Pin (x1)

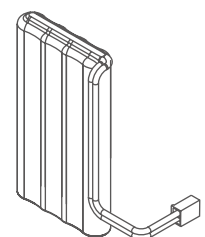

Backup Battery (x1)



Regulatory Information (x6)



Quick Start Guide (x1)

*** Toolkit of the Cylinder Swing Gate Opener**

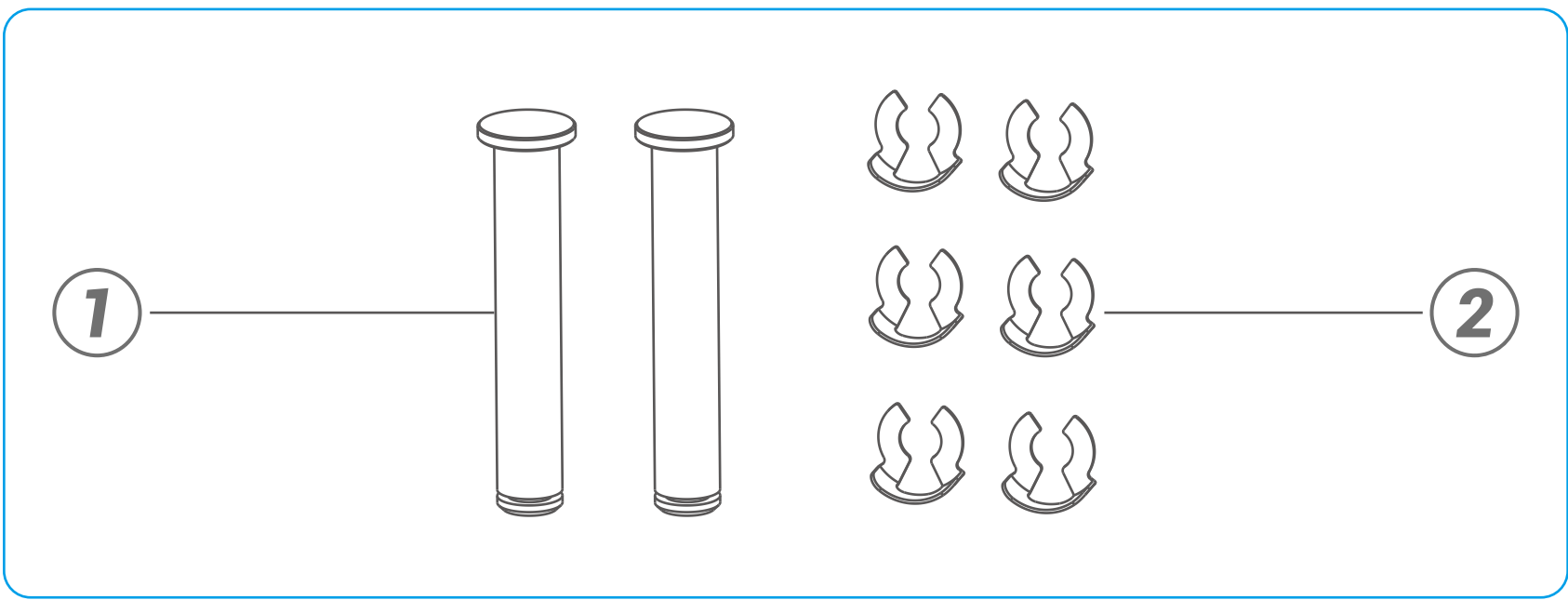

No.	Name	Quantity
1	Pivot pin	2
2	Retaining ring	6

*** Screw Kit of the Control Unit**

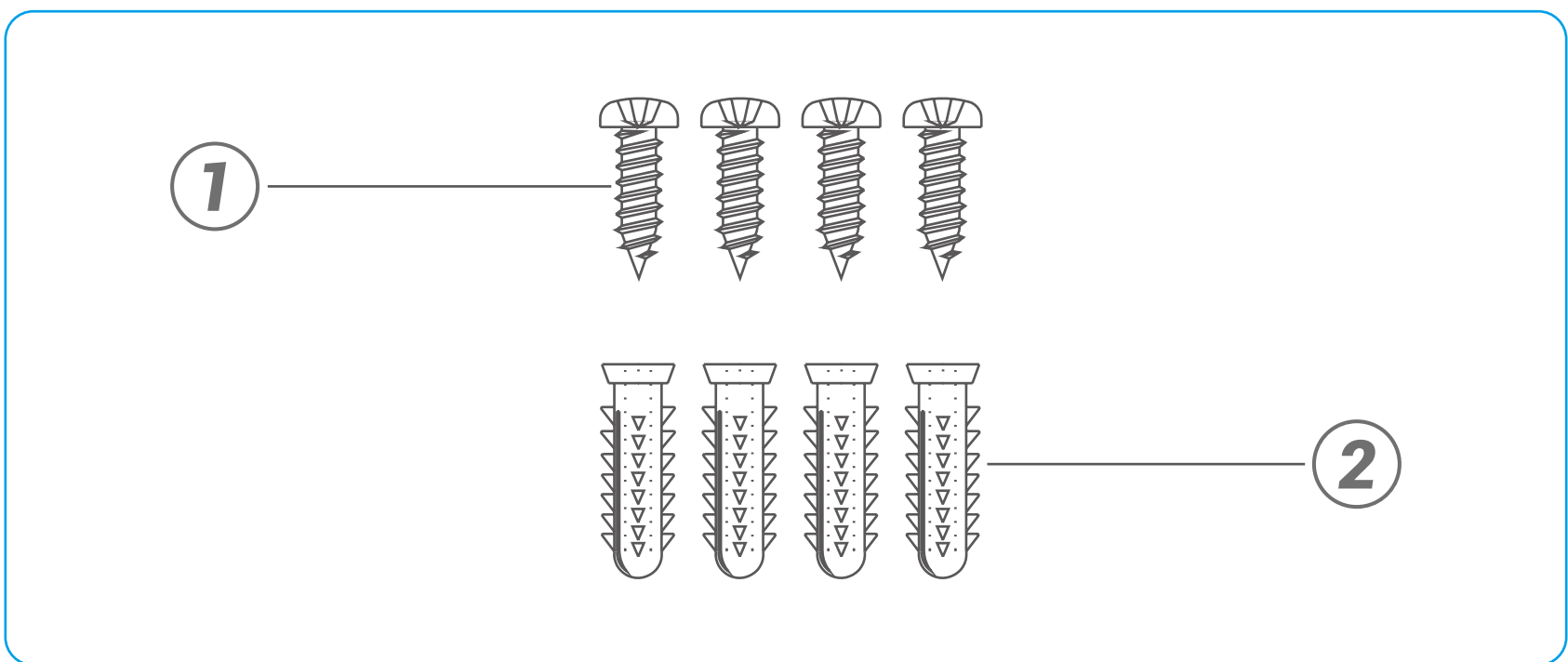

No.	Name	Quantity
1	PA4×25 Self-tapping Screw	4
2	5.5×25 Anchor	4

*** Screw Kit of the Alarm Light Camera**

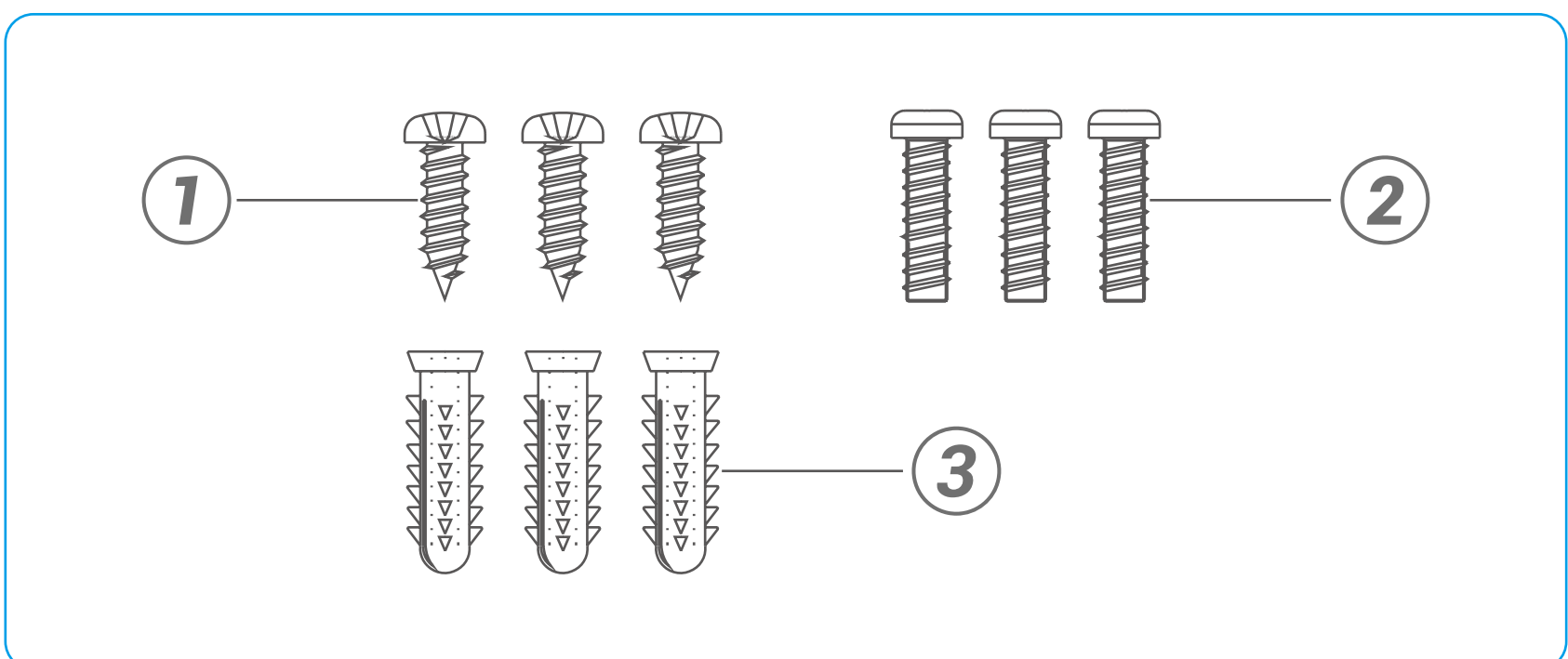

No.	Name	Quantity
1	PA3×25 Self-tapping Screw	3 per pack
2	M3×12 Pan-head Screw	3 per pack
3	6×25 Anchor	3 per pack

* Screw Kit of the Photocellule

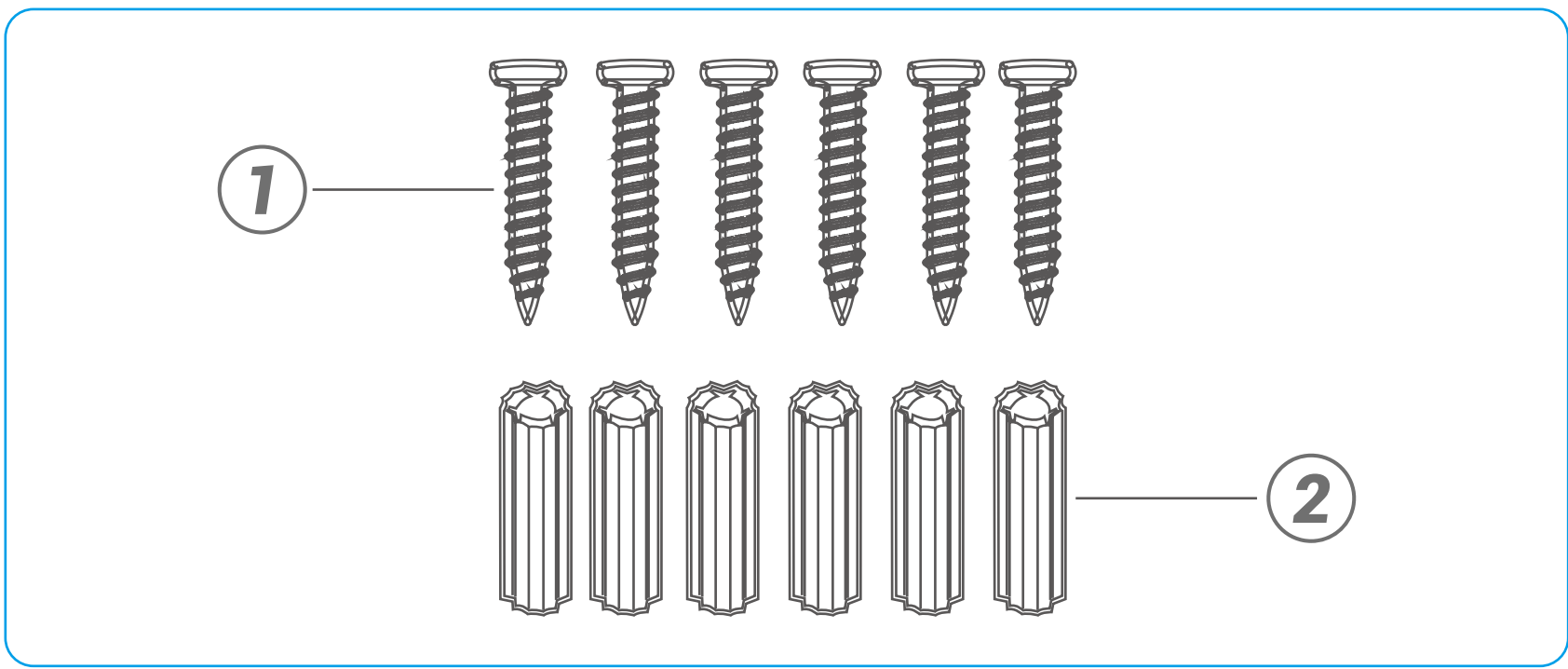

No.	Name	Quantity
1	KA3x20 Self-drilling Screw	6
2	6x25 Anchor	6

2. Necessary Materials (not provided)

The tools required for installation must be in good condition and comply with current safety standards.

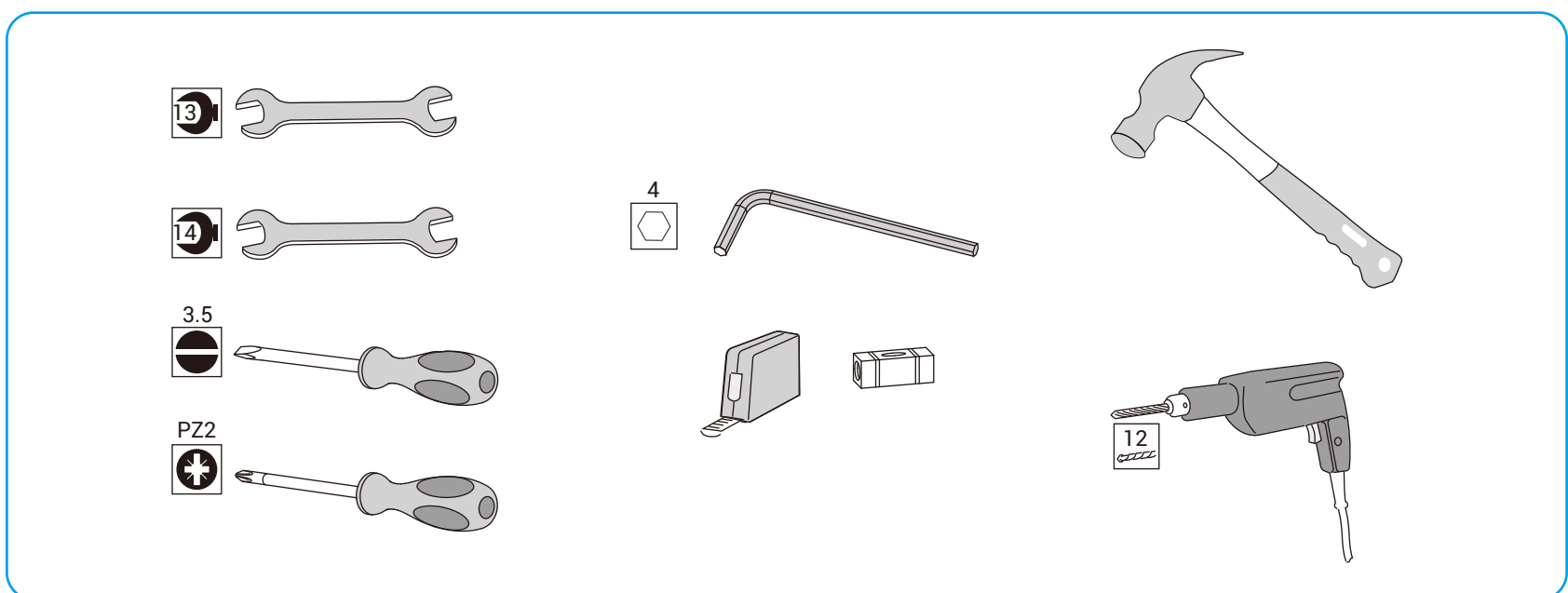

The cables used must be chosen for outdoor use. The passage of cables between the two pillars must comply with current standards. Recommended cable specifications are listed in the table below.

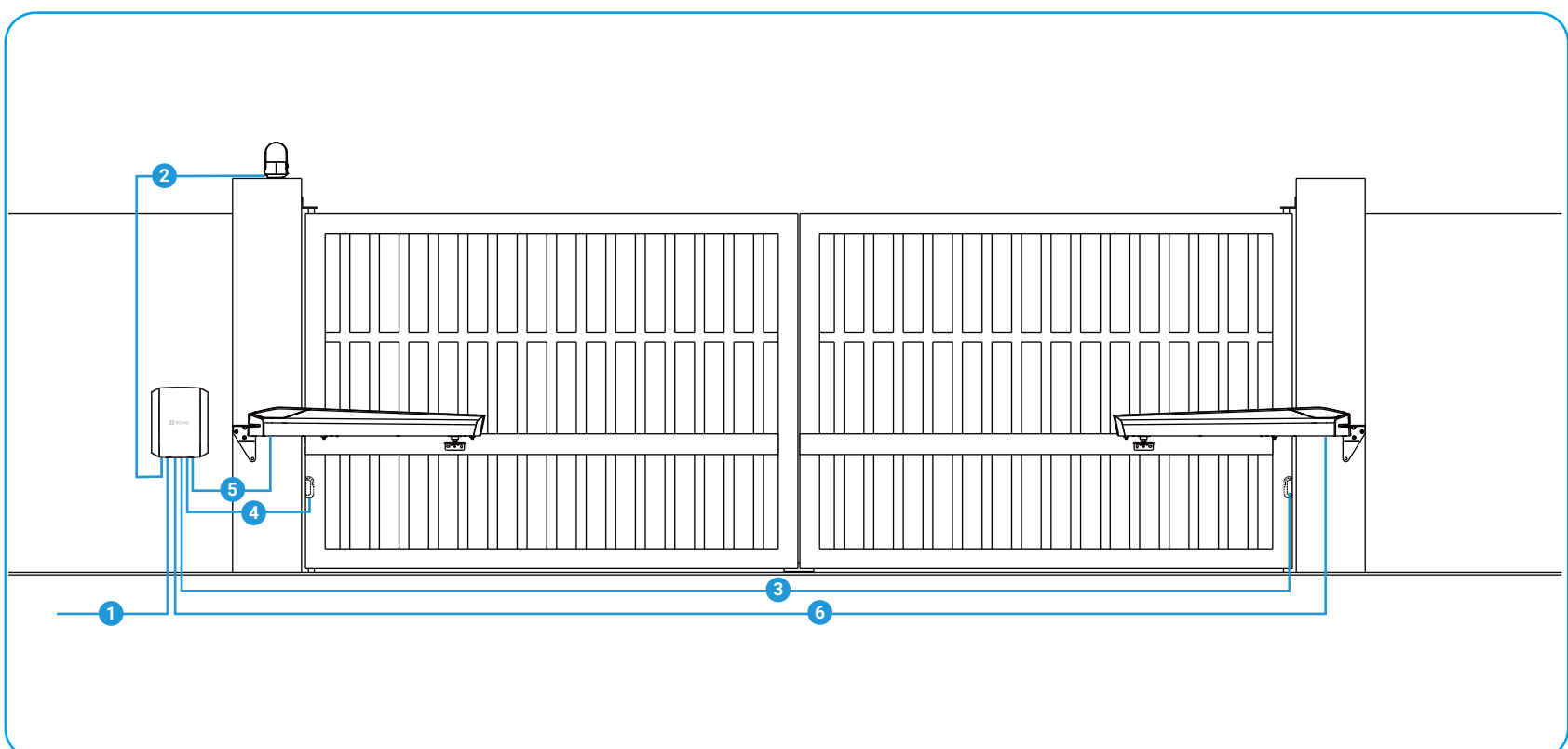

- The control unit should be installed on the side of the gate leaf that opens first (primary gate).
- The diagrams in this user manual use the control unit on the left side and the primary gate on the left as an example.

No.	Connection	Cable	Max Length
1	AC 100-240V Power Supply	3x1.5mm ²	Not Limited
2	Alarm Light Camera	2x0.75mm ² *	10m
3	Photocellule Transmitter (TX)	2x0.75mm ²	10m
4	Photocellule Receiver (RX)	2x0.75mm ²	10m

No.	Connection	Cable	Max Length
5	Left Cylinder	2×1.5mm ²	10m
6	Right Cylinder	2×1.5mm ²	10m

* For better signal anti-interference capability, it is recommended to use twisted-pair cables when connecting the alarm light camera.

3. Space Requirements

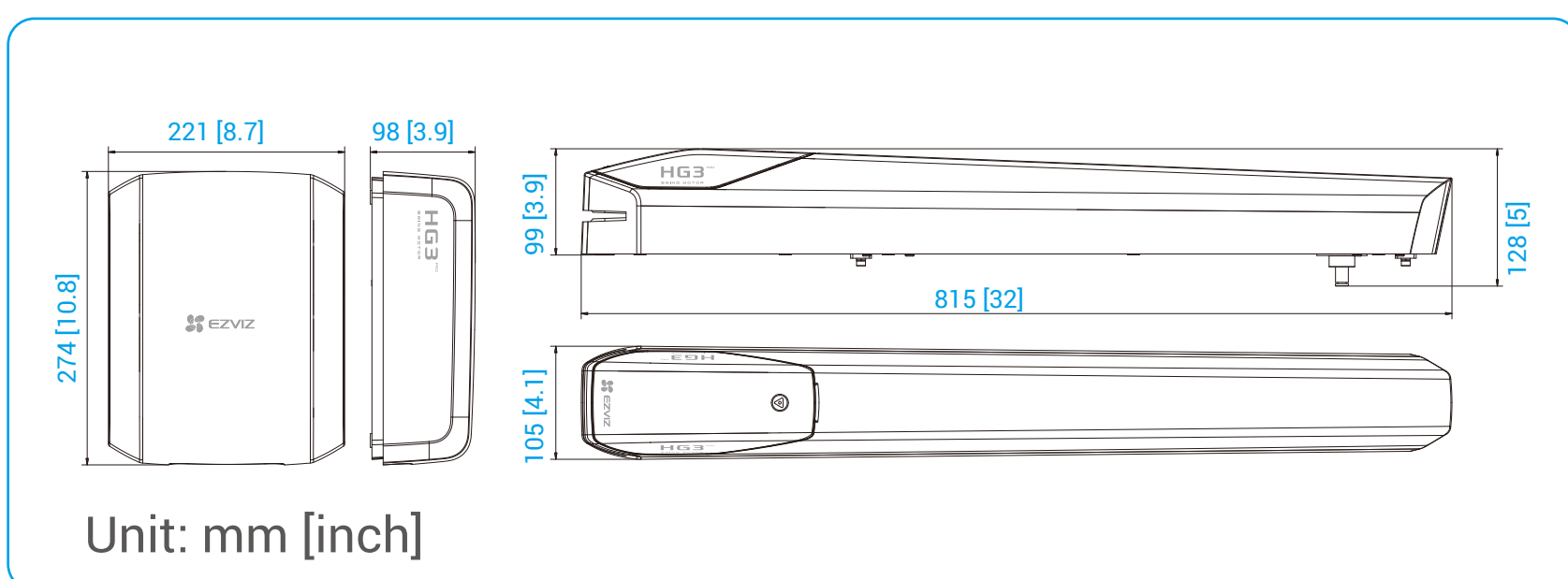

4. Field of Application

This product is intended for the driving of a two-leaf gate:

- measuring up to 3m wide and weighing up to 300kg
- in PVC, wood or metal
- for a detached house

5. General View of Installation

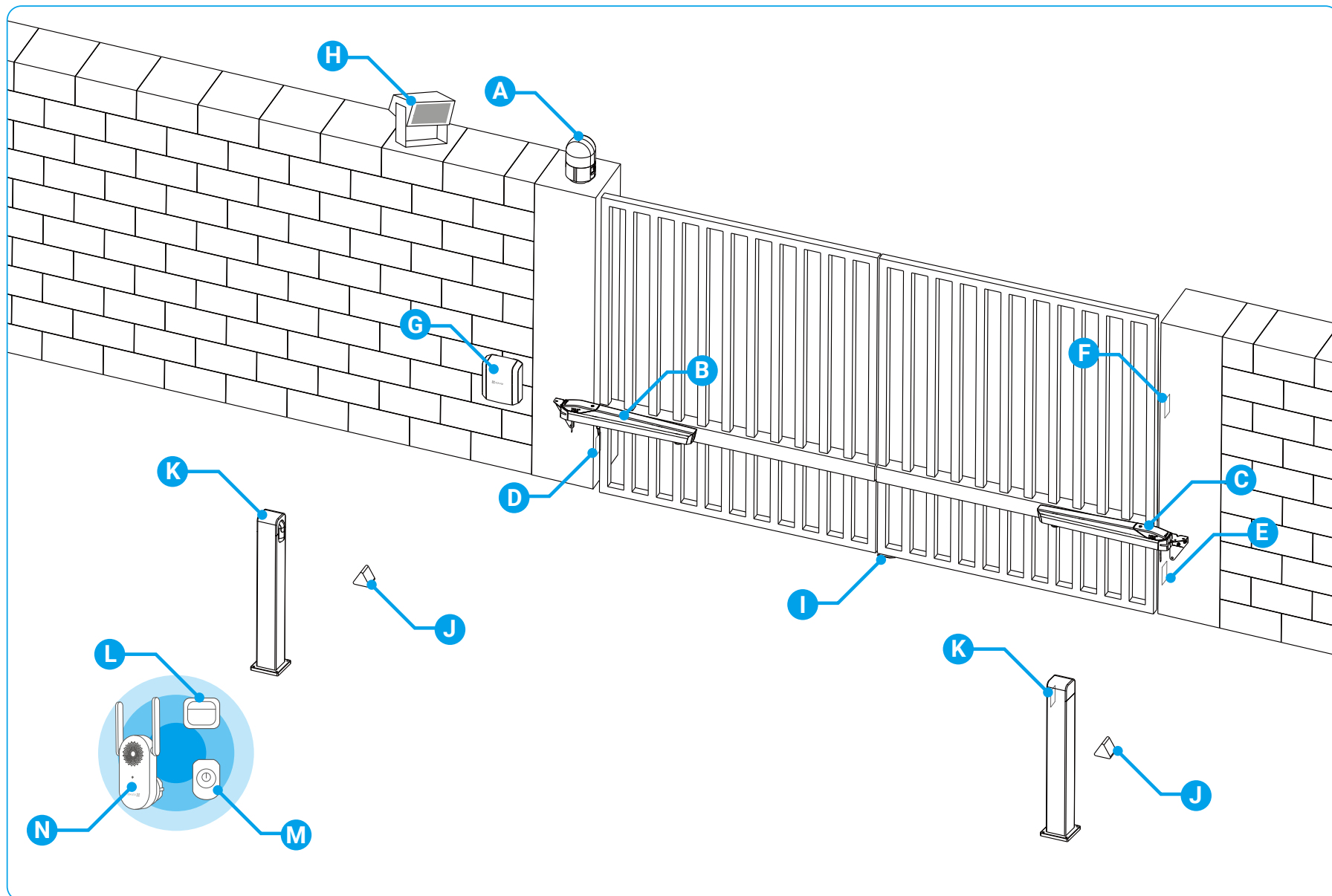

No.	Name	No.	Name
A	Alarm Light Camera	H	Area Lighting
B	Left Cylinder	I	Closing End Stop *
C	Right Cylinder	J	Opening End Stop *
D	Photocellule TX (or RX)	K	Internal Pedestal-mounted Photocellule *
E	Photocellule RX (or TX)	L	Push Button *
F	Intercom Panel *	M	Key Switch *

No.	Name	No.	Name
G	Control Unit	N	Wireless Repeater

* indicates the component is not included in the package.

6. Typical Connection

It is recommended to route the cables before starting the installation.

Cable routing must comply with current standards. Either the cable is 80cm deep with a red signaling fence, or the cable is passed through a sheath.

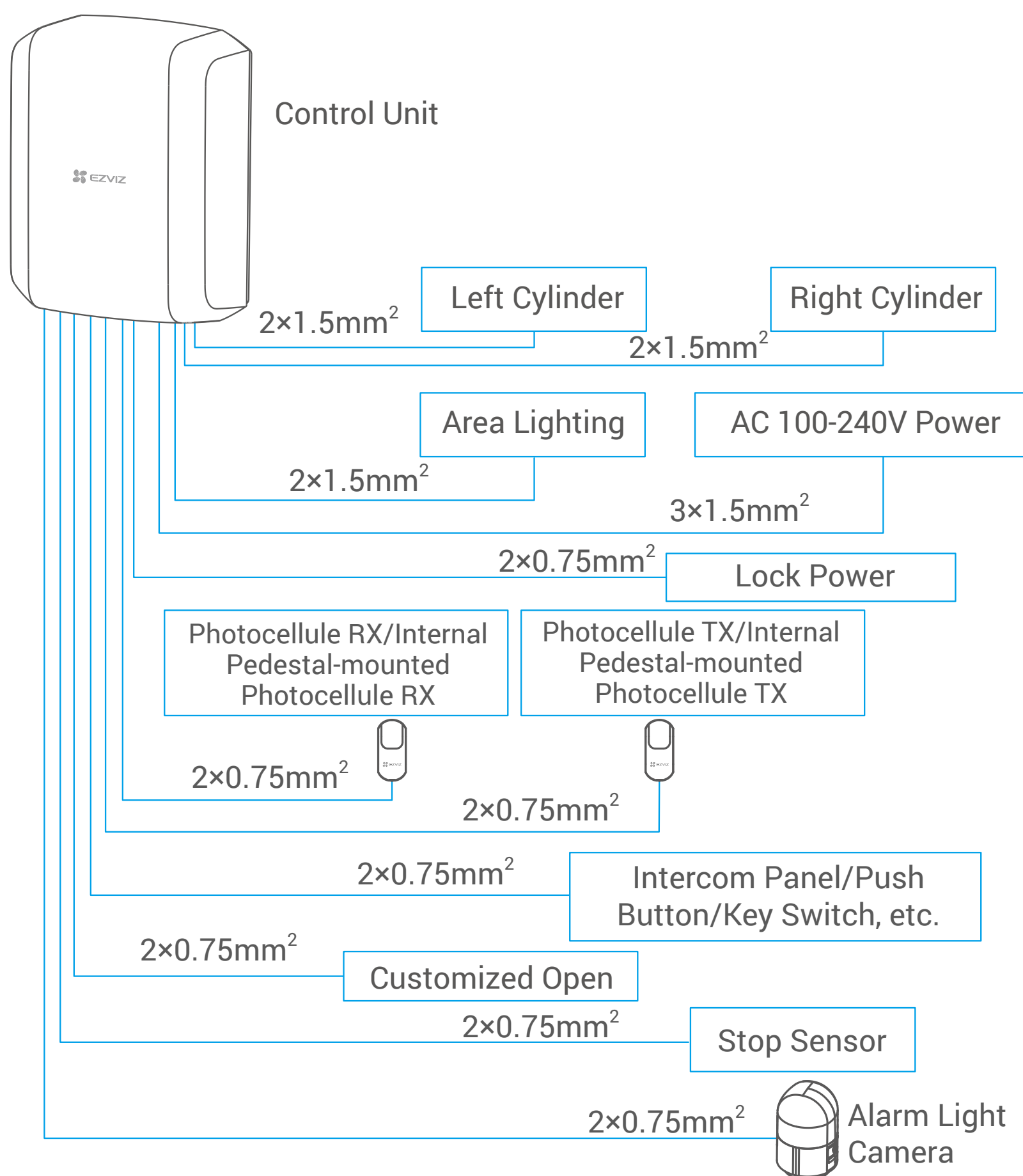

The "Cable connection instructions" label (inside the control unit) describes connections of the terminal blocks, as listed in the table below.

Cable connection instructions

Wiring Preparation

For more details on wiring, please refer to the electronic user manual.

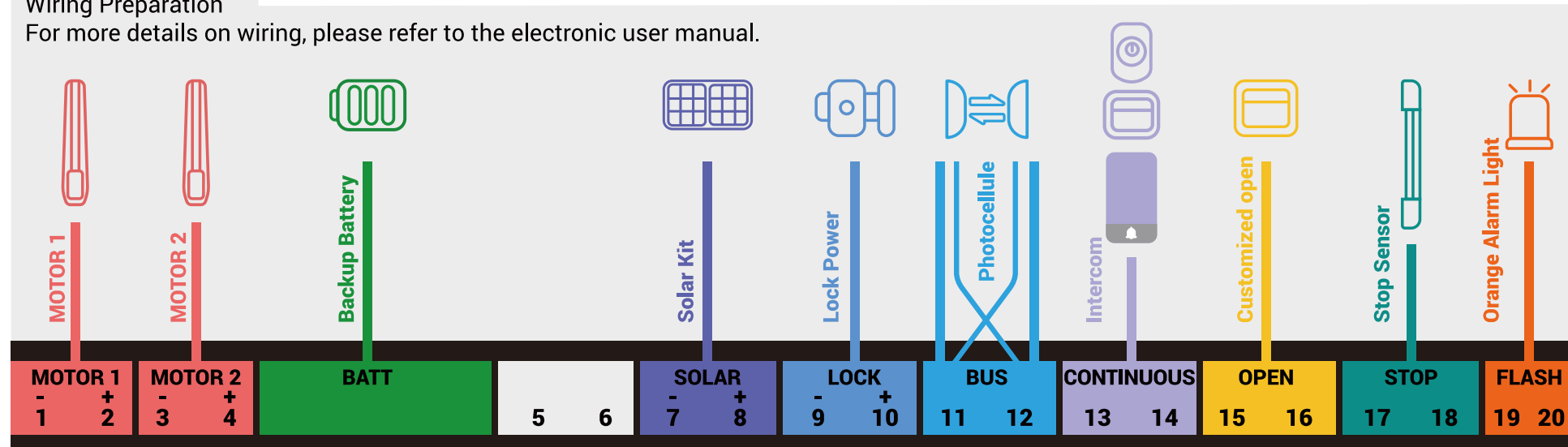

Terminals	Name	Description
1 & 2	MOTOR 1	Used to connect to the cylinder on the primary gate. i Red wire to positive, black wire to negative.
3 & 4	MOTOR 2	Used to connect to the other cylinder. i Red wire to positive, black wire to negative.
5 & 6	Reserved	

Terminals	Name	Description
7 & 8	SOLAR	Used to connect to the 24V solar kit. i Pay attention to polarity when connecting cables.
9 & 10	LOCK	Used to supply 12V DC power to an electric strike plate (without providing control signals). i Pay attention to polarity when connecting cables.
11 & 12	BUS	Used to connect to photocellules. i A maximum of 2 pairs of photocellules can be connected simultaneously. (The second pair is sold separately.)
13 & 14	CONTINUOUS	Used to connect to intercom panels, push buttons, or key switches to control the gate in the "Open-Stop-Close" sequence.
15 & 16	OPEN (Optional)	Used to connect to external control signals to open the gate. You can customize the opening mode (including fully open and only one leaf open) in the EZVIZ app.
17 & 18	STOP (Optional)	Used to connect to external control signals, such as a stop sensor. When hitting an obstacle, the gate will stop immediately.
19 & 20	FLASH	Used to connect to the alarm light camera.
	BATT	Used to connect to the backup battery. i Pay attention to polarity when connecting cables.

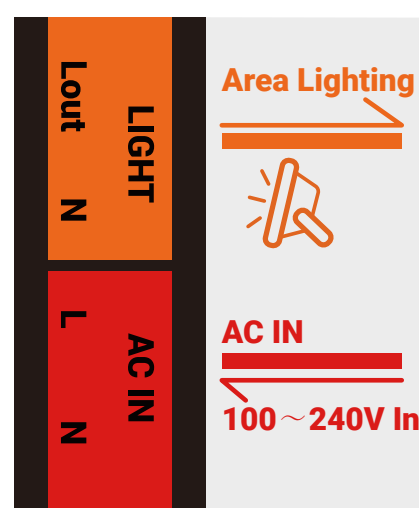

Name	Description	
LIGHT	N	Used to connect to the neutral wire for area lighting.
	Lout	Used to connect to the live wire for area lighting.
100-240V	N	Used to connect to the neutral wire of the power cable.
	L	Used to connect to the live wire of the power cable.
Earthing Rod	Used to connect to the earth wire of the power cable.	

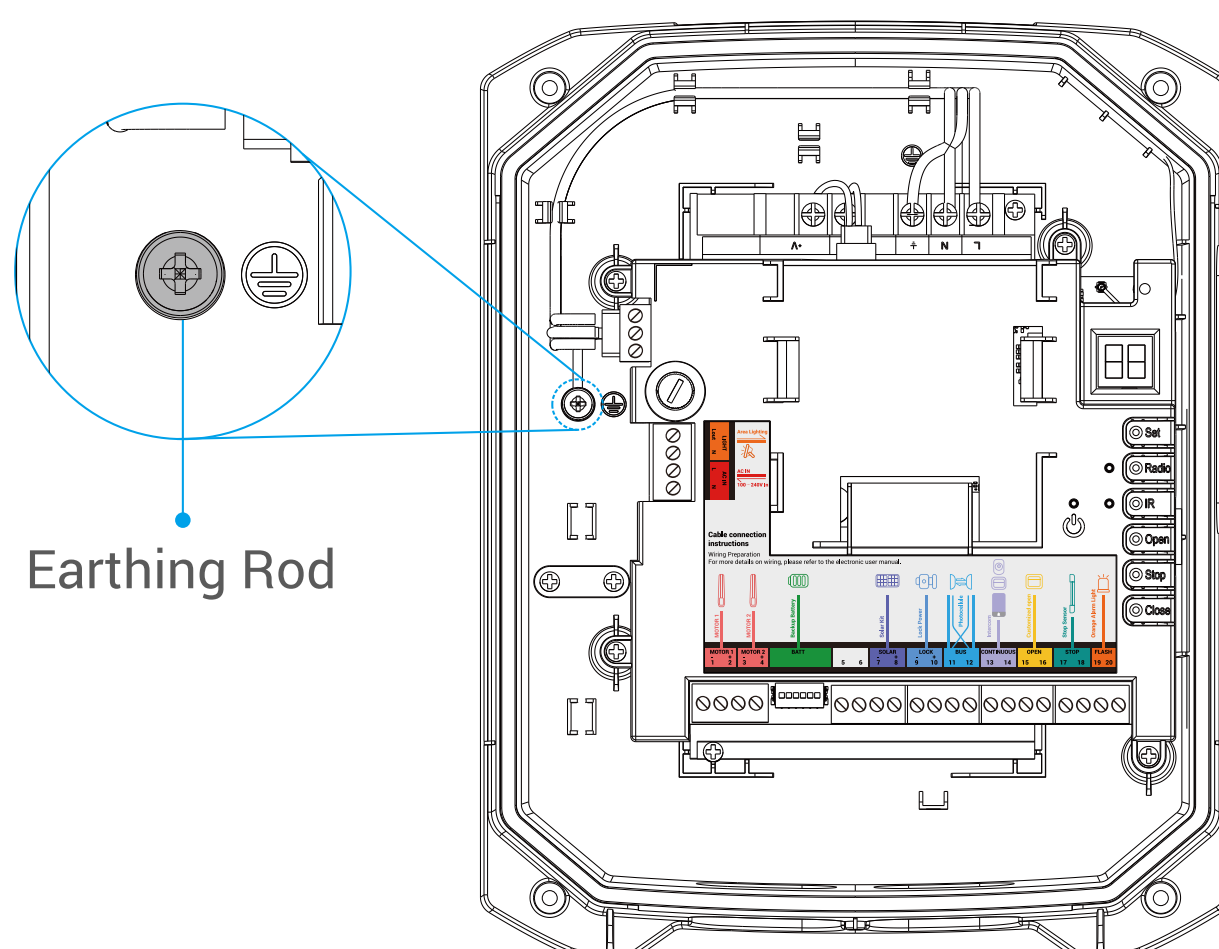

Prerequisites for Installation

1. Risk Analysis

1.1 Regulations

Installation of a motorized gate or a motor drive on an existing gate within the framework of "Residential" type use must be compliant with Regulation (EU) 305/2011 concerning building products.

The reference standard used to check this compliance is EN 13241-1 which refers to EN 12453, which specifies the motorized gate safety methods and components to reduce or completely eliminate hazards to people.

The installer must train the end user on the correct operation of the motorized gate, and the trained user must train the other people likely to use the motorized gate, using this guide.

It is specified in standard EN 12453 that the minimum protection of the gate's primary edge depends on the type of use and the type of control used to set the gate in motion.

The gate motor drive is a press control system, i.e. simply pressing one of the control parts (remote control, key selector, etc.) sets the gate in motion.

This gate motor drive is equipped with a force limiter which complies with appendix A of EN 12453 standard, within the framework of use with a gate that is compliant with the specifications given in this chapter.

The specifications of EN 12453 standard therefore enable the 3 following use cases, as well as the minimum levels of protection:

- Press activation with visible gate

Minimum level of protection: Force limiter only.

- Press activation with non-visible gate

Minimum level of protection: Force limiter and 2 pairs of photocells to protect the gate's opening and closing.

- Automatic control (automatic closure)

Minimum level of protection: Force limiter and 1 pair of photocells to protect the gate's automatic closing.

The flashing light is an essential safety component. The photocell type safety devices and their correct operation must be checked every six months.

1.2 Specifications of the Gate Opener

This motor drive can automate openwork swing gates up to 3 m wide and weighing up to 300 kg.

These maximum dimensions and weights are for an openwork-type gate and for use in an area that is not very windy. For use in an area with significant wind speed, it is necessary to reduce the maximum values indicated above for the gate to be motorized.

1.3 Security Check on the Gate

The motorized gate is strictly for residential use. The gate must not be installed in an explosive or corrosive atmosphere (presence of gas, flammable smoke, vapour or dust).

The gate must not have locking systems (latch, lock, bolt, etc.).

The hinges of the gate must be on the same axis and the axis must be vertical. The pillars supporting the gate must be strong and stable enough so that they do

not bend (or break) under the weight of the gate. Without the motor drive, the gate must be in good mechanical conditions, correctly balanced and open and close without friction or resistance. Greasing the hinges is recommended. Check that the fastening points of the different components are in locations that are sheltered from shock and that the surfaces are solid enough. Check that the gate does not have any part protruding from its structure. The central stop and side stops must be appropriately fastened so as not to give way under the force exerted by the motorized gate.

If installation does not correspond to one of the cases shown in the guide, contact us so that we can provide all the components necessary for proper installation with no risk of damage. The motor drive cannot be used with a driven part that has a door.

1.4 Safety Rules

The actual opening of a gate may create dangerous situations for people, goods and vehicles in the vicinity that by nature, cannot always be avoided by design.

The possible hazards depend on the state of the gate, the manner in which it is used and the installation site.

After having checked that the gate to be motorized complies with the requirements given in this chapter and before beginning the installation, a hazard analysis of the installation must be conducted in order to eliminate all dangerous situations or to indicate them if they cannot be eliminated.

2. Risk Elimination

The risks generated by a motorized 2-leaf gate as well as the solutions adapted to eliminate them are:

2.1 At Secondary Edges

Depending on the installation, there may be a shear zone between the leaf and the corner of the pillar.

In this case, it is recommended to remove this area, leaving a useful distance of at least 15mm, either by positioning the side stops properly, or by notching the corner of the pillars without weakening them, or both if necessary.

If this is not possible, the risk must be signaled visually.

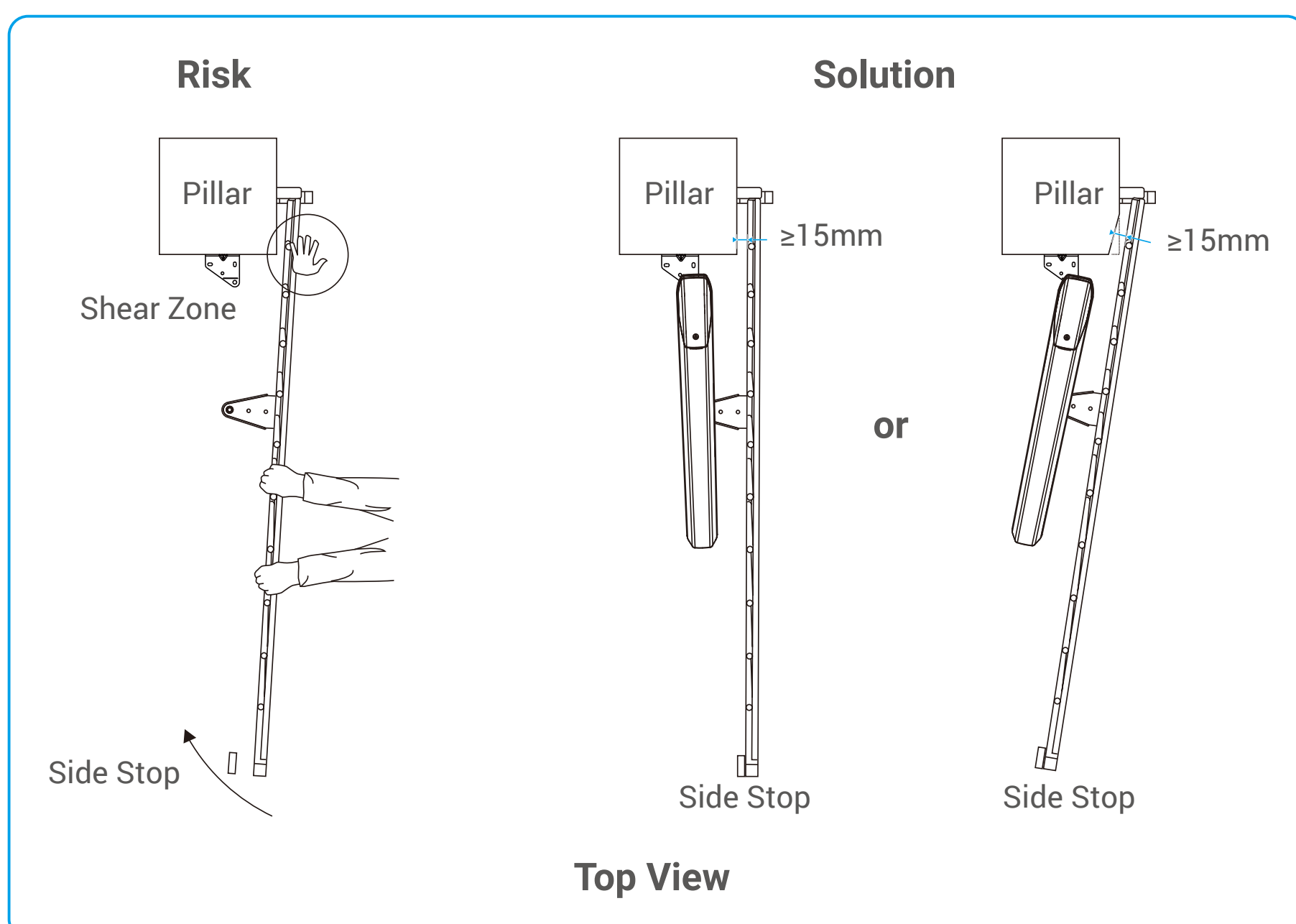

2.2 At Lower Edges

Depending on the installation, a toe hazard zone may exist between the gate's bottom edge and the floor, as shown in the figure.

To eliminate this hazard, maintain a minimum safe distance of 50 mm or a maximum gap of 5 mm between the gate and the floor.

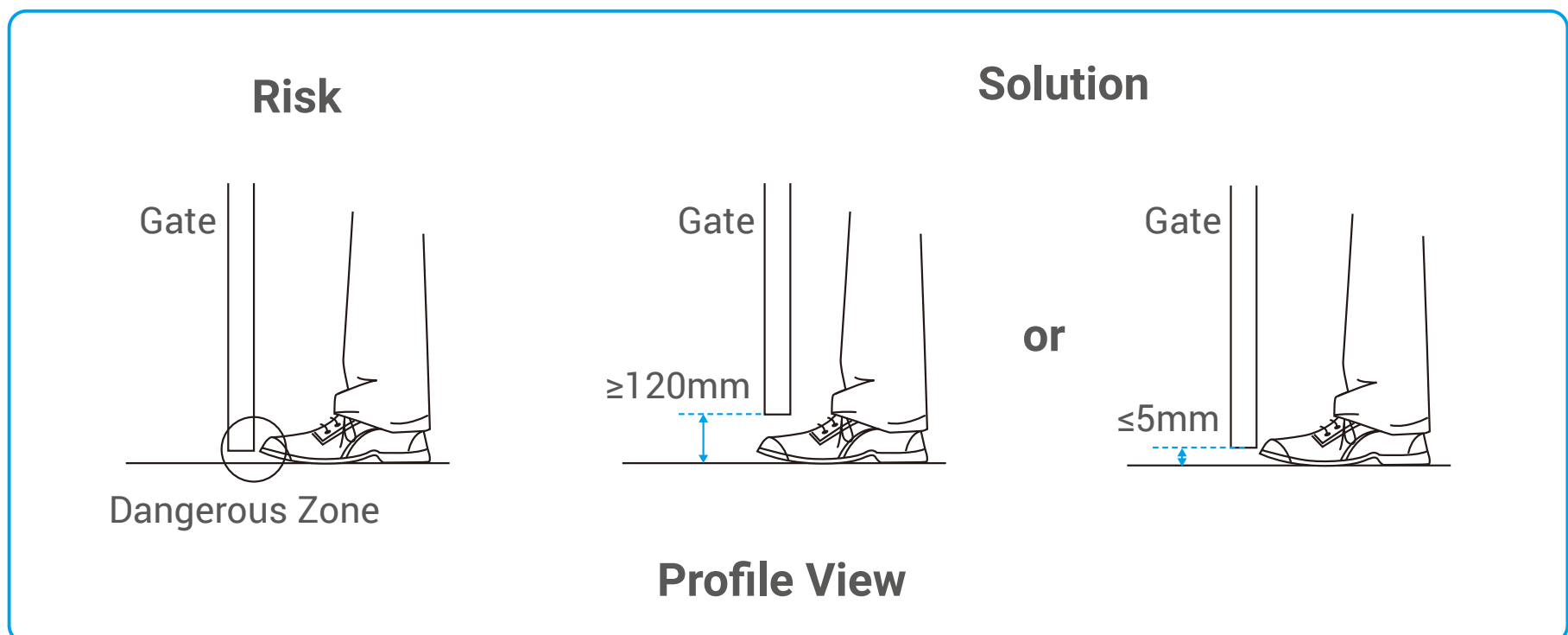

2.3 Between Leaves and Fixed Parts Located Nearby

Depending on the configuration of the site where the motorized gate is located, there may be areas of confinement between the leaves in the open position and fixed parts located nearby. In order to eliminate these zones, it is mandatory to leave a minimum safety distance of 500mm between the fixed part located nearby and the moving parts of the motorized gate.

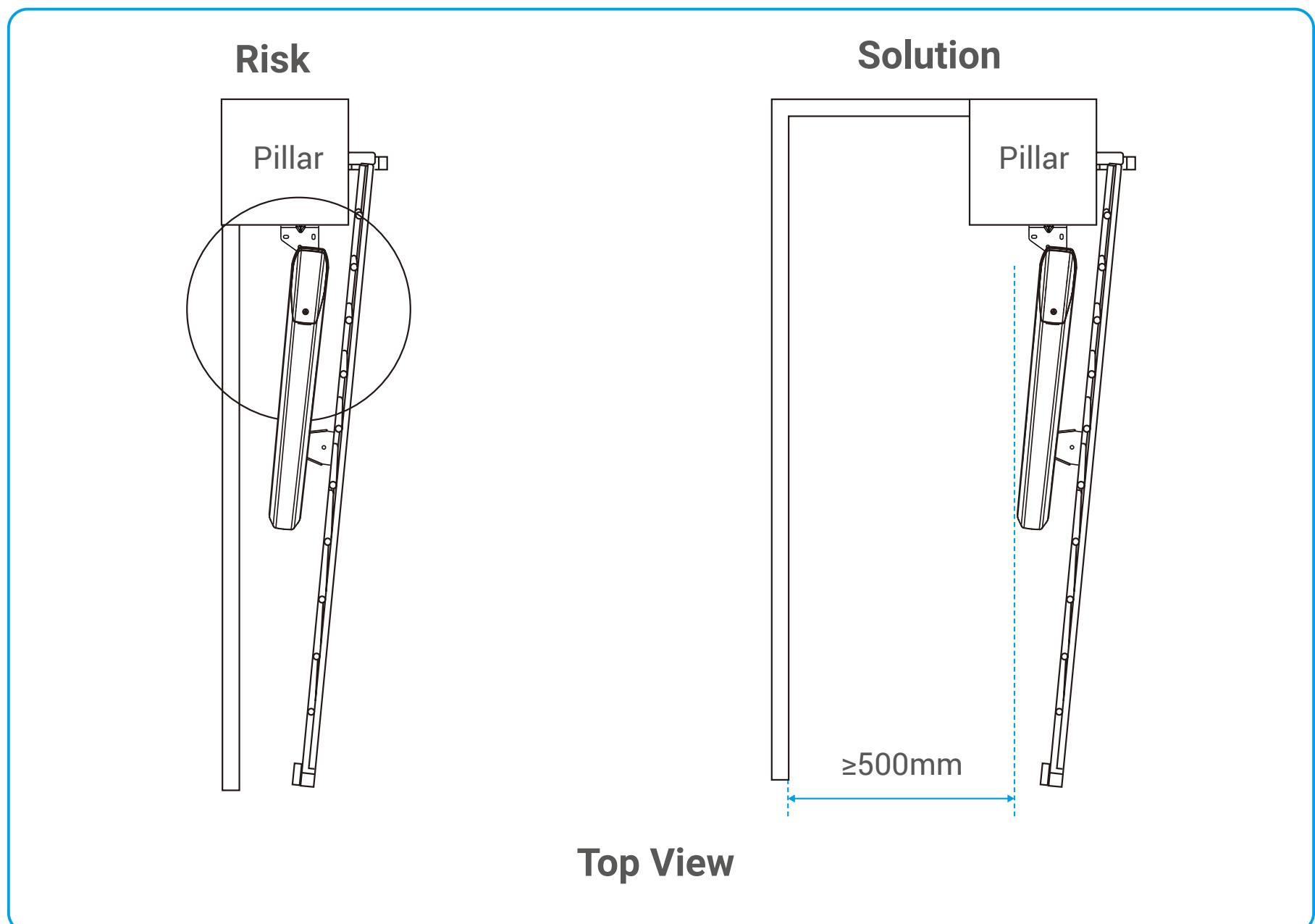

2.4 Prevention of Other Risks

The operating member of a non-locking switch must be located in direct view of the driven part but away from the moving parts. Unless operated with a key, it must be installed at a minimum height of 1.5m and not accessible to the public.





After installation, ensure that the parts of the gate do not extend above a sidewalk or roadway accessible to the public.

Install the Wireless Repeater

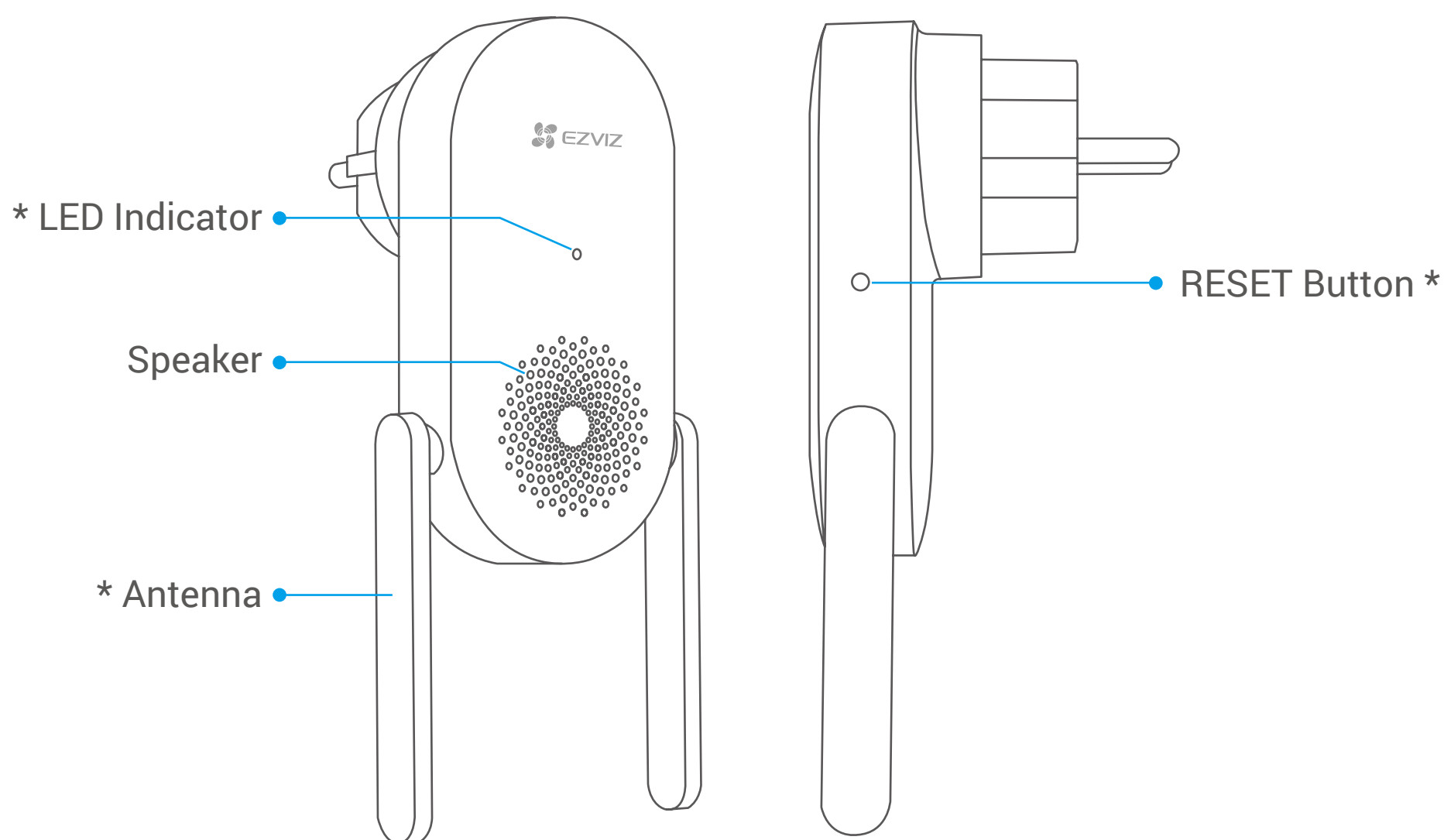
i For installation and use instructions of the wireless repeater, please refer to its user manual.

1. Basics



Name	Description
Antenna	Enhances the transmission of the wireless network signals between the wireless repeater and gate opener and alarm light camera.
LED Indicator	 Solid red: Wireless repeater is starting up.
	 Slow-flashing red: Wi-Fi connection has failed.
	 Fast-flashing red: The wireless repeater's connection to the gate opener or the alarm light camera is broken.
	 Solid blue: Wireless repeater is functioning properly.
RESET Button	 Fast-flashing blue: Wireless repeater is ready for Wi-Fi connection.
	<p>Reset the wireless repeater:</p> <p>i This operation is necessary when you need to change the wireless repeater's network, such as after relocating the gate opener.</p> <p>Press and hold this button for at least 3 seconds (but less than 10 seconds) until you hear a beep sound, then release the button. The LED indicator will become solid red, which indicates that the wireless repeater has been restarted and all parameters have been reset to defaults.</p>
	<p>Re-bind the wireless repeater:</p> <p>i This operation is only necessary when setting up a newly purchased wireless repeater after your original one becomes unusable.</p> <p>Press and hold this button for 10 seconds until the LED indicator becomes fast-flashing red and blue alternately, which indicates that the wireless repeater is now ready for re-binding.</p>
Power Input	<p>Quick mute:</p> <p>Press the button once to mute the wireless repeater.</p> <p>100 to 240 VAC, 50/60Hz</p>

2. Get the EZVIZ App

- i** Before downloading the app:
 - If the app is already installed, verify that it is the latest version by checking for updates in your app store.
 - If the app is not installed, follow the steps below to download it.

1. Connect your mobile phone to Wi-Fi (suggested).
2. Download the EZVIZ app by searching "EZVIZ" in the App Store or Google Play™.
3. Register an EZVIZ account and log in to the app.

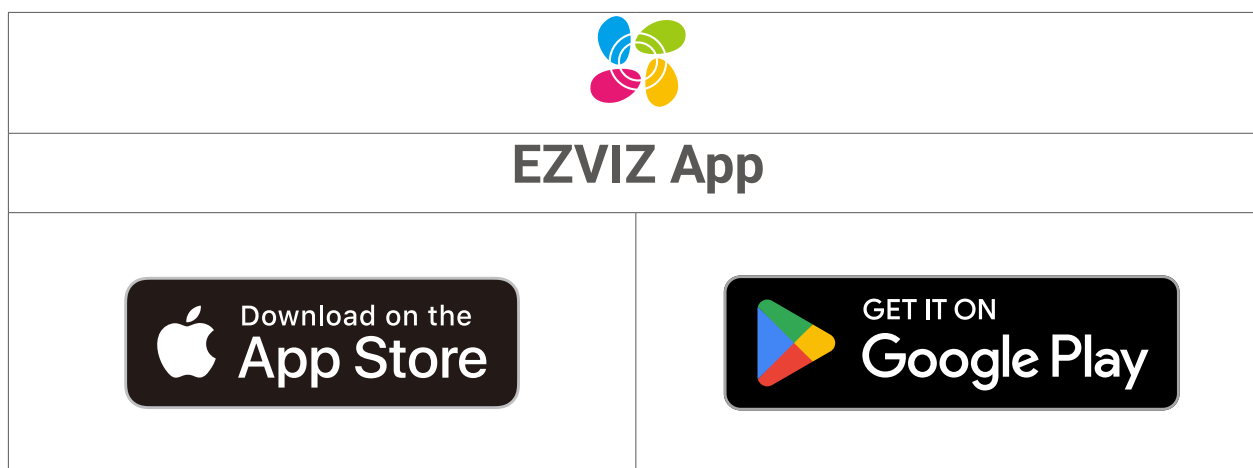

3. Choose an Installation Location

Choose an installation location with a good wireless signal to wireless repeater. Please keep the following tips in mind:

- Install the wireless repeater as close to the gate opener and the alarm light camera as possible, with as few walls in between as possible.
- The antennas of the wireless repeater should be pulled up.
- Make sure that there are no metal obstructions nearby.

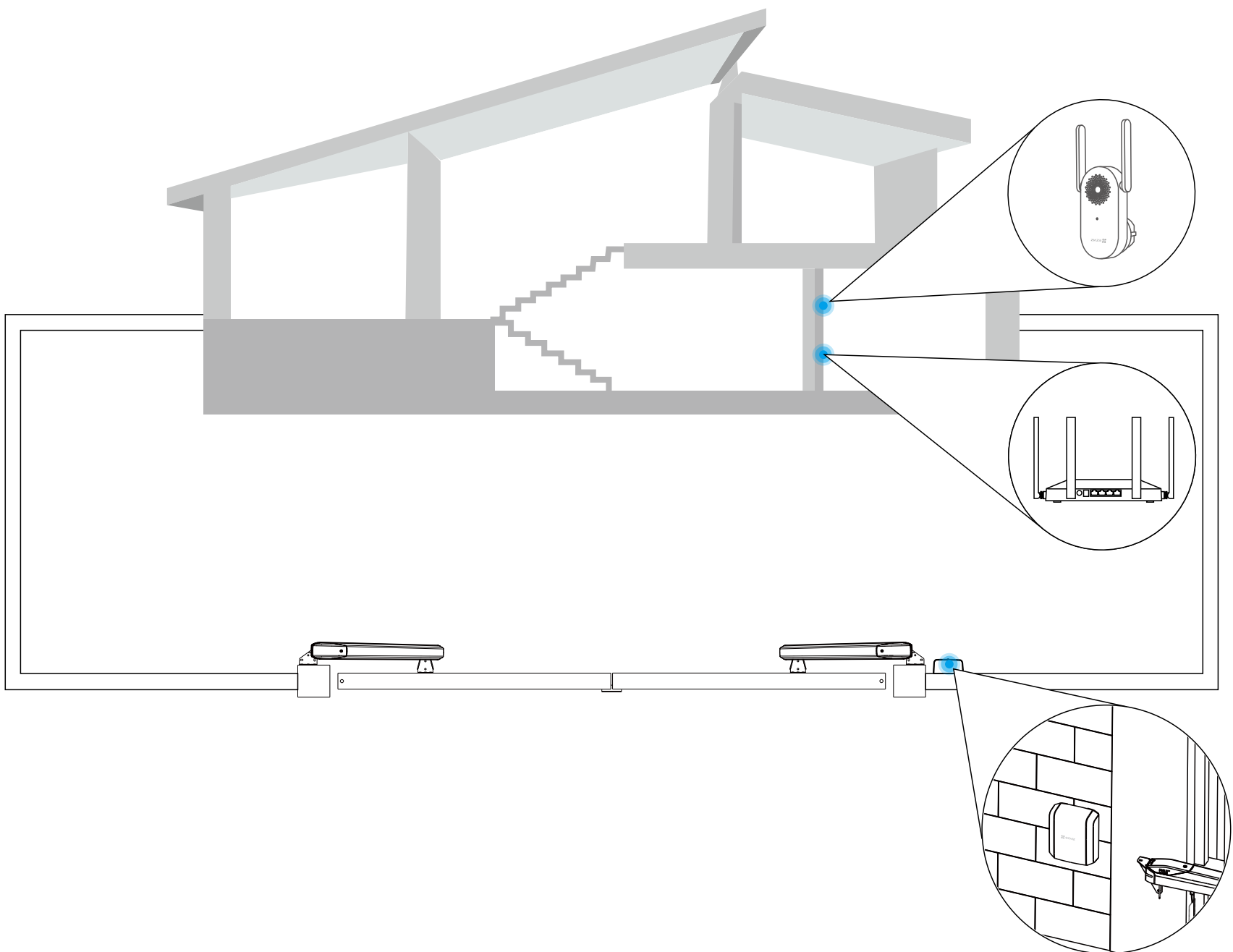

Wireless Communication Topology

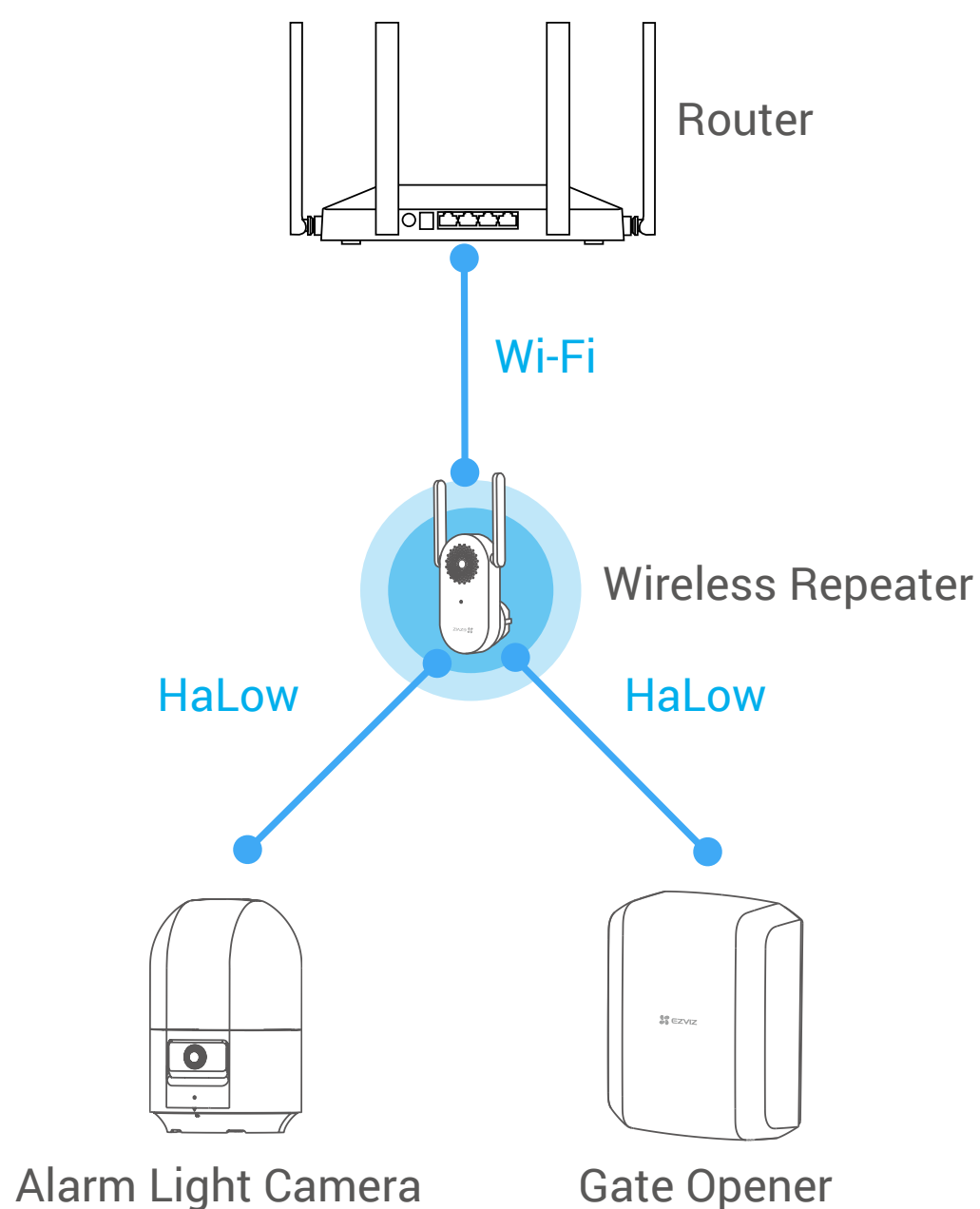

- i** Data communication between the wireless repeater and the alarm light camera and the gate opener is based on private protocols, independent of your Wi-Fi network.

Transmission Performance of Wireless Repeater

Environment	Distance *
In open environment	300 m
With 1 wall in between	110 m
With 2 walls in between	75 m
With 3 walls in between	65 m

* Data communication between the wireless repeater and the alarm light camera, as well as the gate opener, is based on private protocols, independent of your Wi-Fi network.

4. Plug in Wireless Repeater

Plug the wireless repeater into a power outlet. When the LED indicator becomes fast-flashing blue, it indicates that the wireless repeater is ready for Wi-Fi connection.

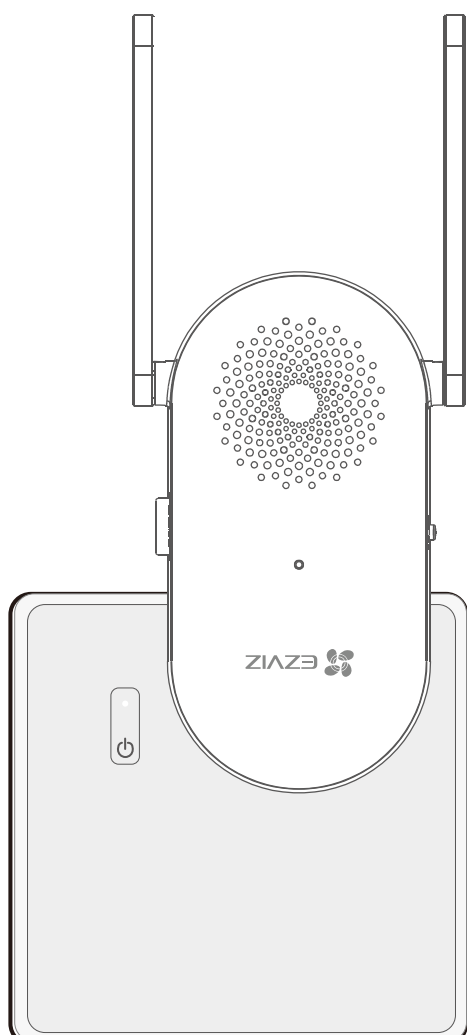

5. Add Wireless Repeater to Your EZVIZ Account

1. Log in to your EZVIZ account.
2. On the Home screen, tap "+" in the upper-right corner to go to the Scan QR Code page.
3. Scan the QR code on the body of the wireless repeater.

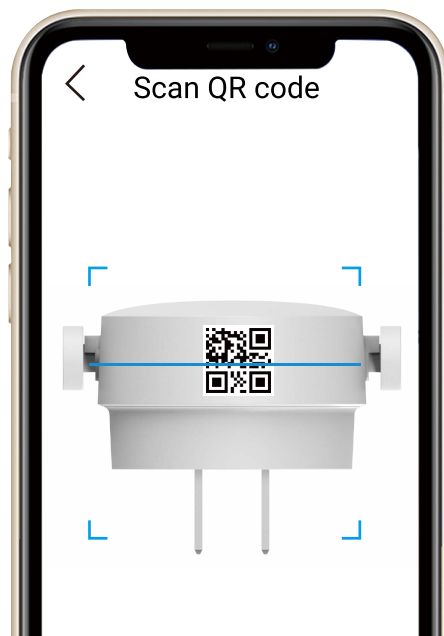

4. Follow the EZVIZ app wizard to finish Wi-Fi configuration and add the wireless repeater to your EZVIZ account.
5. After the wireless repeater is added, complete Terminal Authorization in the EZVIZ app so that the gate opener and the alarm light camera will be automatically added to your EZVIZ account after you power on the gate opener later.

i If terminal authorization is not completed, the gate opener and alarm light camera will not be added after power-on.

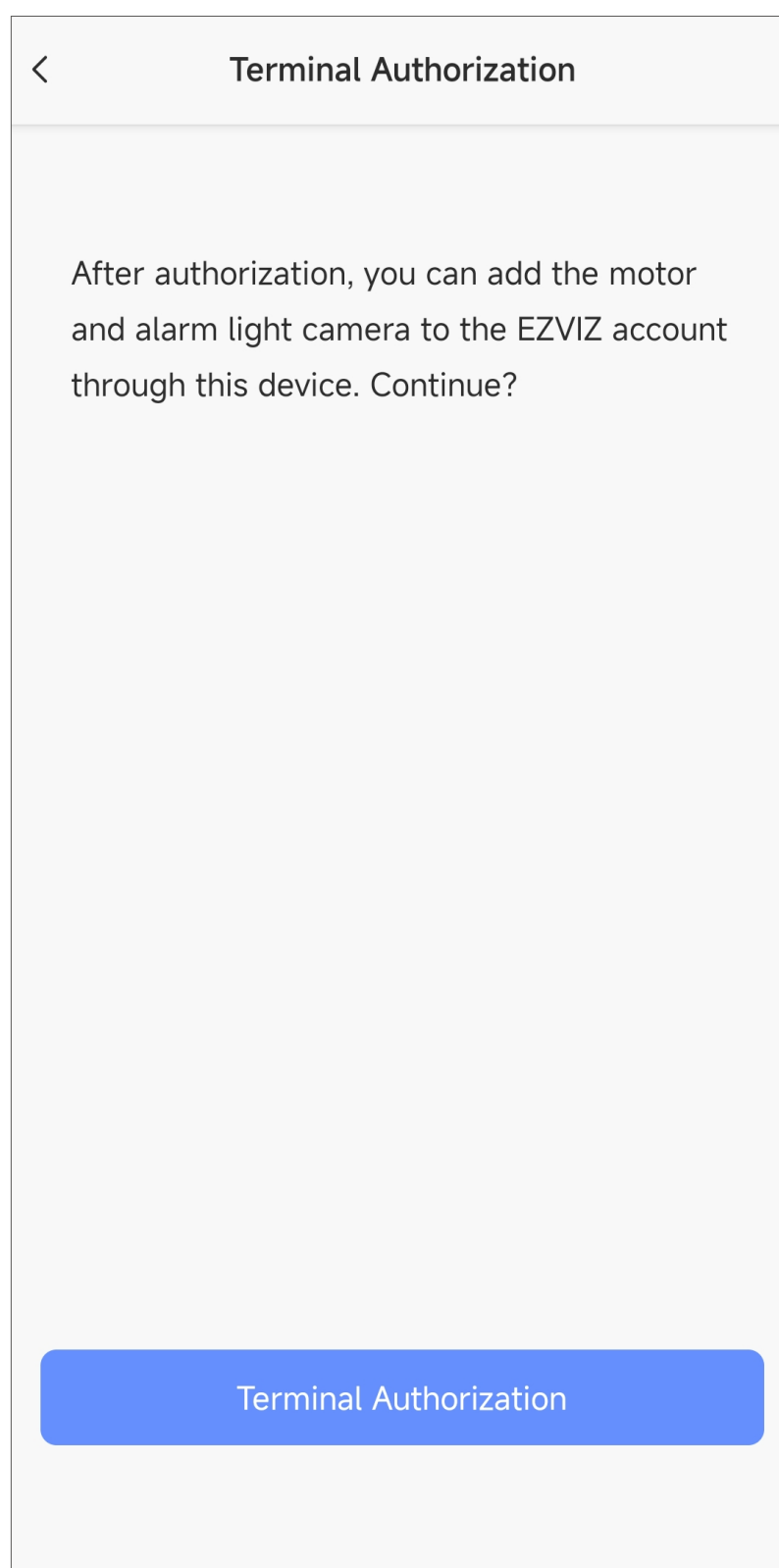

- Please connect your wireless repeater to the Wi-Fi network to which your mobile phone has been connected.
- If the wireless repeater fails to connect your Wi-Fi network, press and hold the RESET button for about 5s to restart the wireless repeater and repeat the steps above.
- If you want to connect the wireless repeater to another Wi-Fi network, go to Settings > Network Settings in the EZVIZ app to change the Wi-Fi network.

6. Add Gate Opener to Your EZVIZ Account

After completing terminal authorization, the QR Code Scanning page appears, reminding you to scan the code on the control unit.

1. Tap "Next".
2. Scan the QR code (with the "Device Information" title above) on the control unit.

- **DO NOT** scan the QR code on the wireless repeater that you just scanned.
- **DO NOT** scan the installation videos QR code (with the "Installation Videos" title above the code).

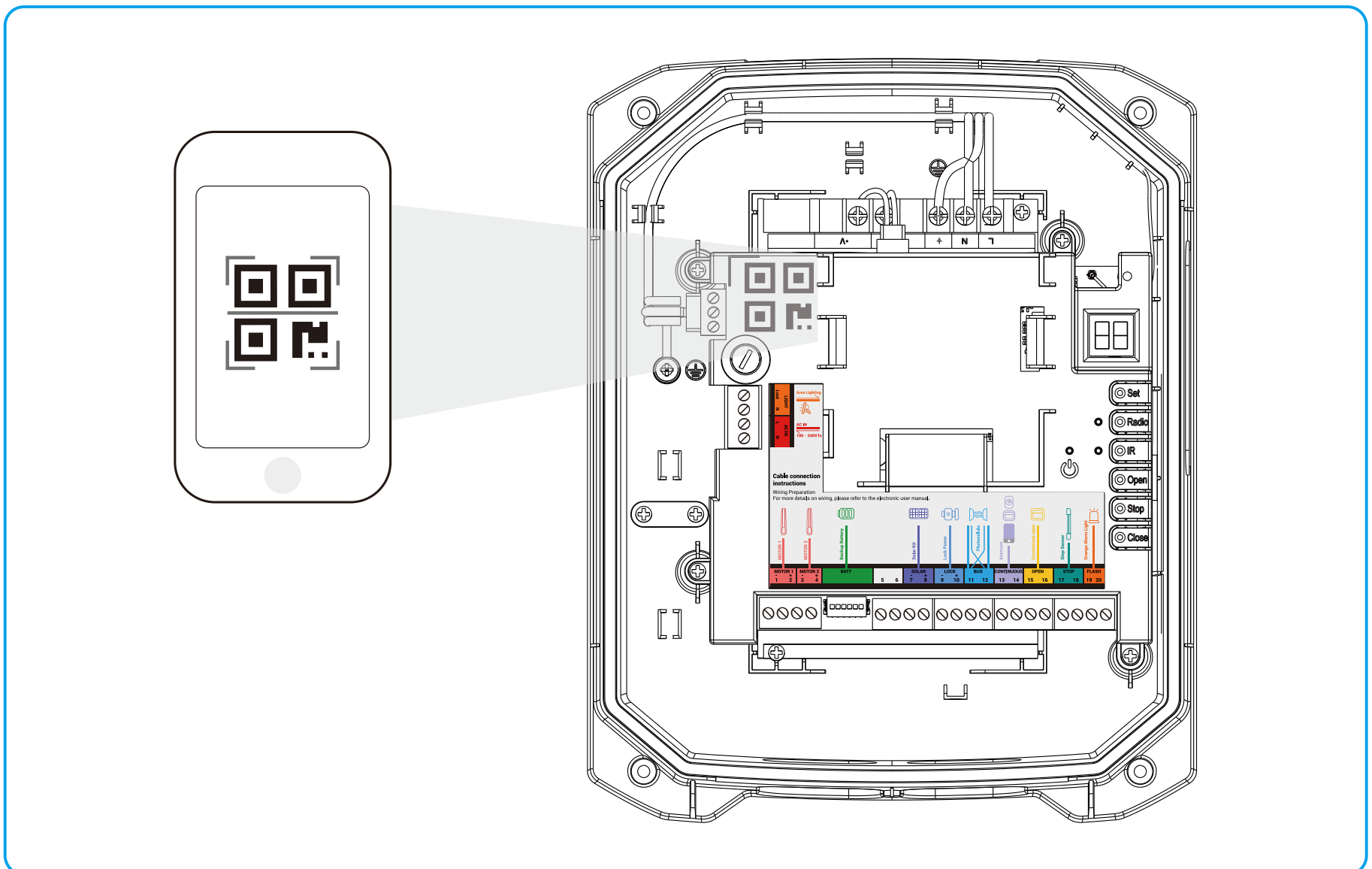

After successful code scanning, the installation wizard appears. You can follow the installation wizard to start installing the gate opener.

If the live view of the alarm light camera is freezing during normal use, check the network connection between the camera and the wireless repeater. As shown in the image below, in the EZVIZ app, go to the Settings page of the alarm light camera, select "Network Settings" and enable the "Wireless Test Mode". This mode will significantly improve the wireless performance for testing.

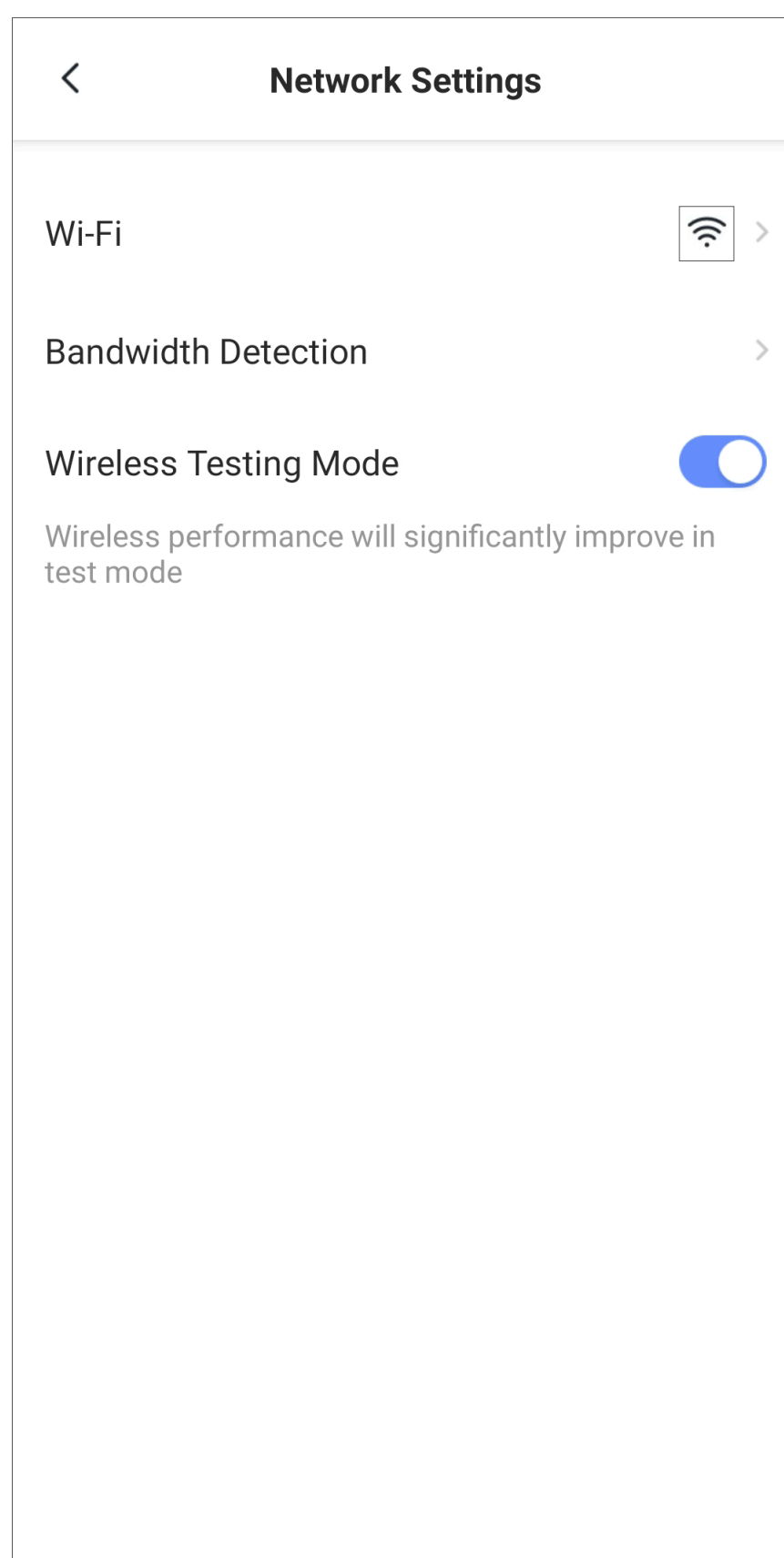

Install Cylinder and Control Unit

1. Basics

Control Unit

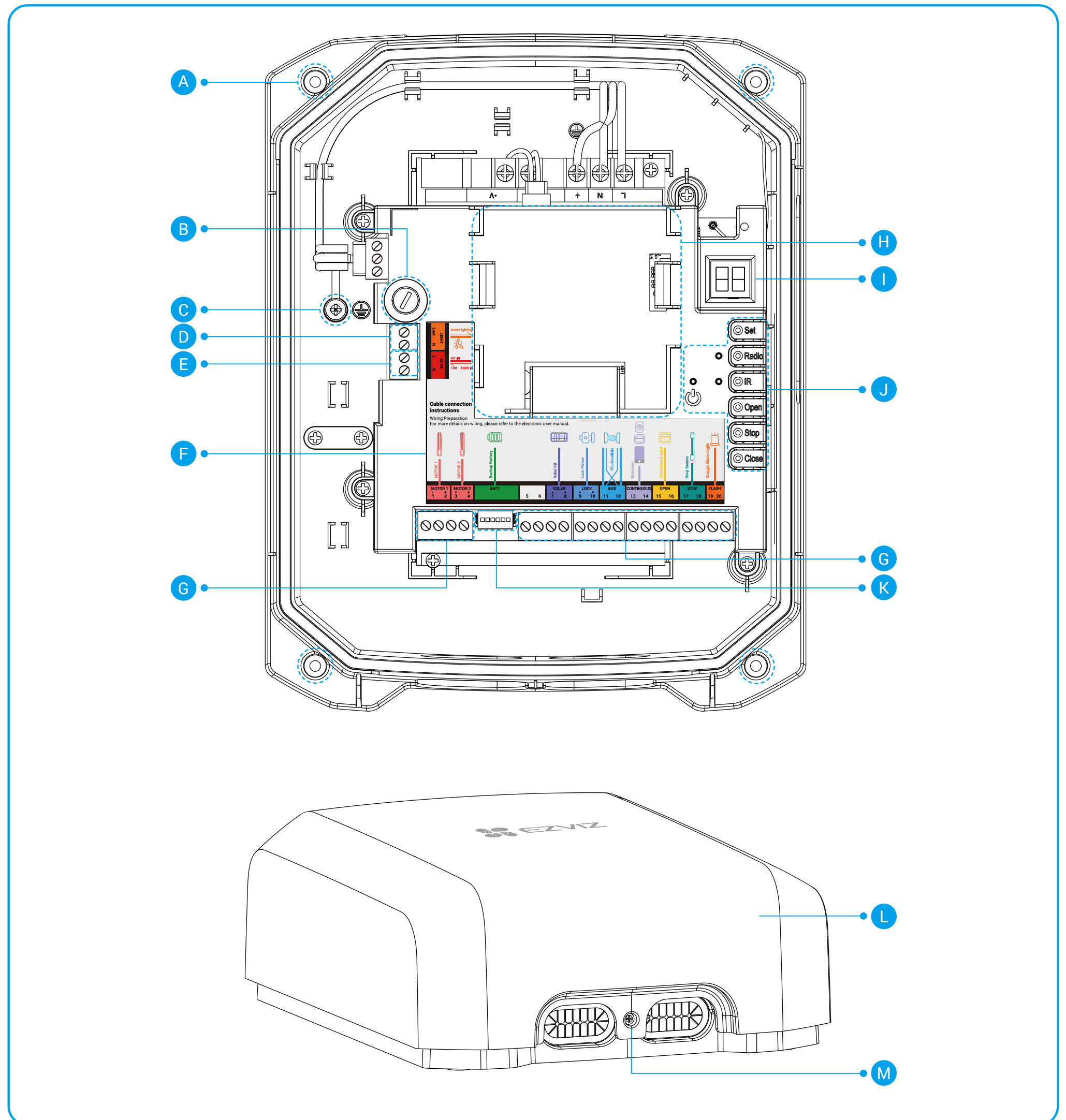

No.	Description	No.	Description
A	Mounting Hole ×4	H	Backup Battery Chamber
B	Fuse Holder *	I	Digital Display
C	Earthing Rod	J	Control Buttons and Indicators
D	Area Lighting Interfaces	K	Battery Terminal
E	Power Supply Interfaces	L	Cover
F	"Cable connection instructions" Label	M	Screw Hole
G	Terminal Blocks		





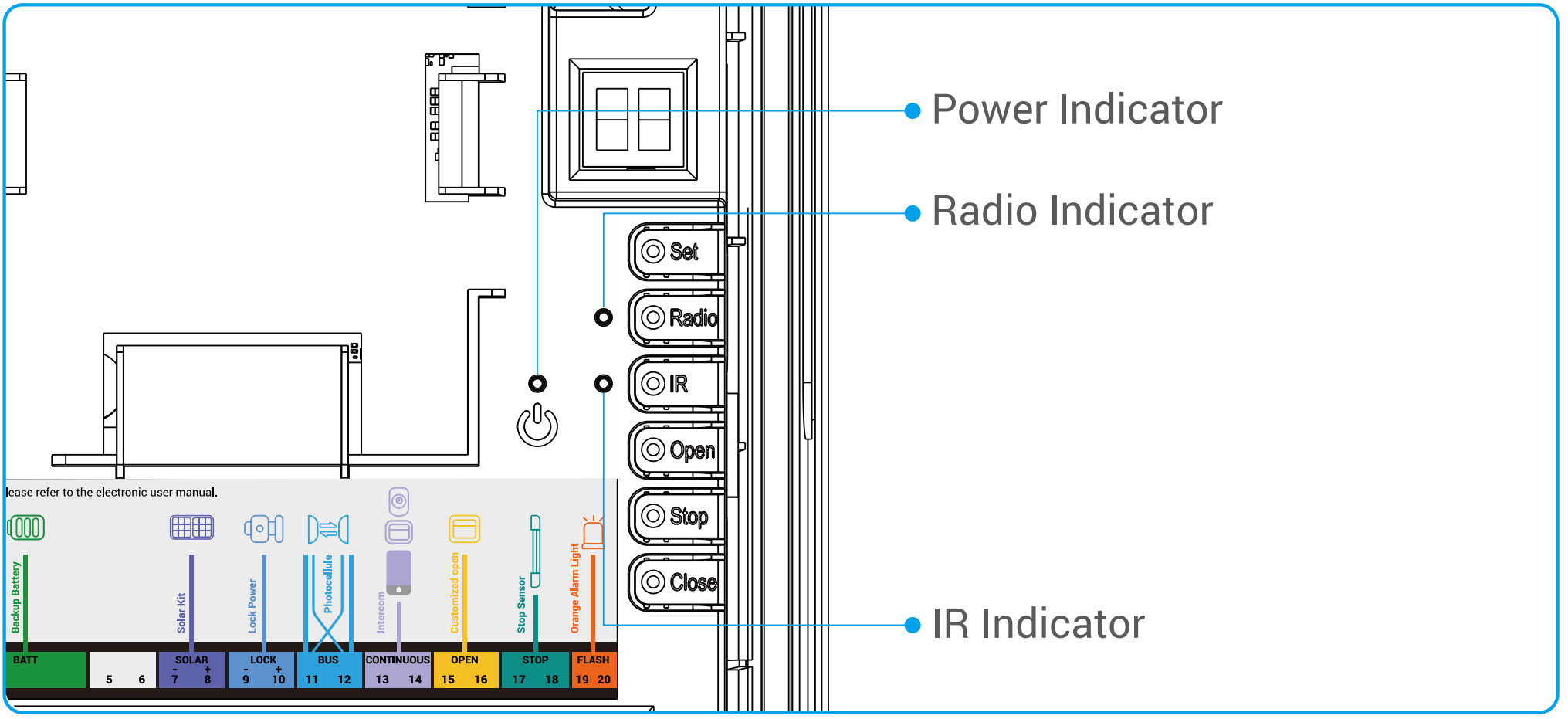

* Fuse specifications: $\Phi 5.2 \times 20\text{mm}$ 250VAC 5A

Presentation of Control Buttons and Indicators



Name	Description		
Set Button	Press and hold for 3 seconds	Enter or exit the main menu.	
	Press once	In the submenu mode, press once to exit the submenu and go back to the main menu.	
	Press and hold for 8 seconds	Restore the gate opener to factory settings.	
Radio Button	Press once	Enter the remote controller pairing mode.	
	Press and hold for 5 seconds	Clear all information about paired remote controllers.	
IR Button	Press once	Enter or exit the infrared self-testing mode.	
	Press and hold for 5 seconds	Start binding to a wireless repeater. i This operation is only necessary when setting up a newly purchased wireless repeater after your original one becomes unusable.	
Open Button	Press once	In normal working mode	Open the gate.
		In menu mode	Switch to the next option.
Stop Button	Press once	In normal working mode	Stop the gate.
		In menu mode	Confirm the current option.
	Press and hold for 5 seconds	Clear the current gate travel.	
Close Button	Press once	In normal working mode	Close the gate.
		In menu mode	Switch to the previous option.

LED Indicator	Description	
Radio Indicator		Solid red: The gate opener is now in remote controller pairing mode.
		Off: Exit pairing mode.
		Slow-flashing red (for 3 seconds): Remote controller paired successfully or the number of paired remote controllers has reached 8.
		Fast-flashing red (for 3 seconds): All remote controllers are cleared.

LED Indicator	Description
IR Indicator	In normal working mode:
	 Off: No obstacles are detected.
	 Solid red: Obstacles are detected.
	In infrared self-testing mode:
	 Solid red: No obstacles are detected.
 Slow-flashing red: Obstacles are detected.	
Power Indicator	 Solid red: The gate opener is powered by an AC 100-240V power supply or a DC 24V solar kit.
	 Off: The gate opener is powered by the backup battery.

Cylinder

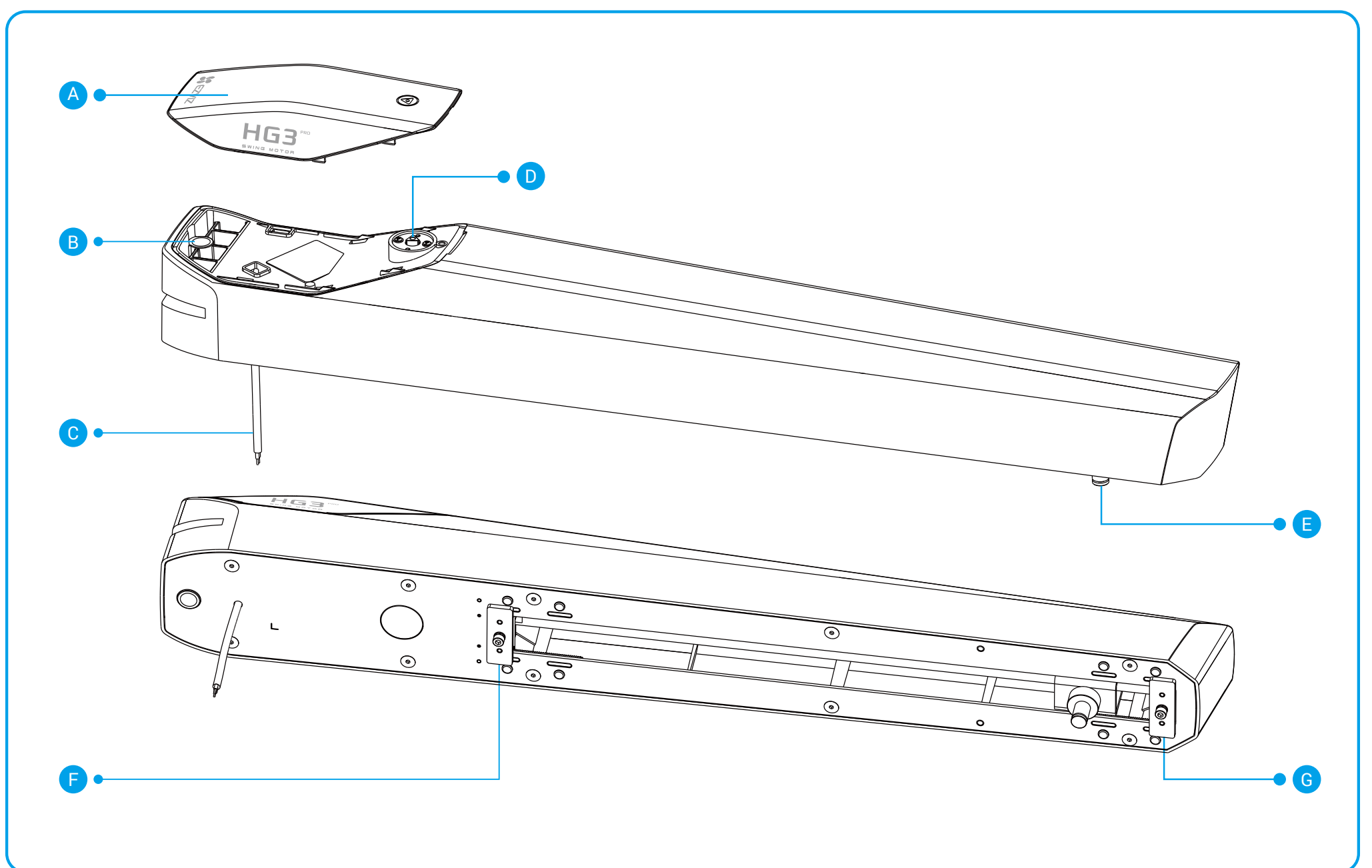

No.	Description	No.	Description
A	Cylinder Cover	E	Slider
B	Mounting Hole	F	Opening Stop Block
C	24V Power Cable	G	Closing Stop Block
D	Keyhole		

2. Preparation

- **Installation must be carried out by qualified personnel and respecting all the indications given in the "[Safety Regulations](#)" chapter.**
- **Before starting the installation, ensure that:**
 1. **Risks are reduced by following the recommendations in the "[Risk Analysis](#)" chapter.**
 2. **The desired usage has been correctly defined.**
 3. **The gate complies with the specifications given in the "[Technical Data](#)" chapter.**
- **The different stages of installation must be carried out in order and in accordance with the instructions given.**

2.1 Pre-installation Checks

Gate

Your gate is in good condition: it opens and closes normally with ease.

It remains horizontal throughout its travel. It opens inwards towards your property.

- Reinforcements

The cylinders must be secured to the horizontal reinforcements of the gate leaves, which should ideally be positioned 1/3 up the gate.

If there are no reinforcements, use metal reinforcement plates approximately 4 mm thick.

- Closing End Stops On The Ground

The gate's closing travel must be defined by end stops firmly fixed in the ground. The opening stops are integrated in the cylinders.

- Mechanical lock

If the gate is equipped with a mechanical lock, it must be removed.

Pillars

The pillars must have a robust structure and be at least 23 cm wide. If they do not, improvements may have to be made to your pillar to guarantee correct installation and to ensure that the bracket stays in place.

It is not recommended to mount the bracket level with the pillar: risk of spalling.

2.2 Determine Installation Positions

Before starting installation, determine appropriate installation positions for the pillar fixing brackets and the gate fixing brackets.

Follow the steps below.

1. Based on the dimension A, determine the dimension B in the table.

i If the dimension A does not have an exact match in the table, select the closest value.

2. Based on the dimension B, determine the dimension C in the table. Determine which side of the pillar fixing brackets to use for fixing based on dimension C.

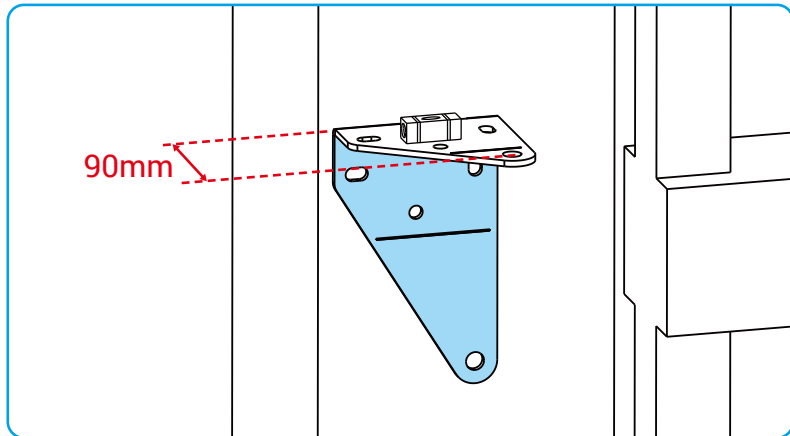

Dimension C=90mm
Use the long side for fixing

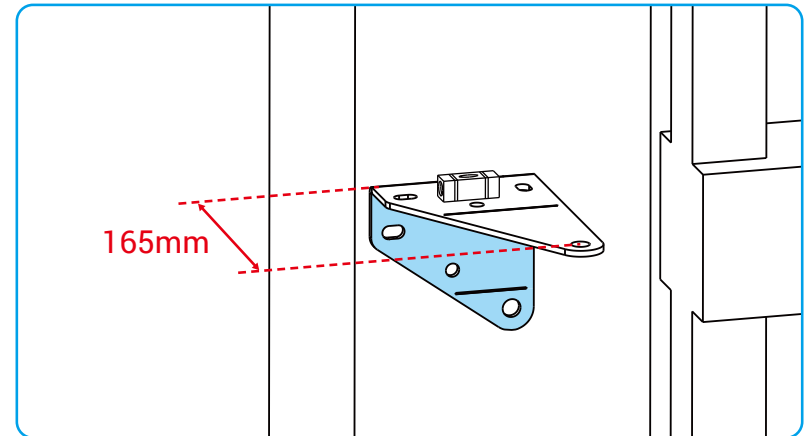

Dimension C=165mm
Use the short side for fixing

3. Determine the dimension D in the table based on the maximum gate opening angle α .

4. Determine the horizontal positions of pillar fixing bracket on the pillar and the gate fixing bracket on the crossbeam based on dimension B and D.

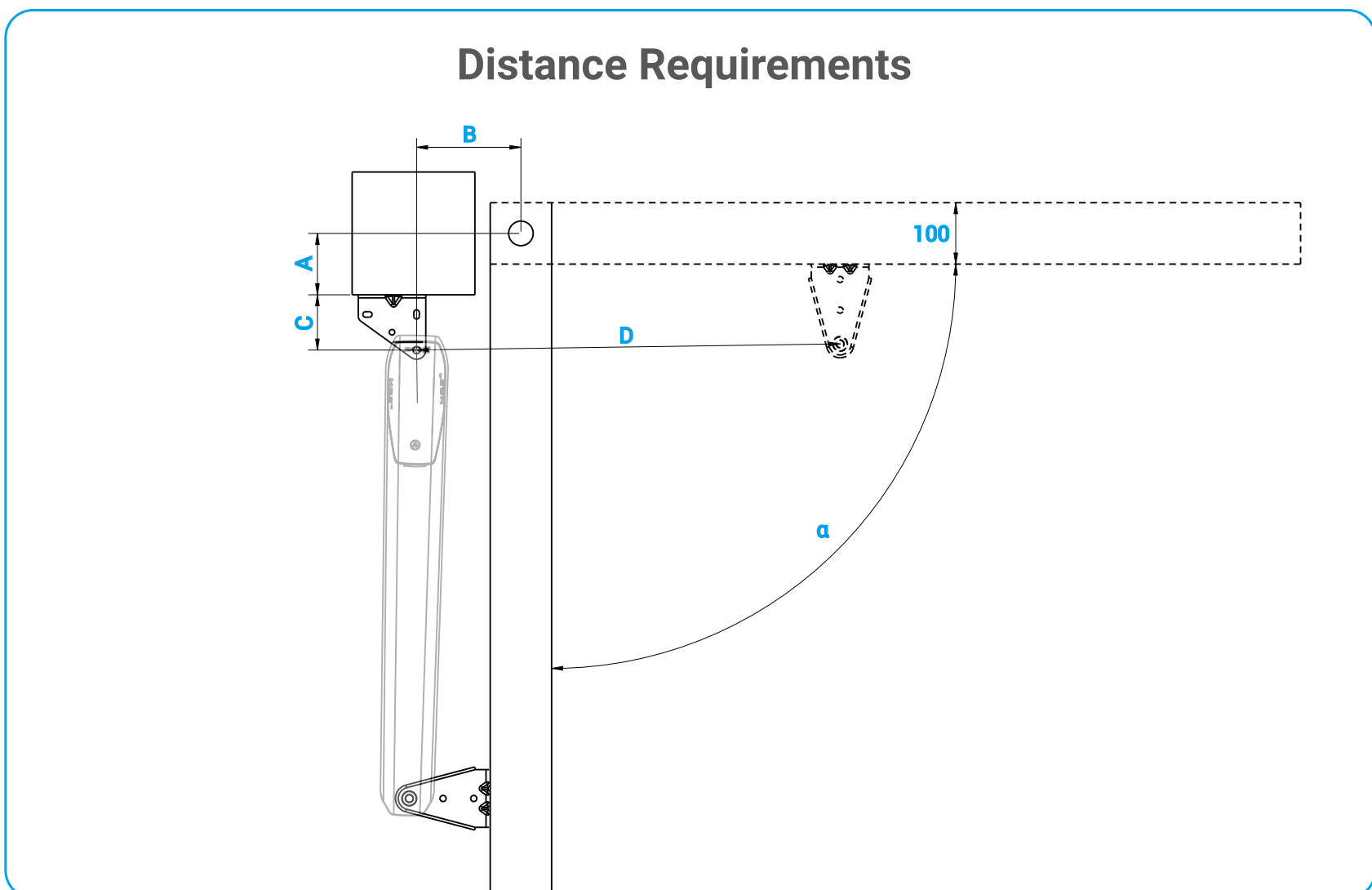

- Dimension A: the distance between the hinge and the installation surface.
- Dimension B: the distance between the hinge and the center of the pillar fixing bracket.
- Dimension C: the distance between the mounting hole center of the pillar fixing bracket and the installation surface.
- Dimension D: the distance between the mounting hole centers of the pillar fixing bracket and the gate fixing bracket.

Dimension A (mm)	Dimension B (mm)	Dimension C (mm)	Dimension D (mm)	Opening Angle α (°)
-30	205	165	710	115°
0	200			110°
10	195			100°
20	195	90	685	120°
30	185	165	710	105°
40	185			105°
50	175			100°
60	165			100°

Dimension A (mm)	Dimension B (mm)	Dimension C (mm)	Dimension D (mm)	Opening Angle α (°)
70	190	90	690	110°
80	185			105°
90	185			105°
100	170			100°
110	170			100°
120	160			100°
130	150		685	95°
140	140			90°
150	140			90°
160	130			90°
170	120			90°
180	110			90°
190	110			90°
200	110			90°

i The dimensions listed in the table are recommended typical values and can be scaled proportionally based on actual conditions. Dimension A is fixed; determine dimension B, C, D and α as needed.

3. Install Pillar and Gate Fixing Brackets

3.1 Mark the Installation Position

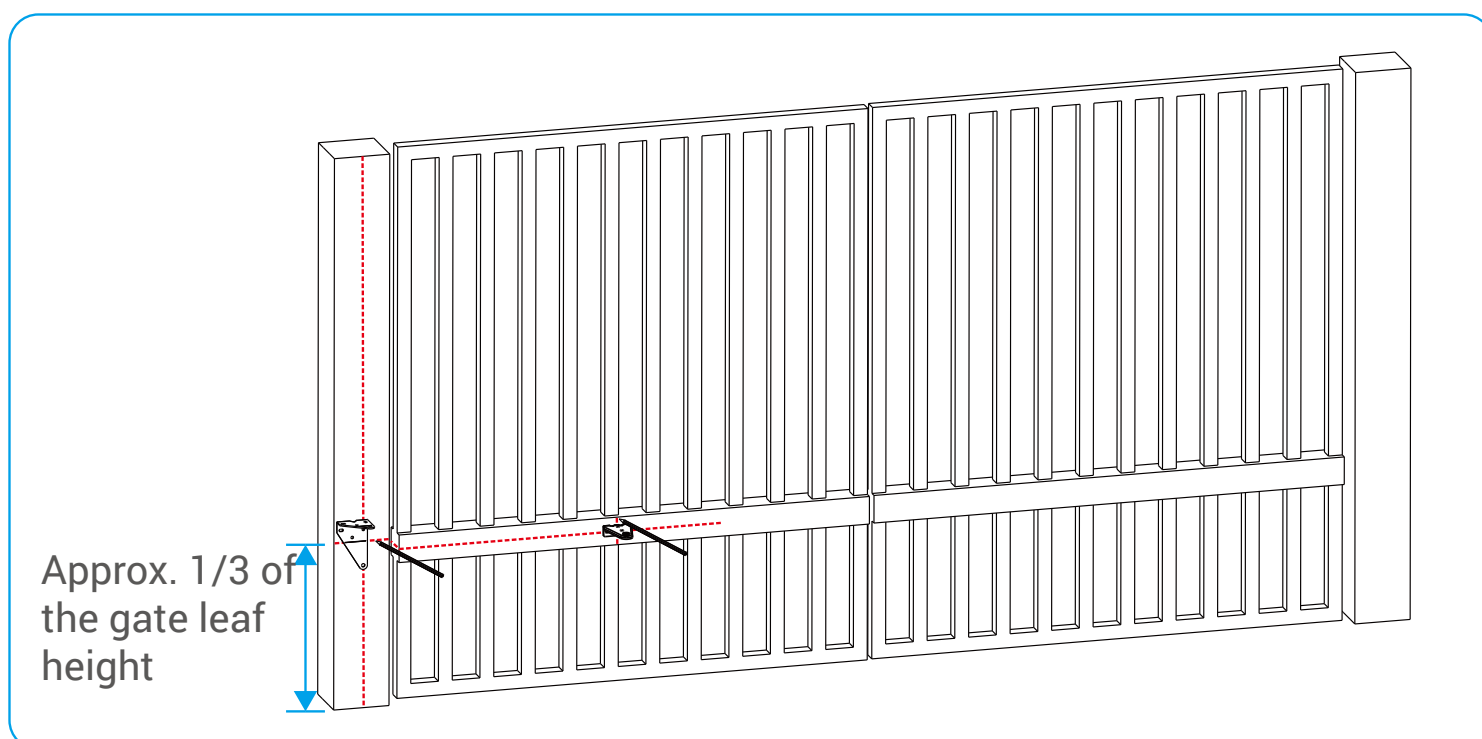

1. Based on the distance B, draw a vertical line on the pillar with a pencil.
2. **(Recommended)** Draw a horizontal line at the vertical center of the crossbeam.

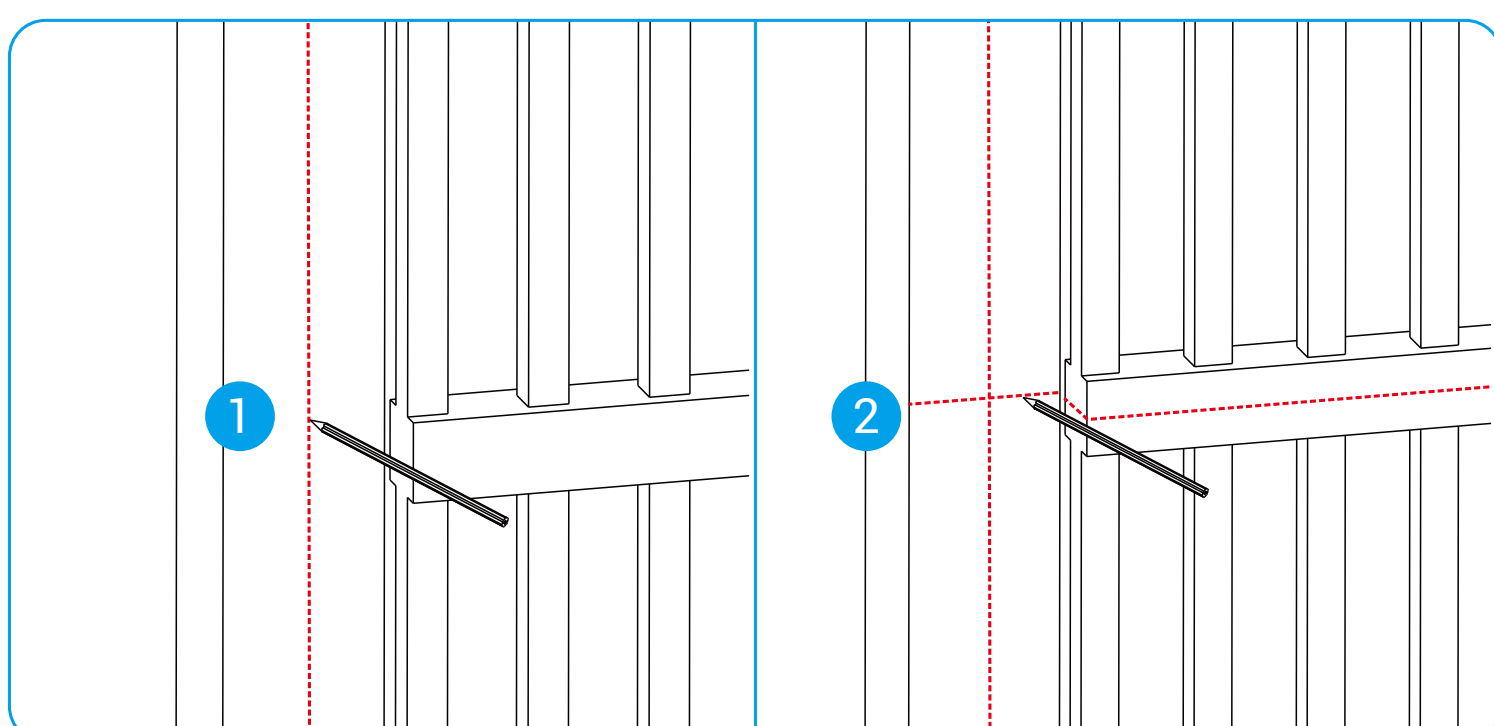

2. Align the horizontal marks on the pillar fixing bracket with the horizontal lines, and the mounting hole centers with the vertical lines to determine its installation position.

i Note: Position the bracket with its long side or short side based on dimension C.

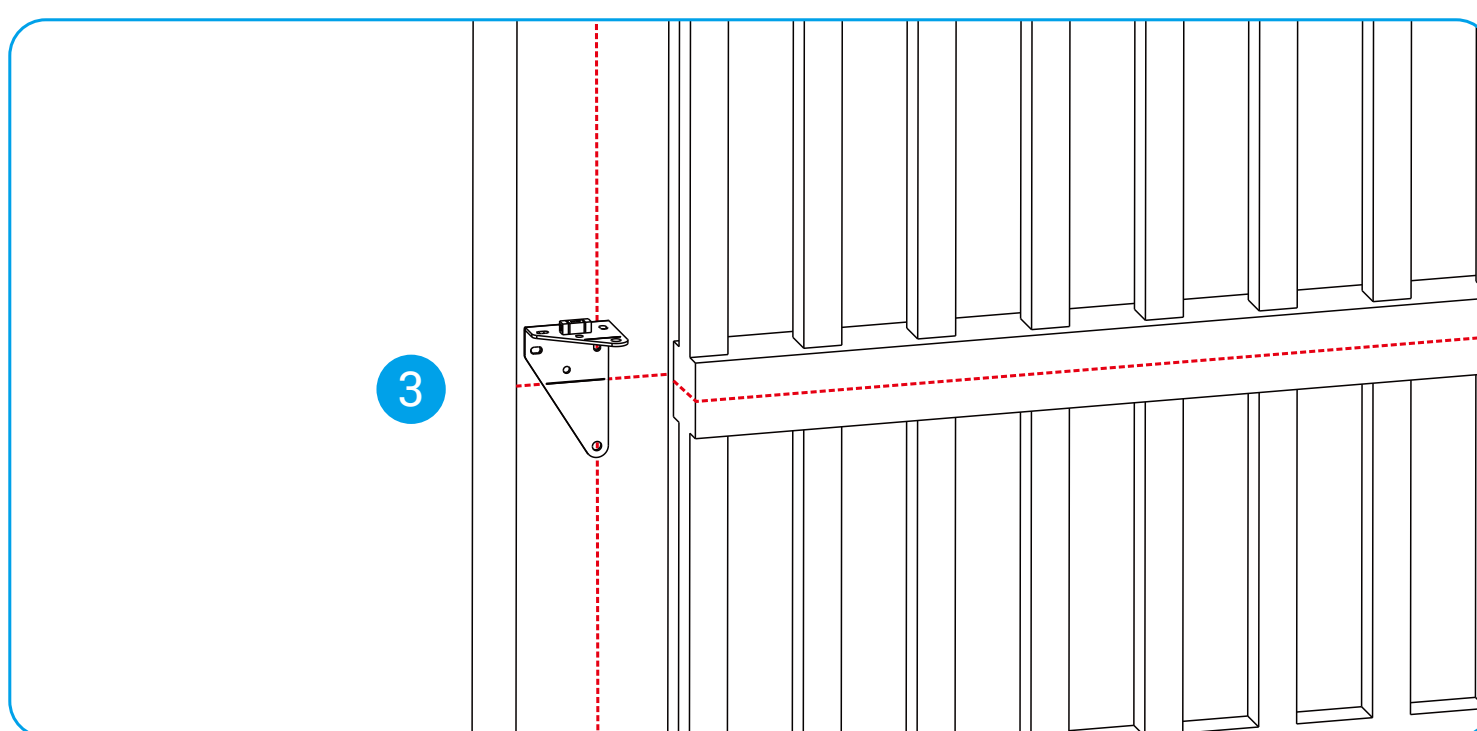

3. Based on the distance D, draw a vertical line on the crossbeam. Align the mounting hole center of the gate fixing bracket with the intersection of the horizontal and vertical lines to determine its installation position.

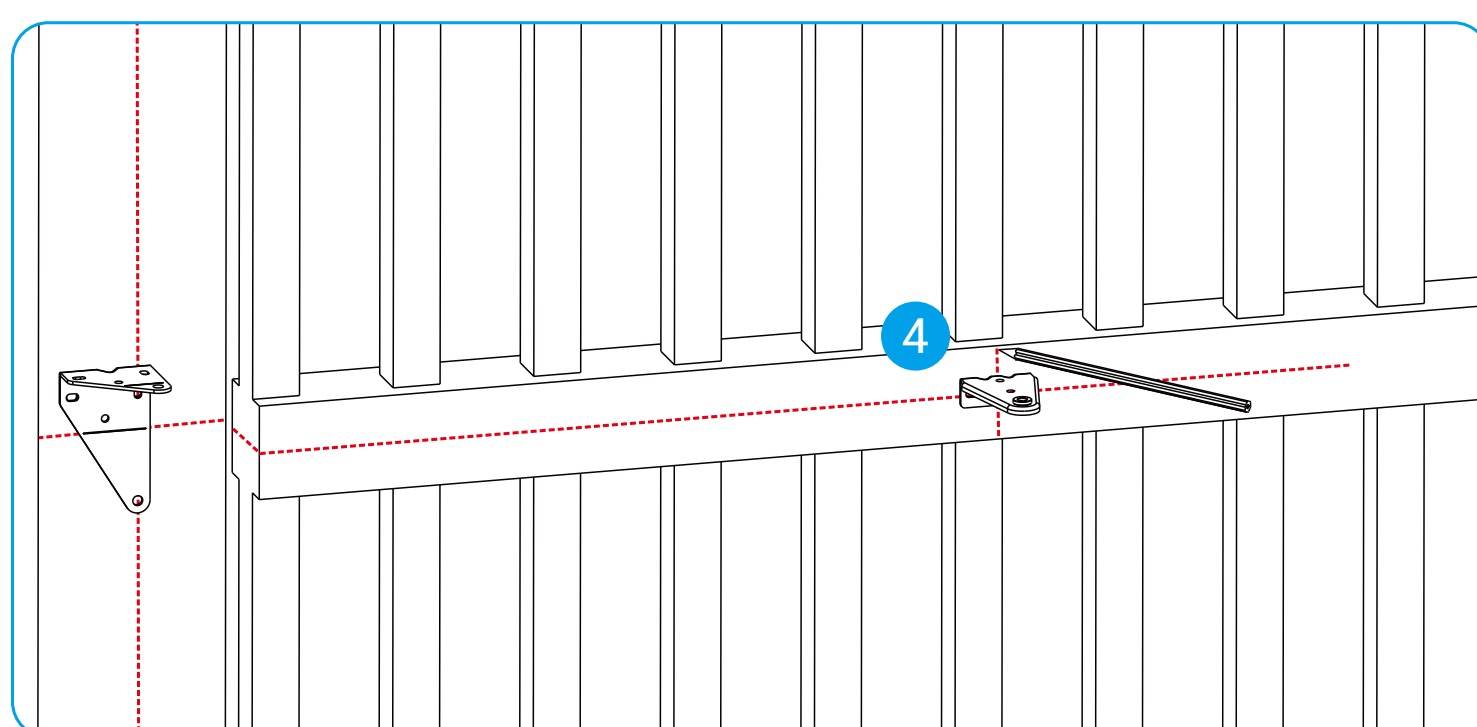

3.2 Fixing the Brackets

i When drilling holes, use the mini level (purchase separately) to ensure the holes are strictly aligned in the horizontal direction.

1. Check that the pillar fixing bracket is horizontal, and mark the mounting holes for the bracket. Then drill 3 holes in pillar in the locations marked.

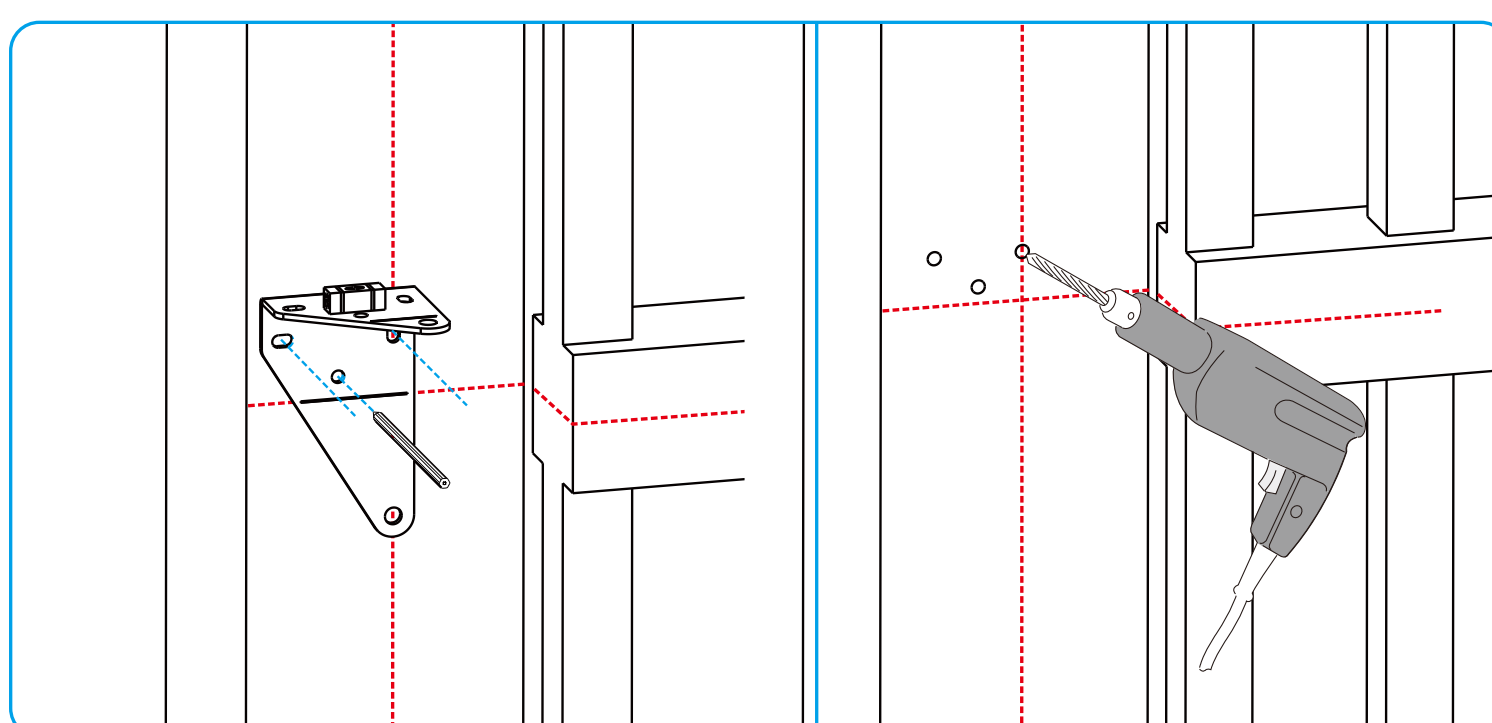

2. Check that the gate fixing bracket is horizontal, then mark the mounting holes for the bracket. Then drill 3 holes in pillar in the locations marked.

i When drilling holes, use the mini level (purchase separately) to ensure the holes are strictly aligned in the horizontal direction.

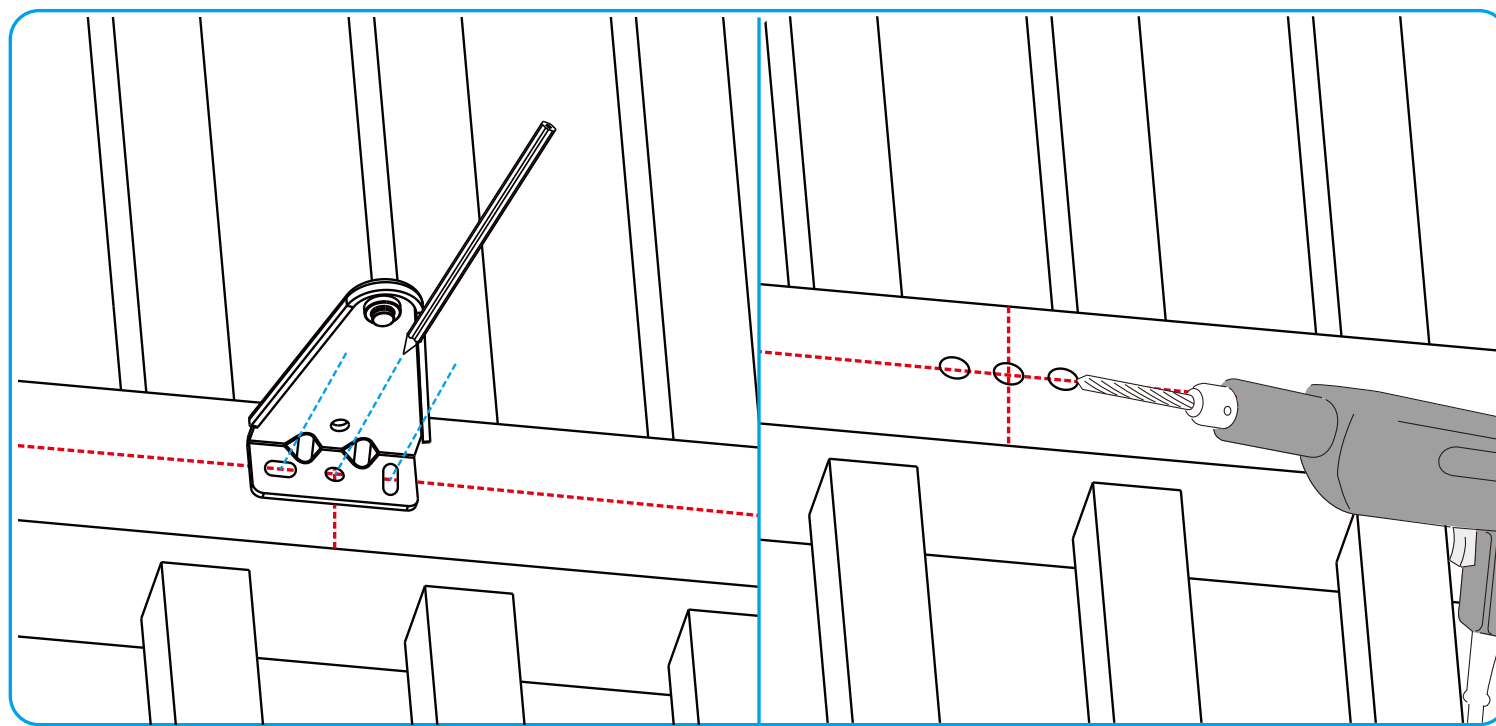

3. Secure the pillar fixing bracket to the pillar with anchors and screws.

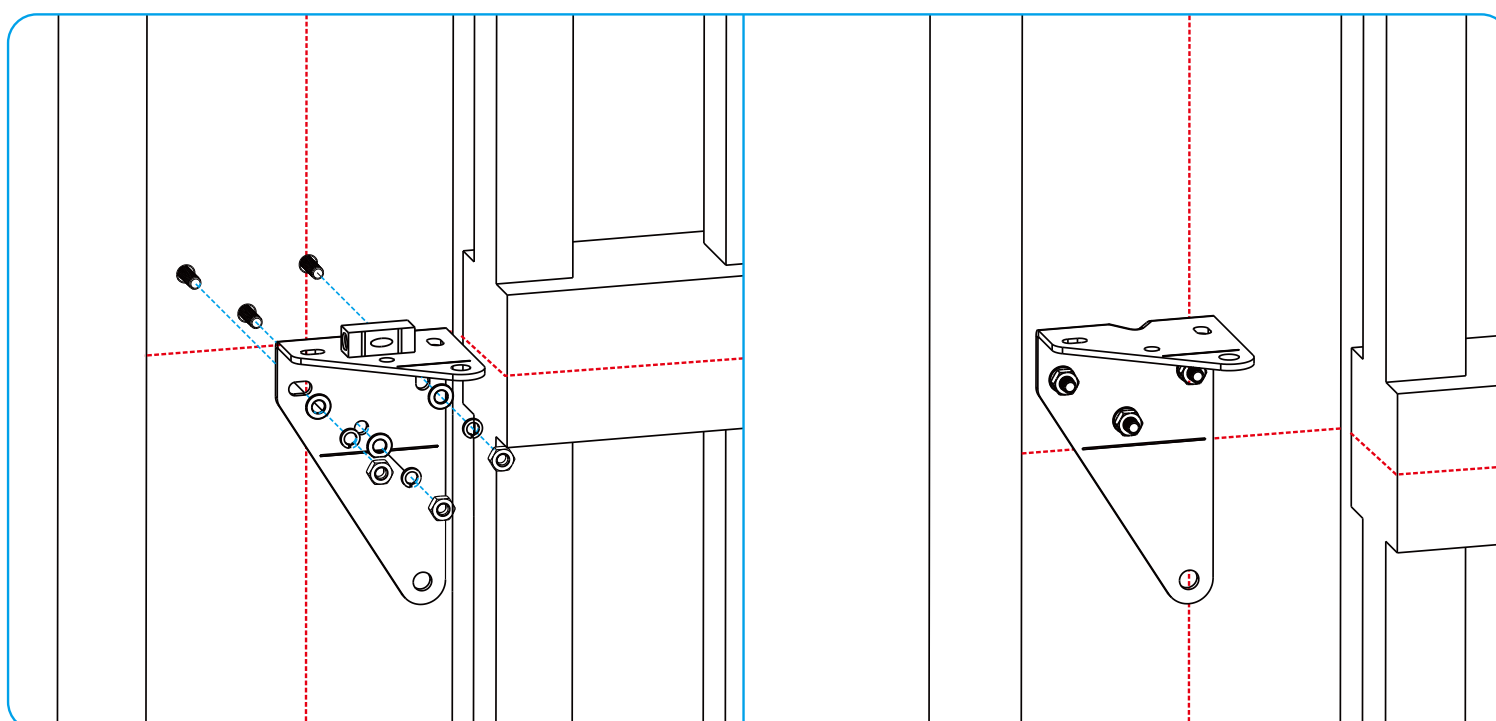

4. Secure the gate fixing bracket to the pillar with anchors and screws.

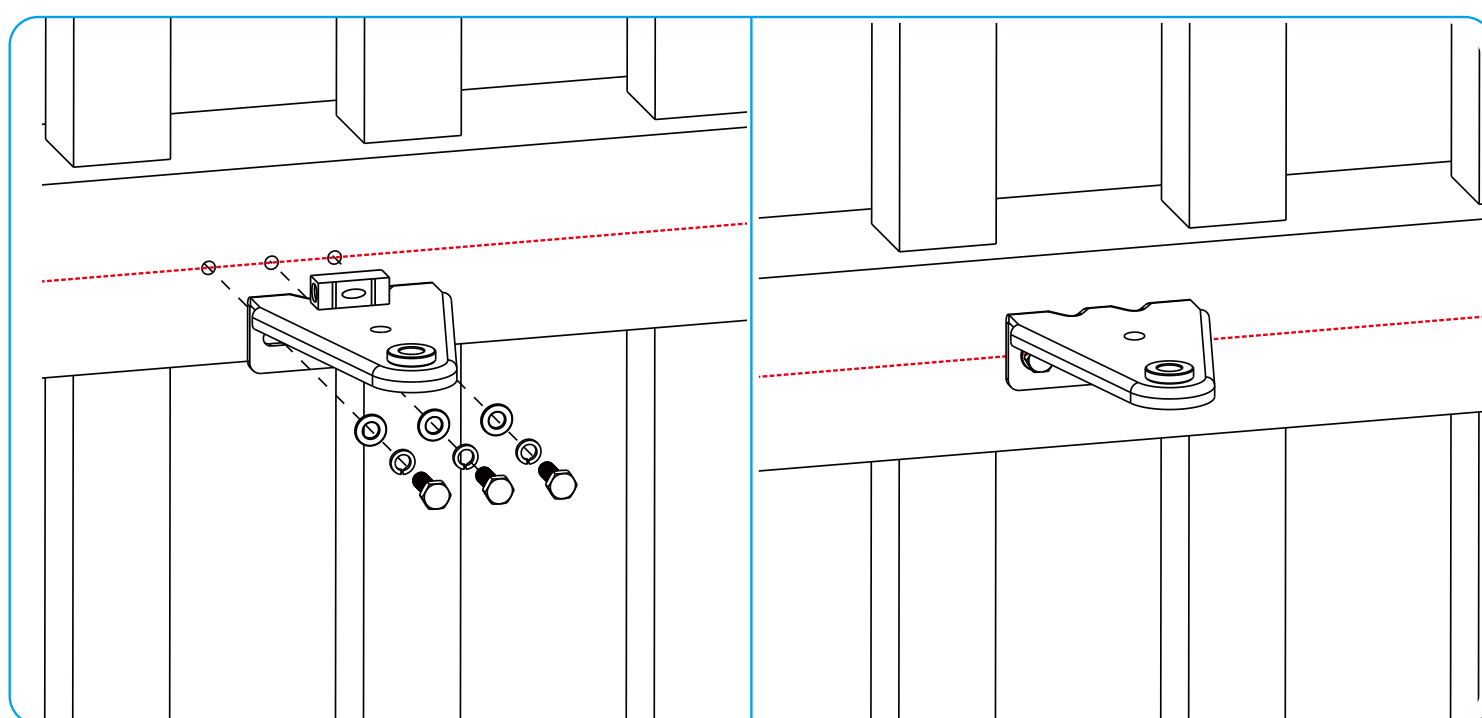

4. Unlock the Cylinder

1. Open the cover on the cylinder with a screwdriver.
2. Insert the key (included in the toolkit) into the keyhole and rotate the key clockwise for 180 degrees to unlock the cylinder in order to be able to manually operate the arms.

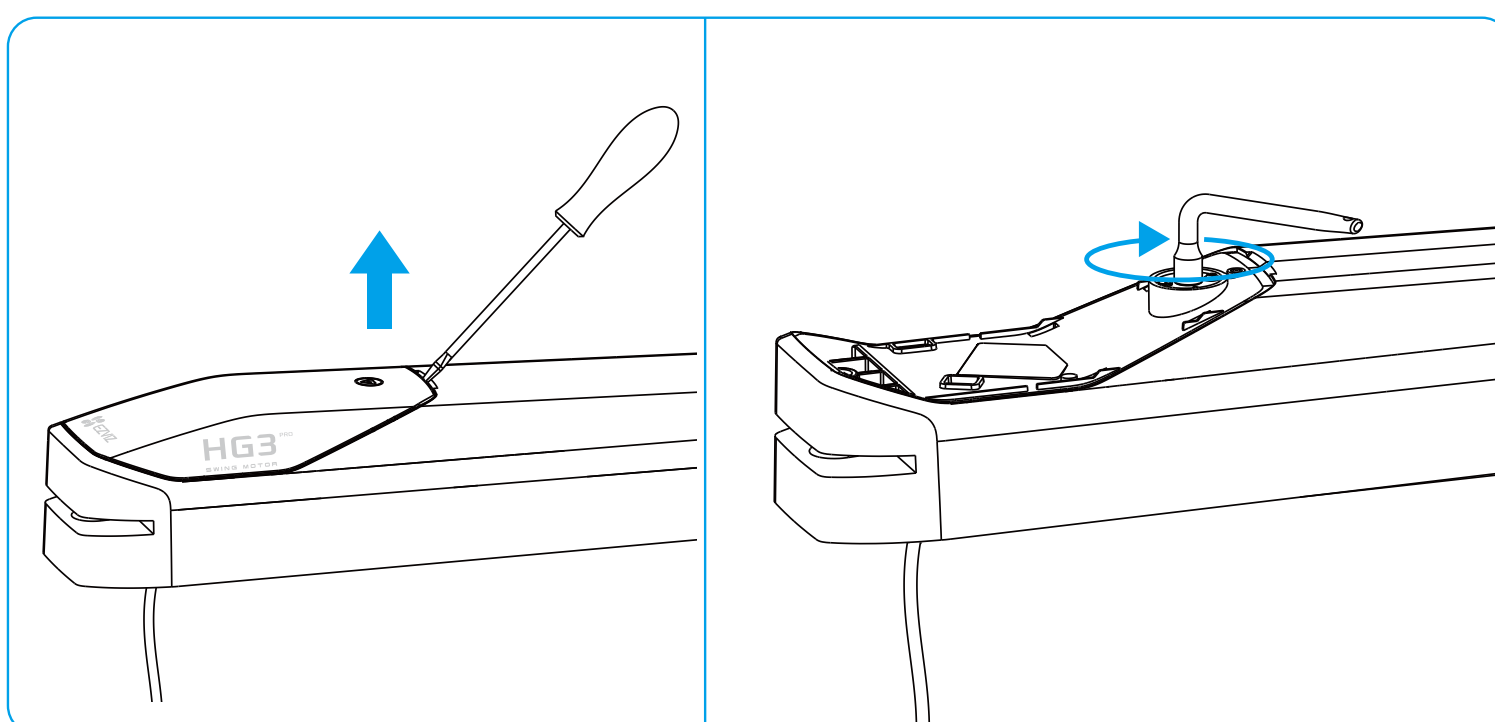

5. Fit the Cylinder onto the Gate and Pillar Fixing Bracket

1. Fit the cylinder onto the gate fixing bracket. Secure the pivot pin with a retaining ring.

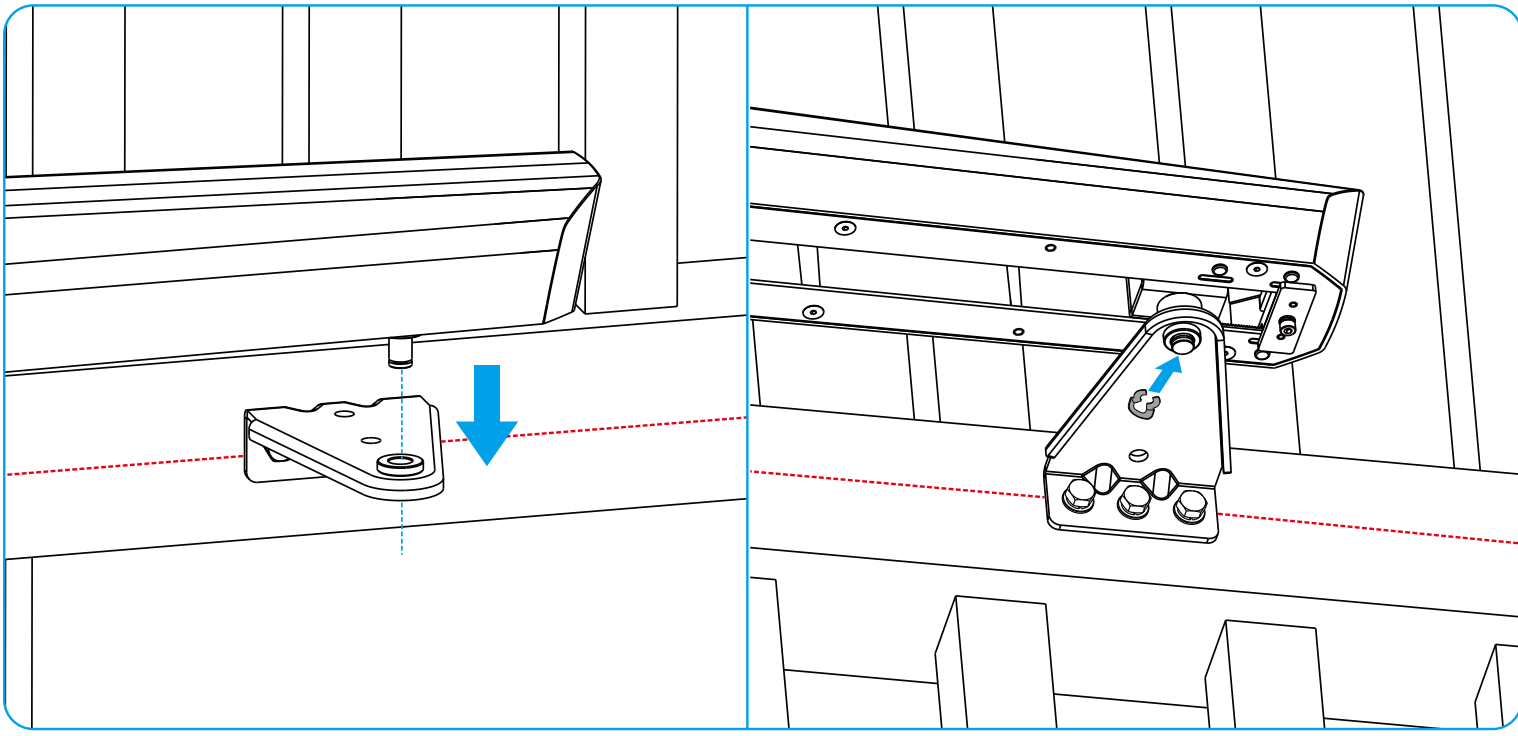

2. Fit the cylinder onto the pillar fixing bracket.

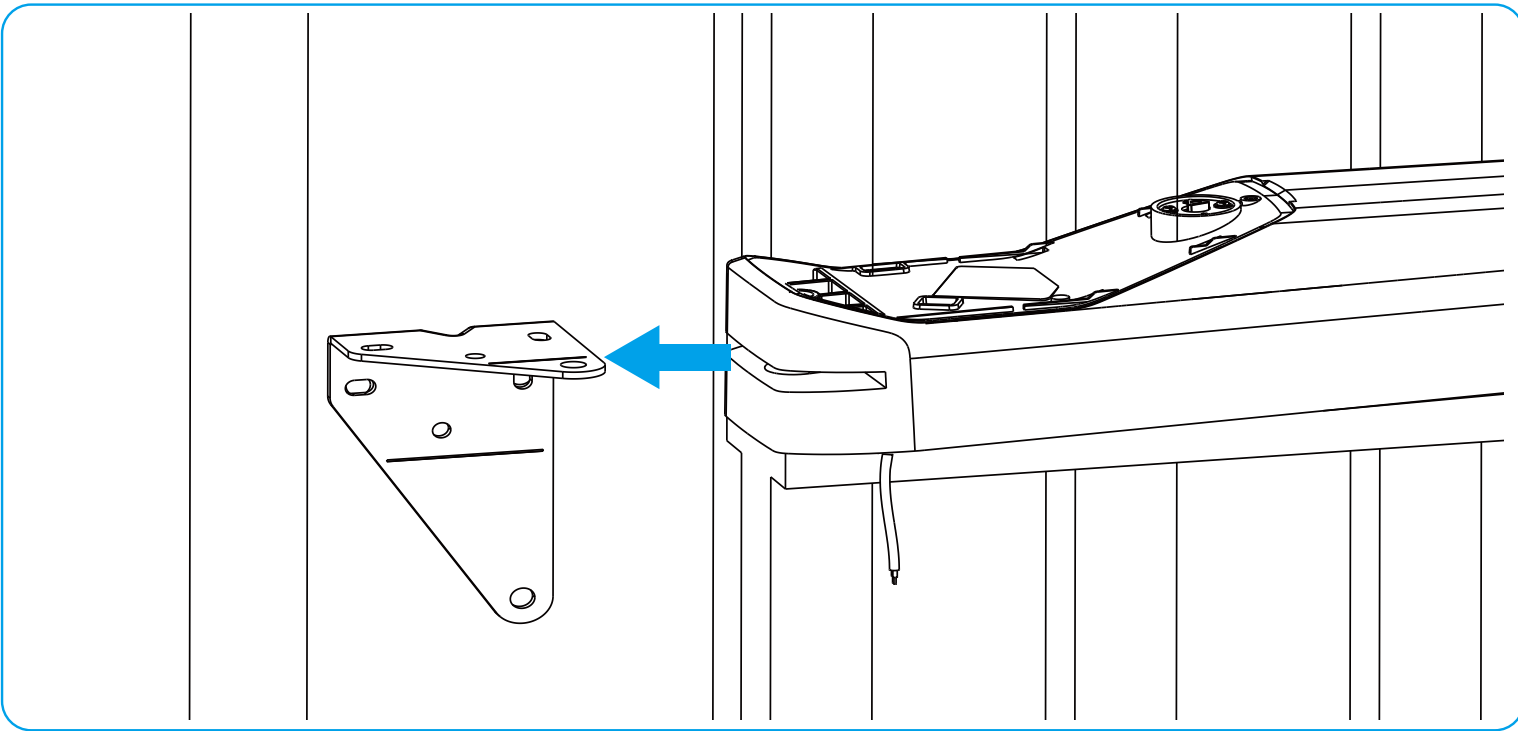

3. Block the cylinder with the pivot pin. Secure the pivot pin with a retaining ring.

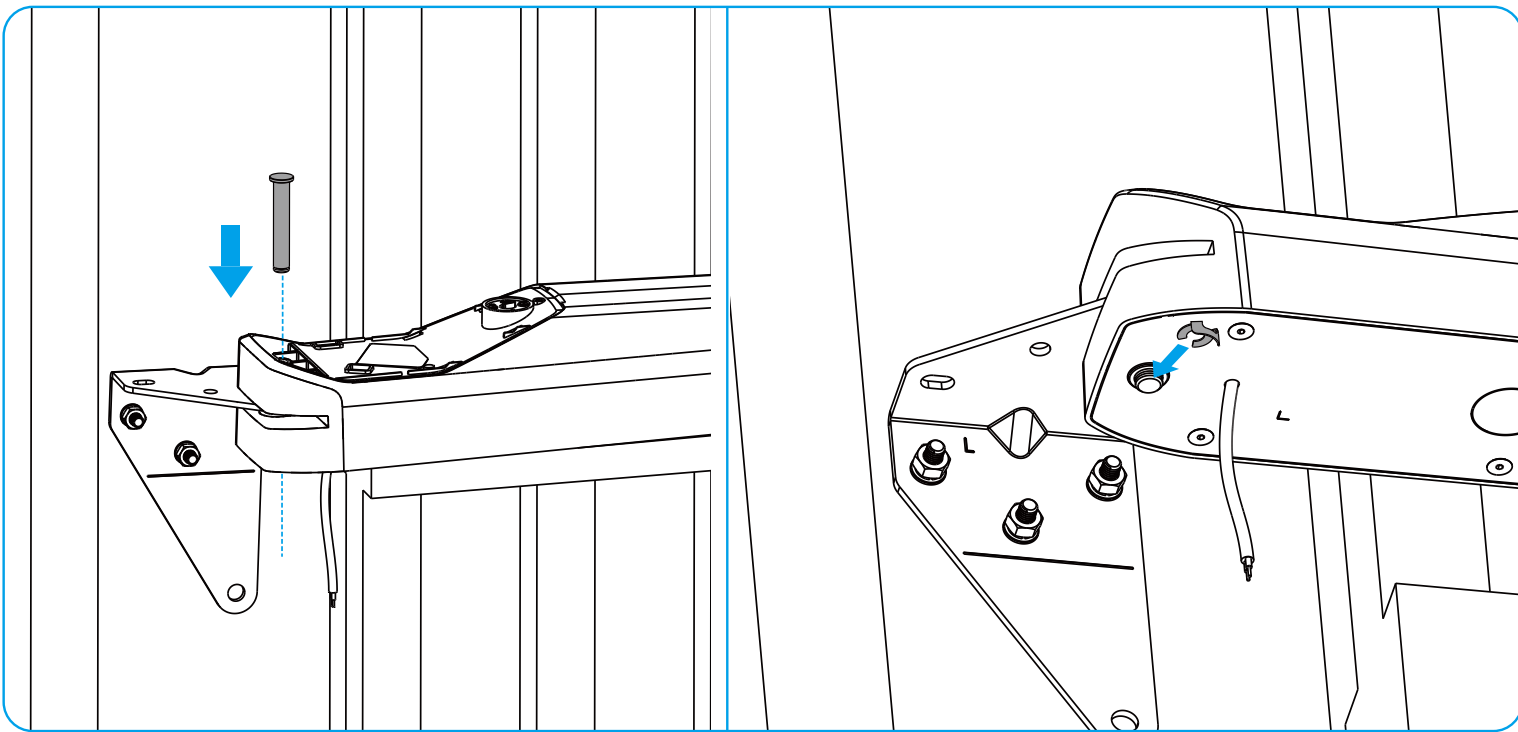

6. Adjust Stop Blocks

The opening and closing stop blocks are directly installed on the cylinders. They are used to limit the travel range of the cylinder, controlling the stopping positions when the gate opens and closes.

It is strongly recommended to adjust the motor stop blocks, regardless of whether your gate is already equipment with stops.

If your gate is already equipped with a central stop and side stops, you can choose not to adjust the motor stop blocks. Note that the stops (both central and side) must hold the gate in a stopped position without locking it. This requires removal of all locking mechanisms, including mechanical strikers, tilting shoes, and retainers.

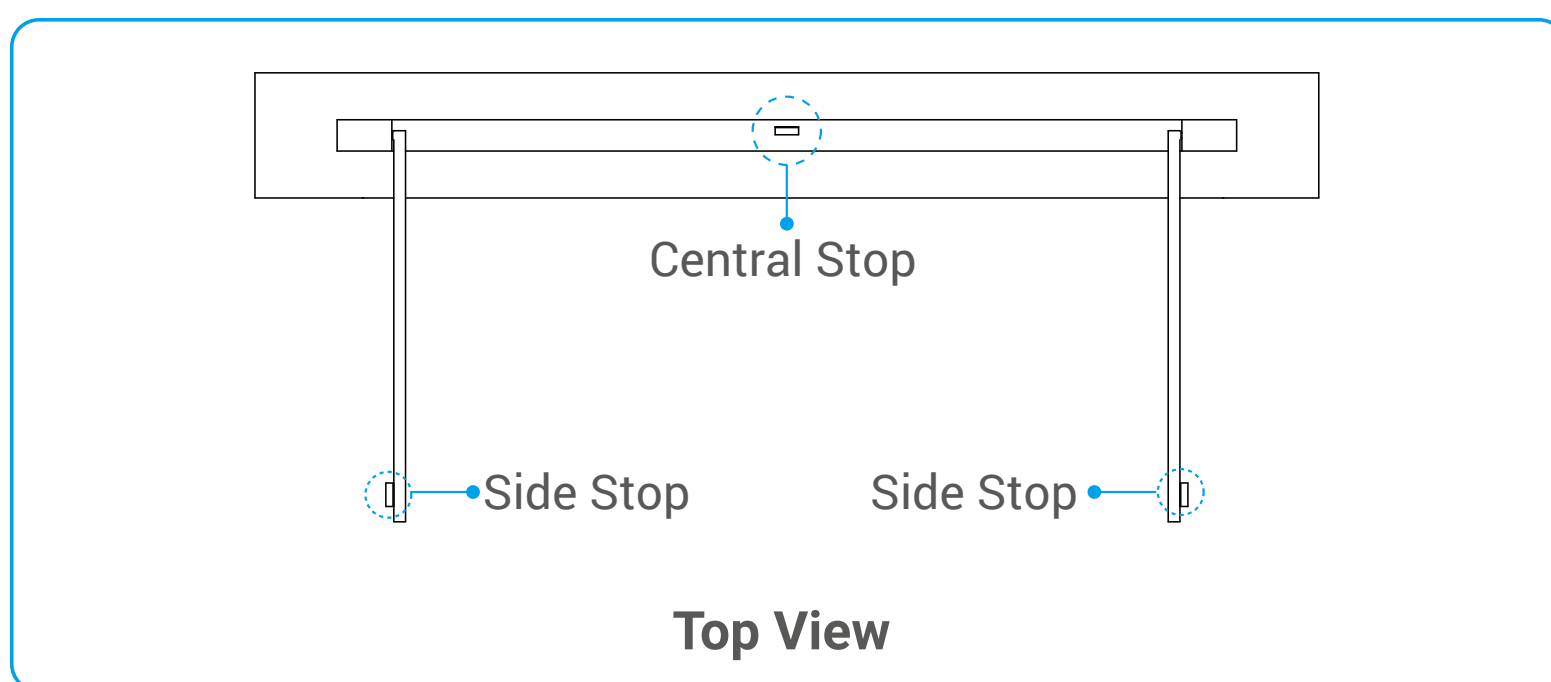

- i** • The position of side stops in the figure above are for reference only.
- If there are limit stops, keep at least 8 mm between the stop blocks and gate fixing bracket to prevent hand pinching.

Loosen the Stop Blocks

Locate the fixing screws on the stop blocks at both ends of the cylinder. Turn the screws counterclockwise with an L-shaped hex wrench to loosen them, the stop blocks can now be moved.

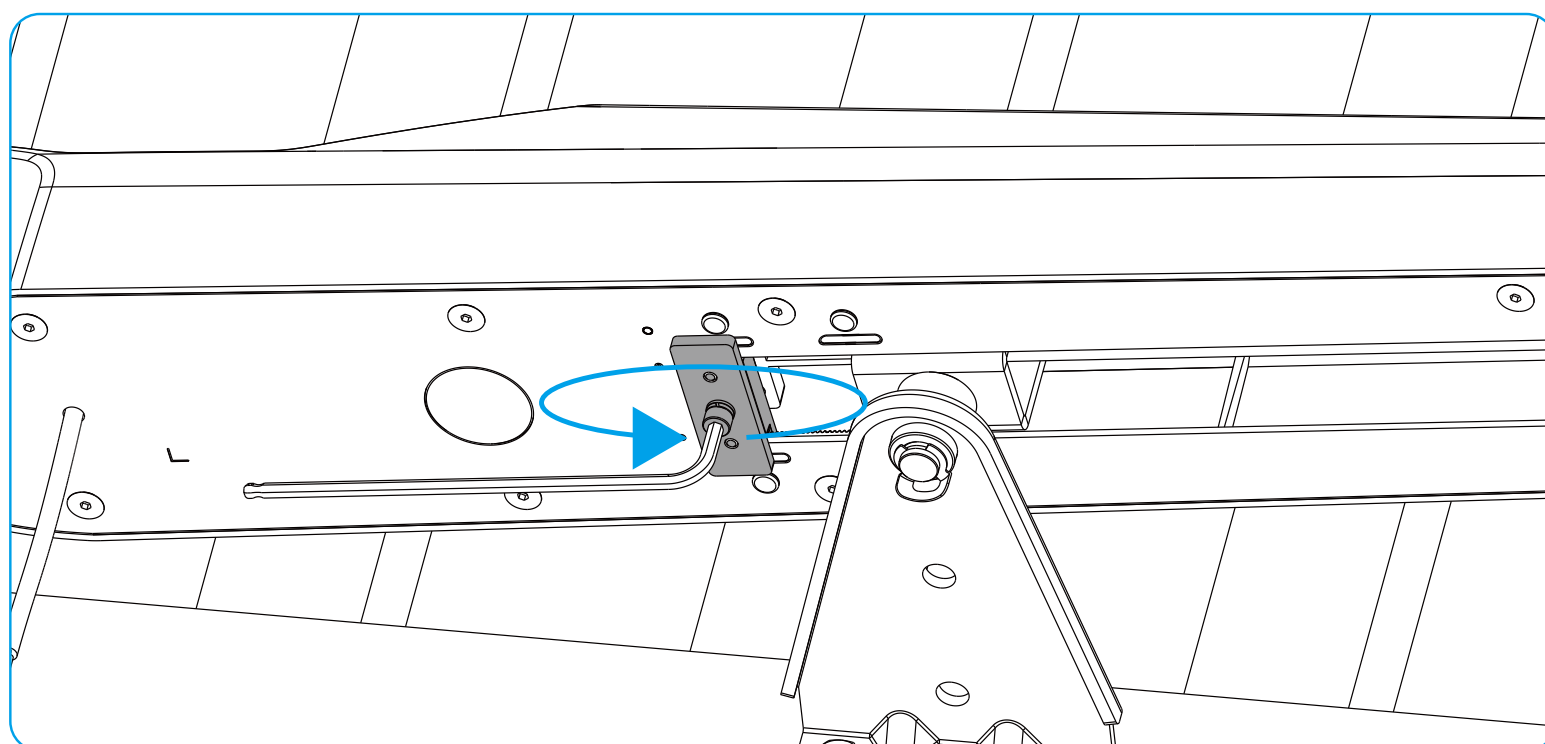

Adjust Opening Stop Block

1. Fully open the gate (to the opening angle).

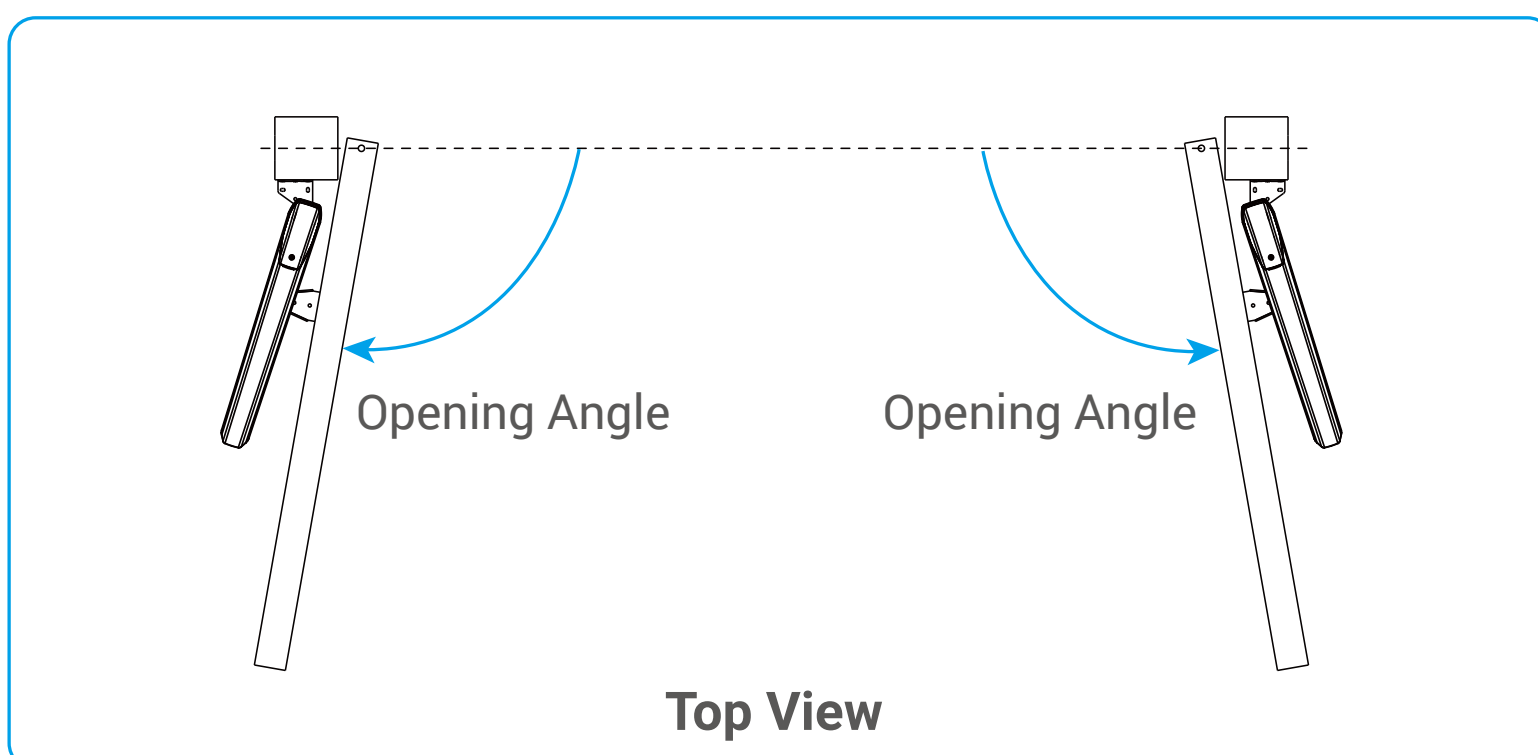

2. Push the stop block toward the cylinder to disengage its teeth from those on the cylinder.

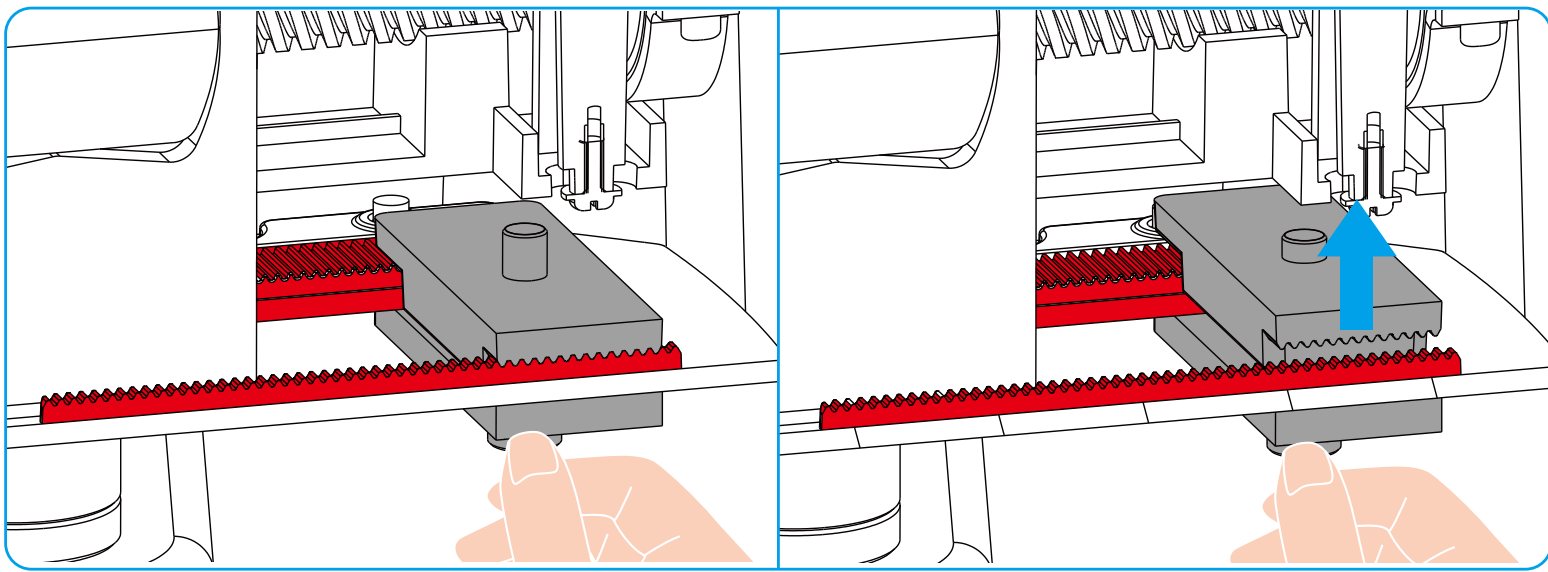

3. Slowly slide the loosened opening stop block toward the pillar fixing bracket until it can no longer move.
4. Tighten the fixing screw of the opening stop block.

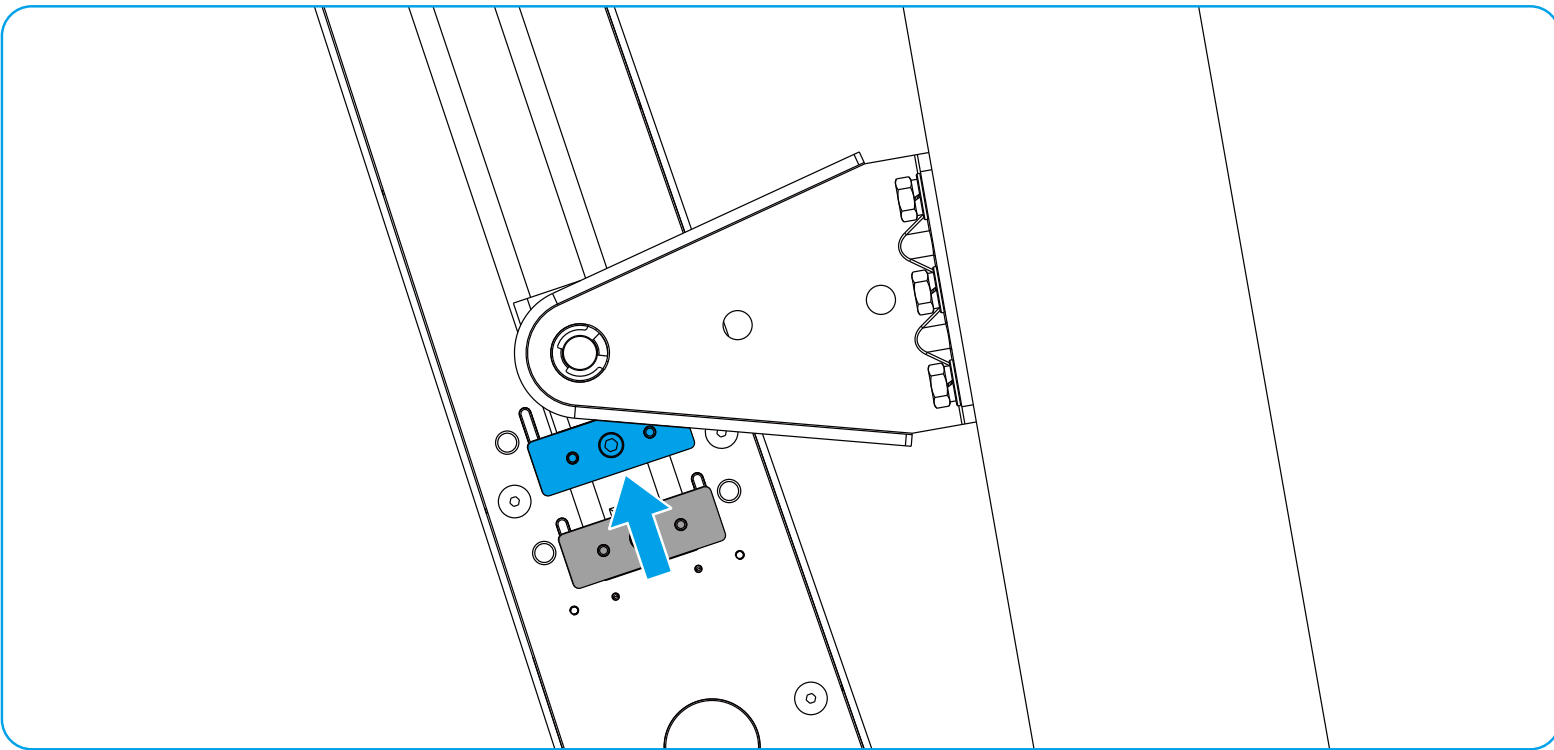

Adjust Closing Stop Block

1. Fully close the gate, ensuring the two gate leaves are perfectly aligned.

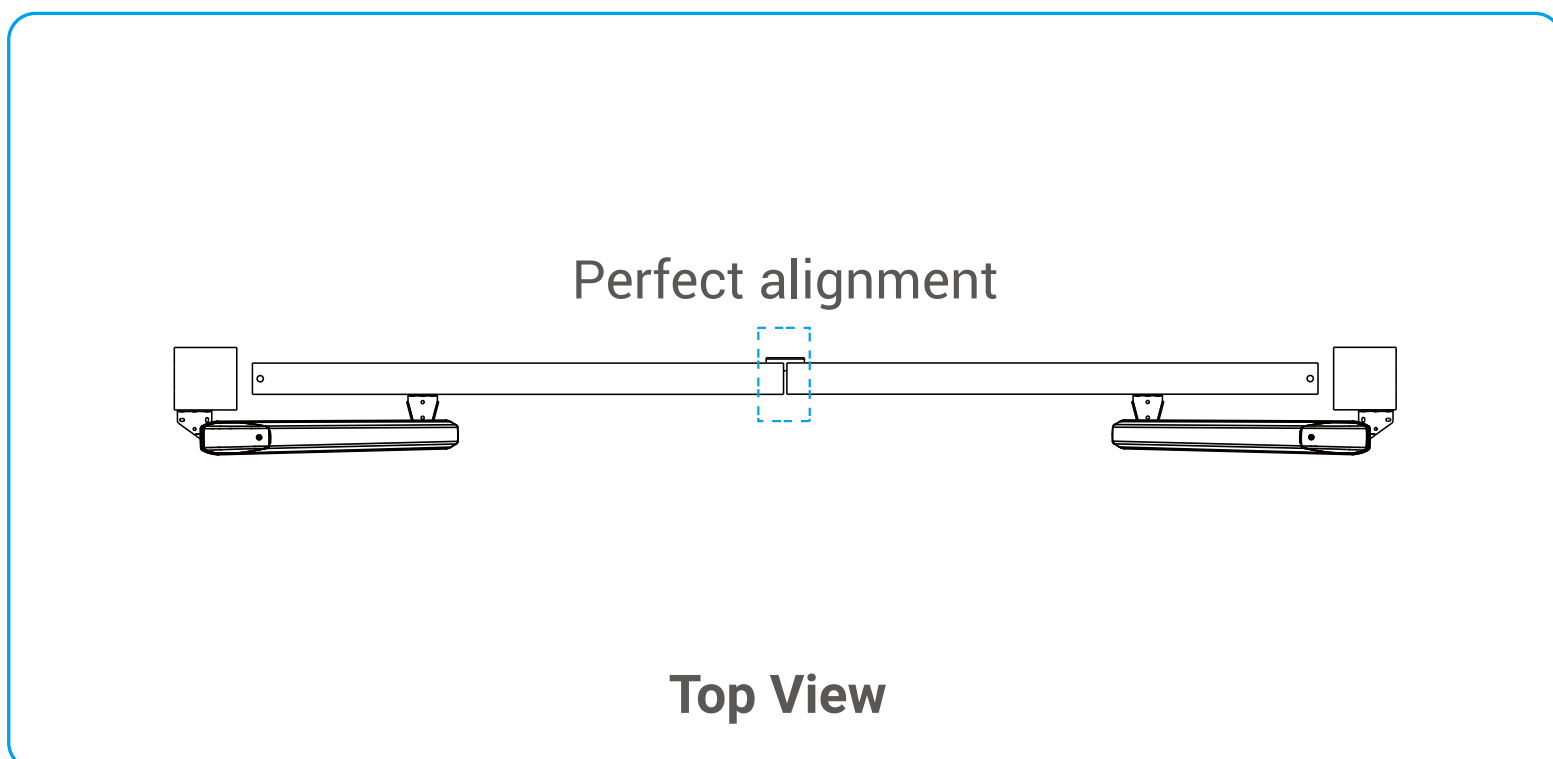

2. Push the stop block toward the cylinder to disengage its teeth from those on the cylinder.
3. Slowly slide the closing stop block toward the gate fixing bracket until it can no longer move.
4. Tighten the fixing screw of the closing stop block.

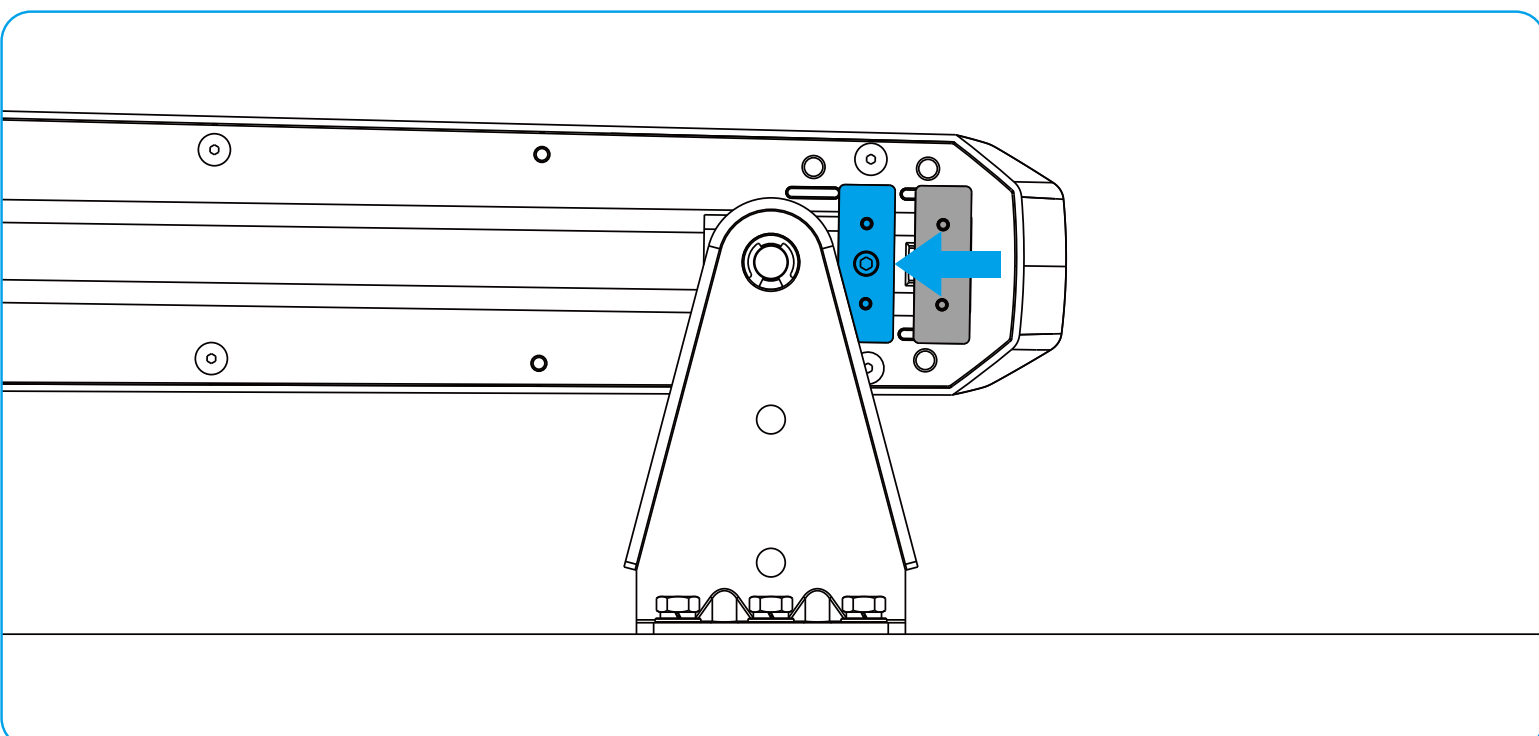

7. Lock the Cylinder

1. Insert the key (included in the toolkit) into the keyhole and rotate the key counterclockwise for 180 degrees to lock.
2. Replace the cover onto the cylinder.

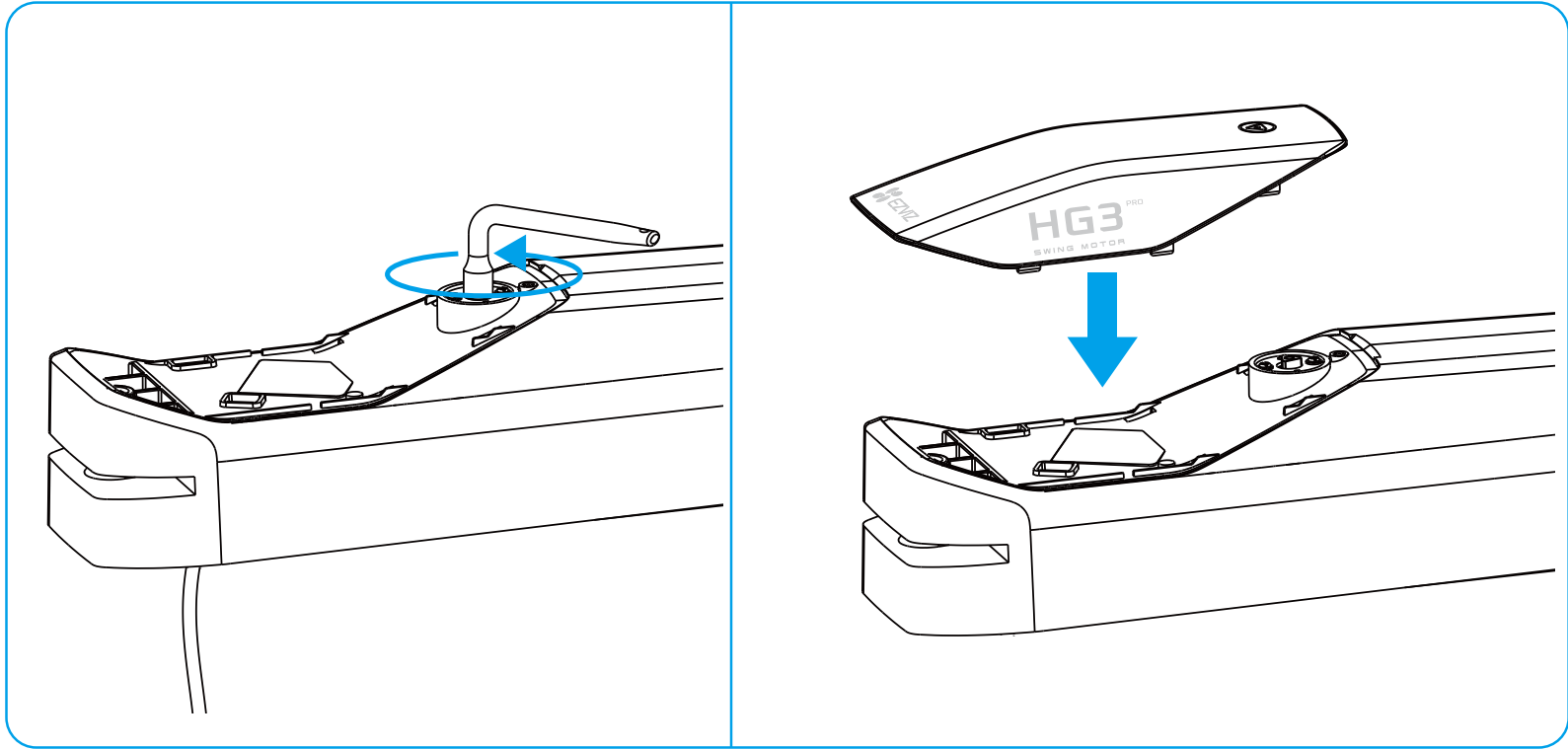

8. Install Control Unit

1. Use a screwdriver to remove the screws from the bottom of the control unit and take off its cover.

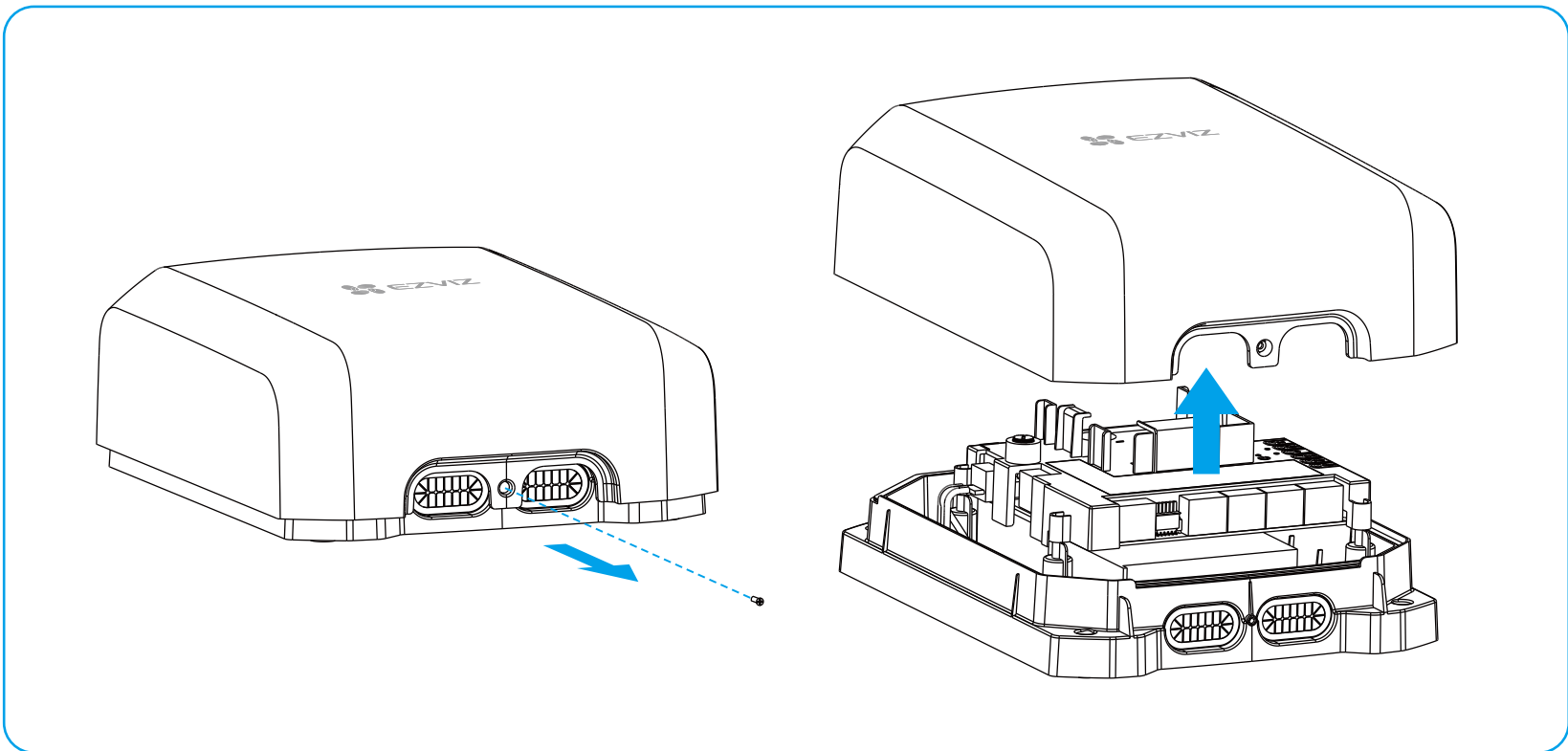

2. Referring to the dimensions in the figure, use a pencil to mark a rectangular frame on the wall at the desired installation position. Mark the drilling points at the four corners of the frame and proceed to drill the holes.
3. Secure the control unit to the wall with anchors and screws.

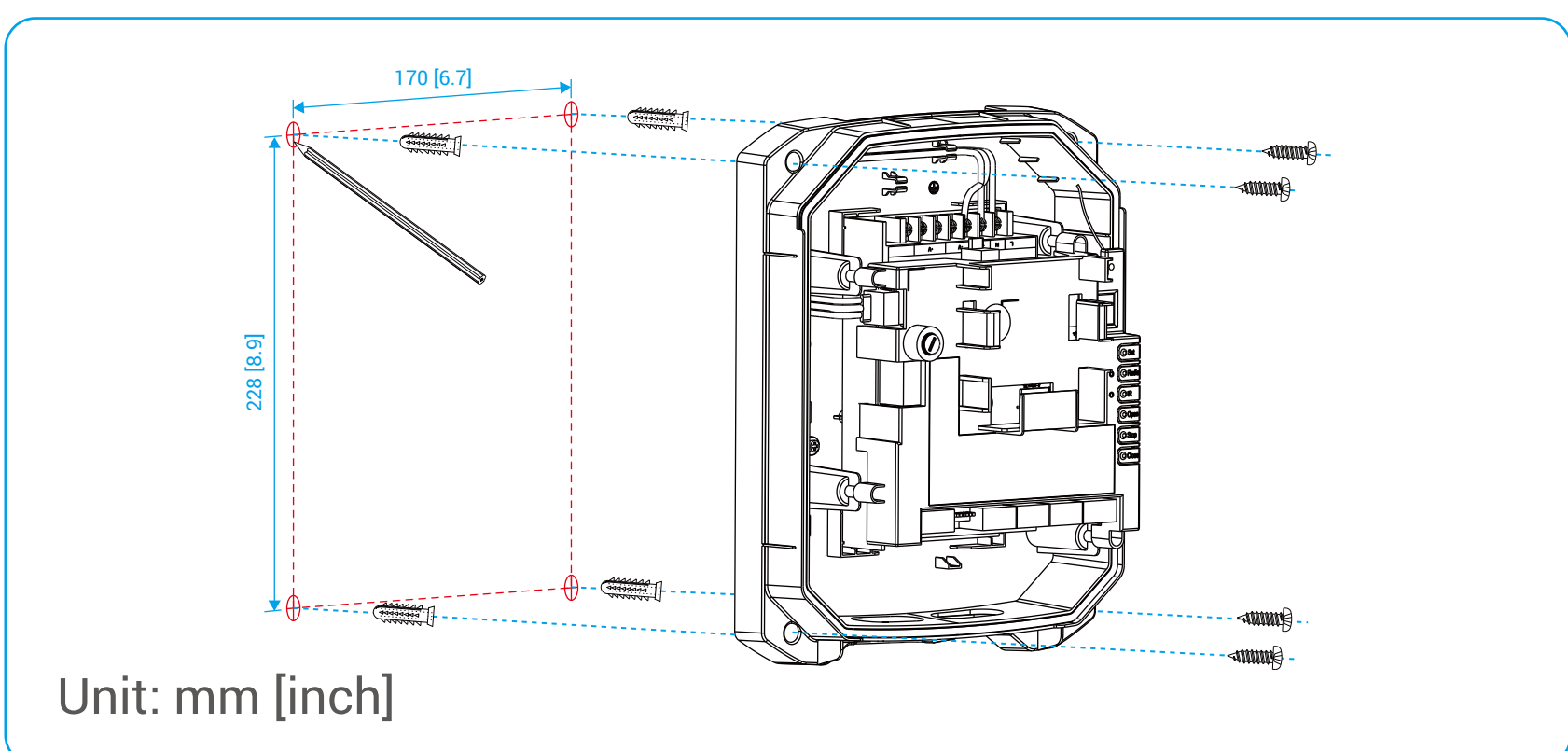

9. Connect the Power Cable

- ⚠ • The gate opener requires a power cable (with a plug, not included) to connect to an external power supply, or must be connected to a dual power switch compliant with EN 60664-1.
- Be sure to open the circuit breaker to be used for the gate opener first.

1. Connect the live wire (red wire in the figure) to the L interface and the neutral wire (black wire in the figure) to the N interface (refer to the sticker on the control unit, as shown below).

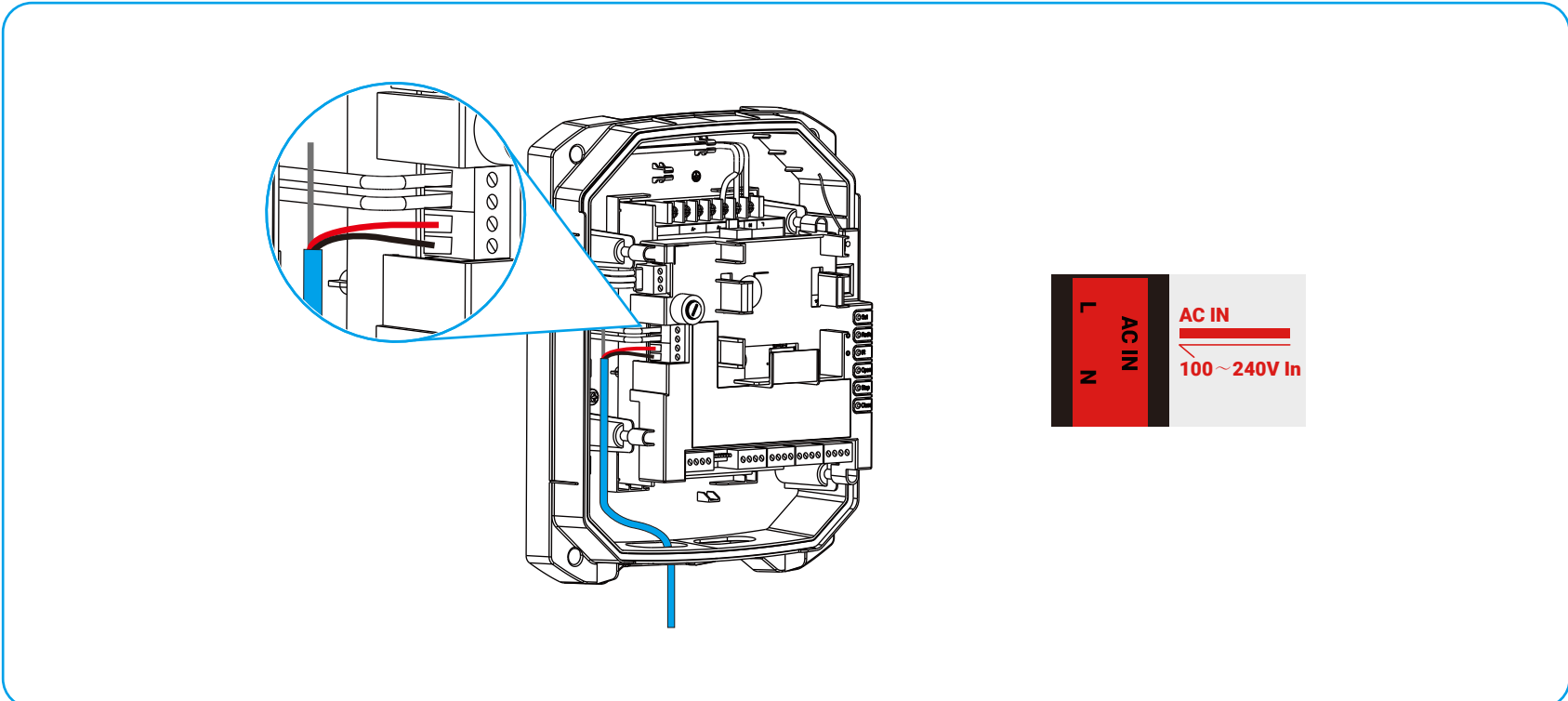

2. Connect the earth wire (not included) to the earthing rod.
 - a. Loosen the screw on the earthing rod.
 - b. Connect the ground wire to the earthing rod's screw.
 - c. Tighten the screw on the earthing rod.

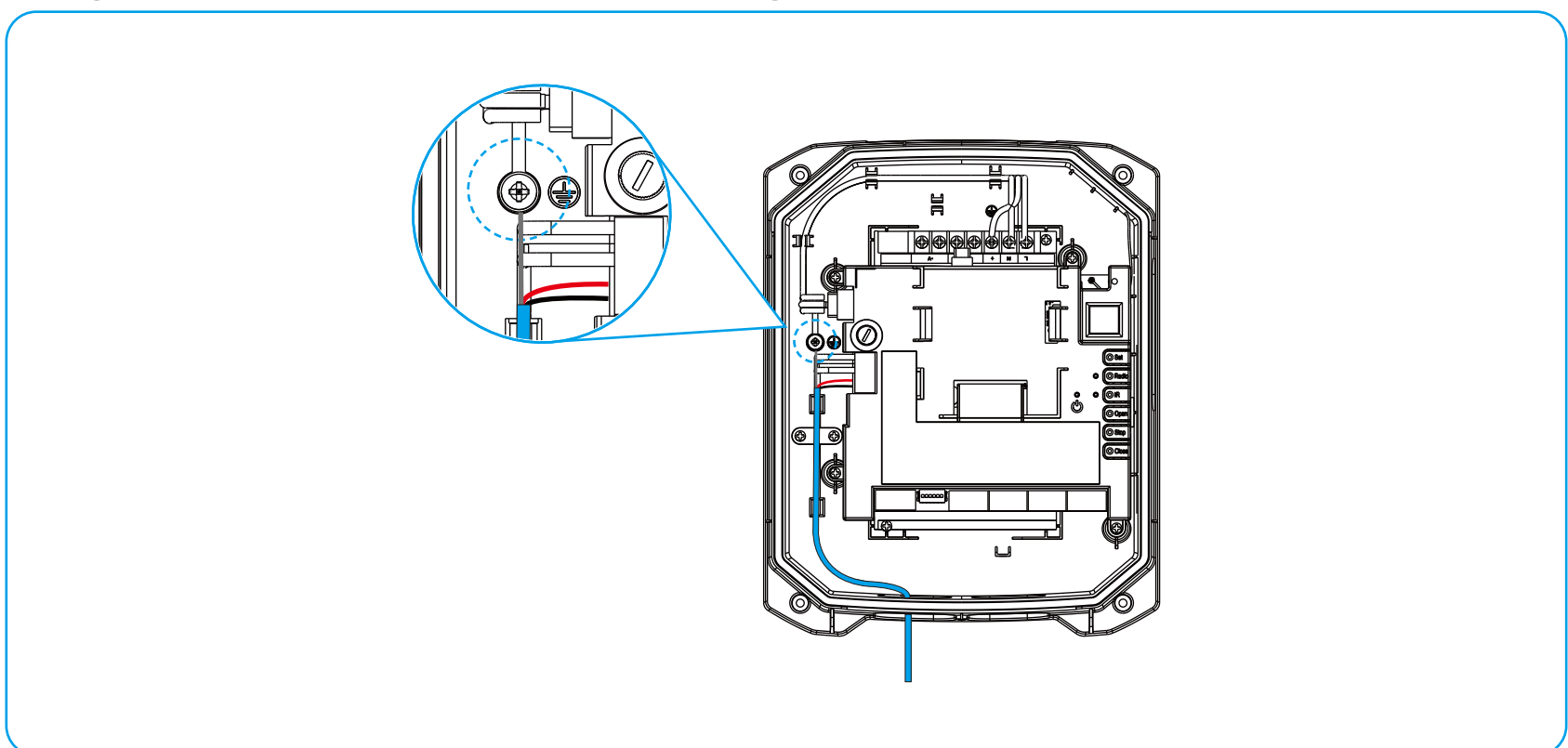

10. Connect the Cylinder

1. Loosen the four screws on the terminals 1 and 2 ("MOTOR 1"), 3 and 4 ("MOTOR 2") on the control unit.
2. Insert the two wires of the cylinder into the terminals 1 and 2, 3 and 4 separately.

- i** • Make sure to connect the cylinder at the primary gate to MOTOR 1.
- Red wire to positive, black wire to negative.
- The cylinder comes with a power cable. If an extension is needed, the cable (purchase separately) used must at least comply with the 60227 IEC 52 standard.

3. Tighten the screws back on the four terminals.

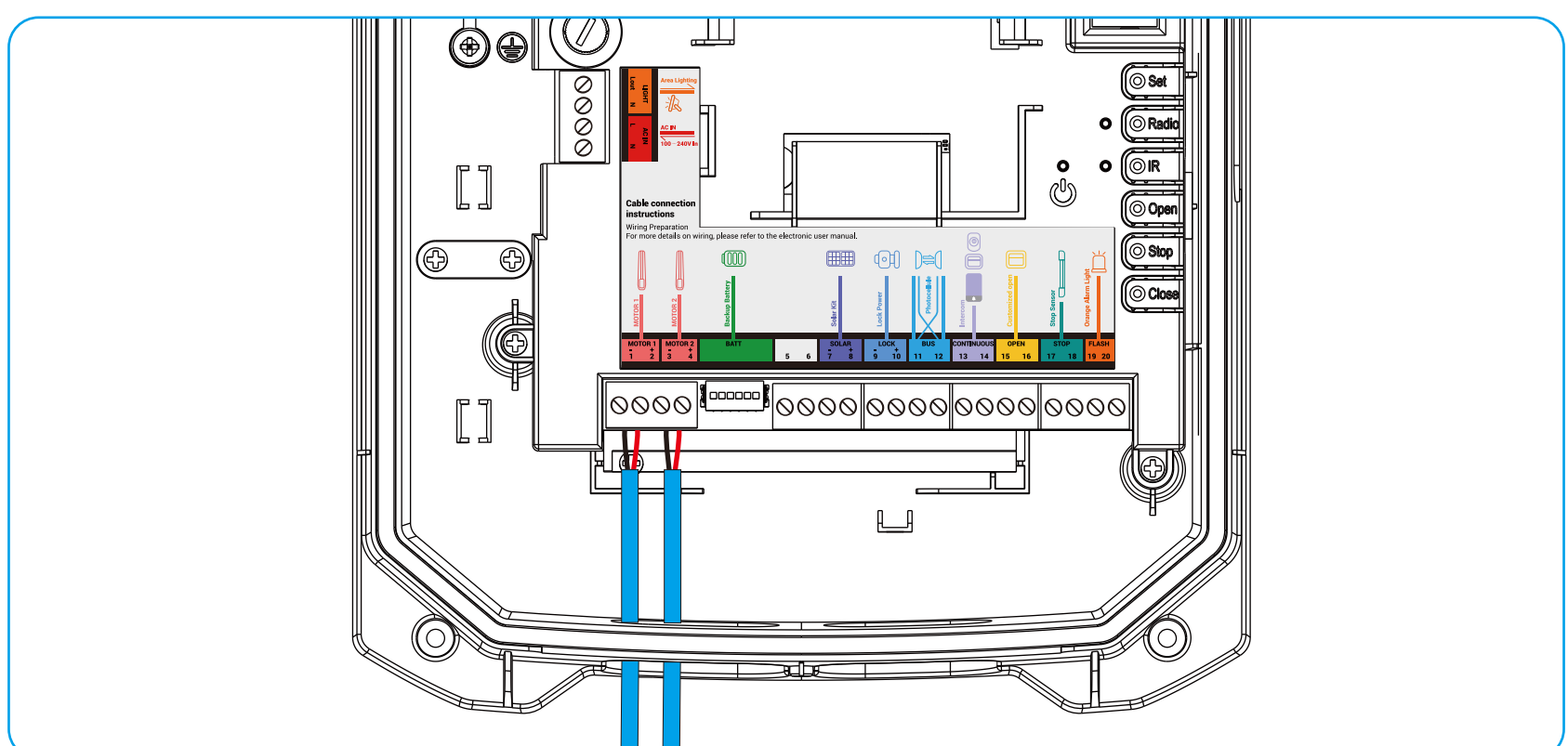

Install the Photocellules

Based on the emission of infrared beams, the photocellules are used to detect the passage of a person or vehicle through the gate to prevent from causing any harm or damage during gate closing. Cutting the photocellule beam should cause the gate to stop immediately.

1. Components Required

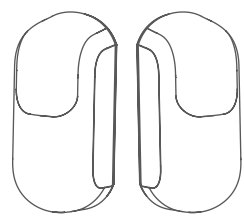

Photocellule (x2)

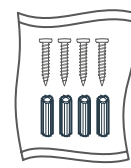

Screw Kit (x1)

2. Basics of Photocellules

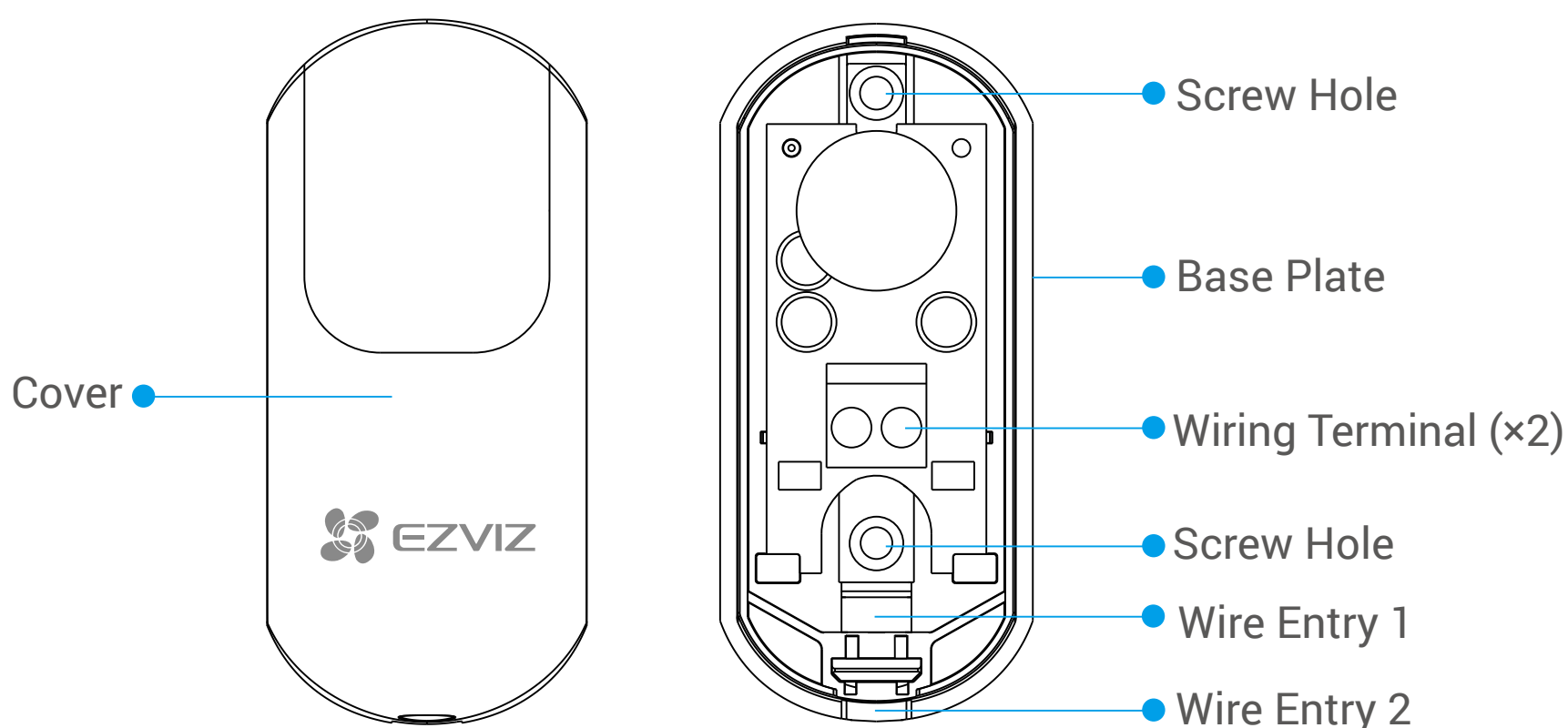

3. Installation Procedure

- Do not install the photocellules onto unstable surfaces.
- If you install the photocellules where there are direct light rays or sunlight, measures should be taken to protect the internal optical components of the photocellules from the light rays or sunlight.
- The photocellule RX should only receive light rays emitted by the photocellule TX. Do not direct infrared light rays emitted by other detectors at the photocellule RX.
- Be sure to install the two photocellules at the same and appropriate height (recommended height: 0.5 meters above the ground).
- Recommended horizontal distance between the photocellules: 3-8m.
- Two pairs of photocellules can be installed at most. Do not install two TXs (or RXs) on the same side.

Preparation

1. If any existing photocellules are installed on the pillar, remove them first. The wires can be retained for use.
2. Ensure that the environment meets the installation requirement. Use a tape measure to help determine an appropriate installation location on the pillar. It is recommended that the photocellules should be installed at a height of about 50cm above the ground and the photocellules can be installed either inside the gate or outside the gate on the pillar.
3. One pair of photocellules are provided in the package. The two photocellules should be installed on both pillars separately, with no specific requirements on which pillar the TX or RX should be installed.
4. Each photocellule requires two wires for connection to the gate opener. If there are four concealed wires, choose any two of them.

Install the photocellules

1. Take the photocellule (TX or RX) out of the box. Use a screwdriver to loosen the screw on the bottom of the cover. (Keep the screw properly.)

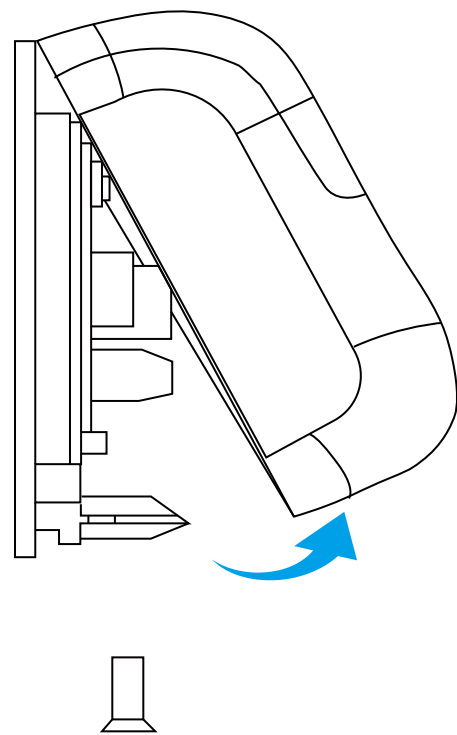

2. Grab the lower part of the cover and flip it upwards to separate the cover from the base plate.
3. Use the base plate and a tape measure to select an appropriate installation location on the pillar. It is recommended that the location should be at a height of about 50cm above the ground (as shown below).

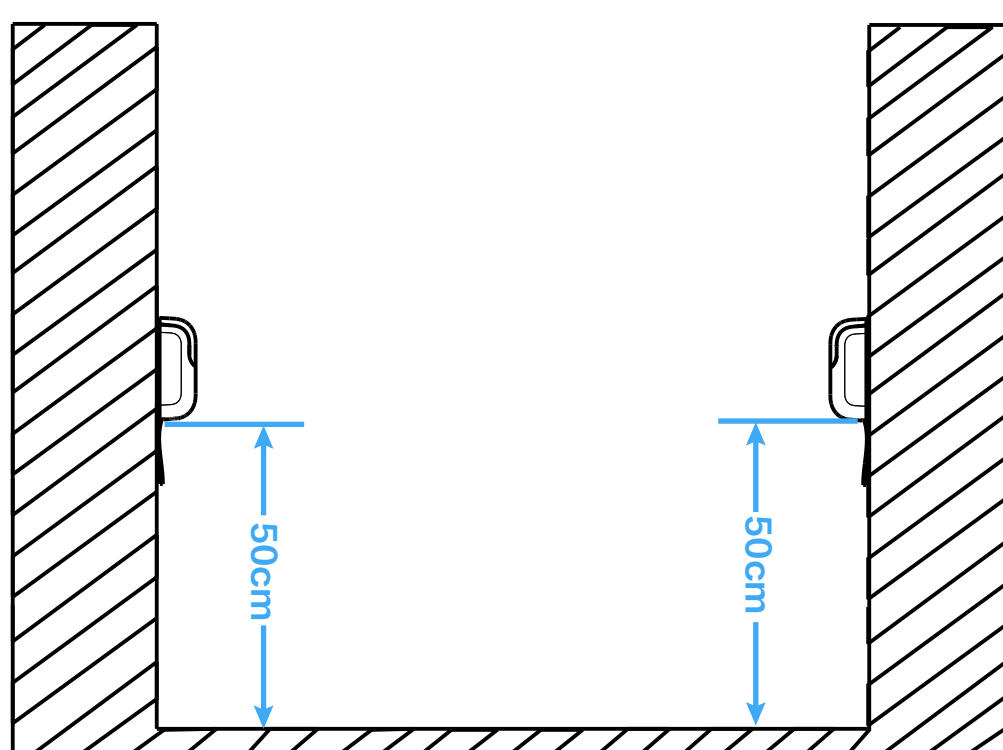

i The photocellules can be installed either inside the gate or outside the gate on the pillar.

4. Use a marker to mark two anchoring points according to the two screw holes on the base plate.
5. Take the base plate away and use a drill bit to drill two holes (drilling depth: 25-30mm) at the two anchoring points.
6. Connect wires.
 - a. Loosen the two screws on the wiring terminals.
 - b. Guide two wires through the wire entry 1 (if you are using concealed wiring) or wire entry 2 (if you are using visible wiring) and insert them into the wiring terminals separately.

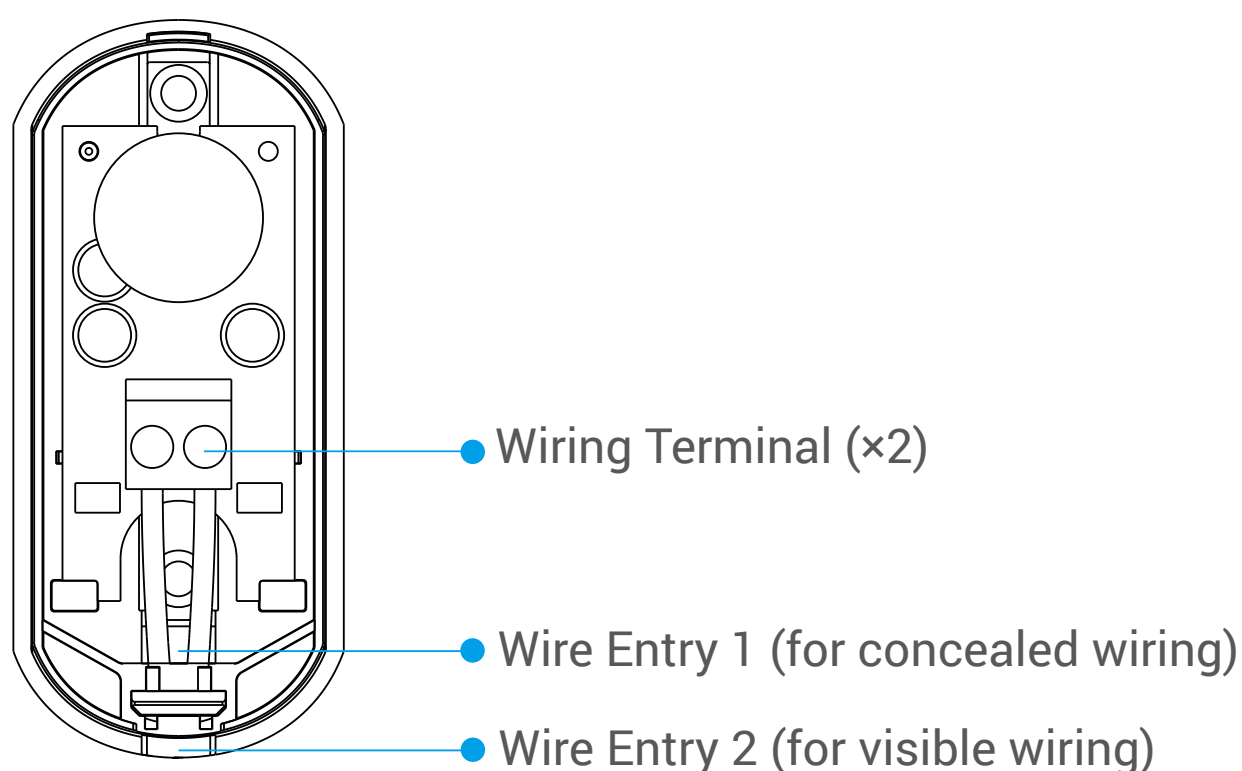

- c. Tighten the two screws back on the wiring terminals.

i

- The two wiring terminals on the base plate are polarity-insensitive.
- Make sure that the screws are tightened properly and the wires will not fall off.
- Be careful not to short-circuit the two wires.

7. Insert two anchors into the holes on the pillar and hammer them just into the holes.

- Align the two screw holes of the base plate with the two holes on the pillar and fix two screws into the screw holes.

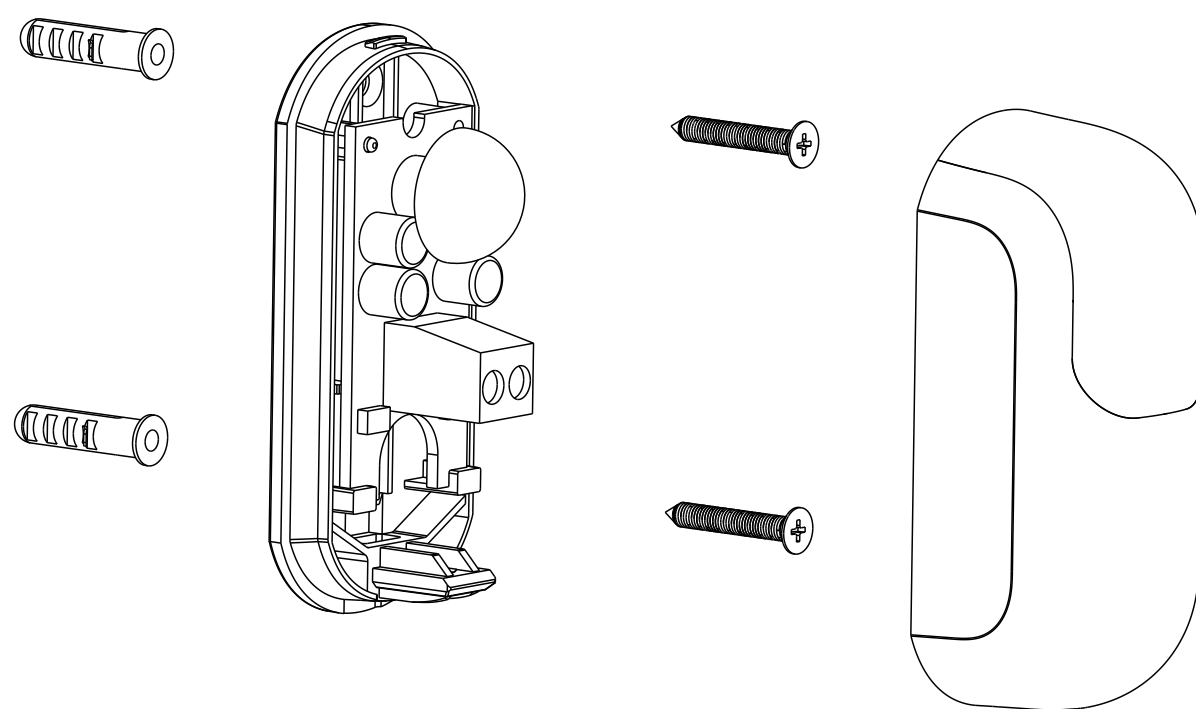

- Install the cover onto the base plate (from the top down) and tighten the screw back (loosened in step 1) on the bottom of the cover.

After one photocell is installed, repeat the steps above to install the other photocell, making sure that the two photocells are fixed at the same height and the two photocells are aligned as shown below.

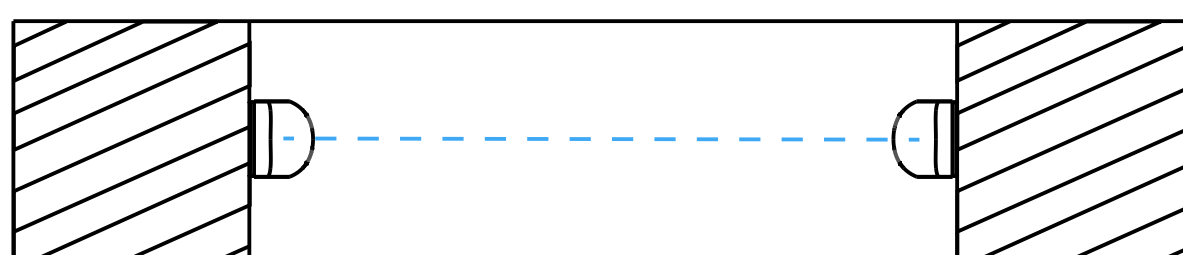

Top View

Wiring on the gate opener

- Loosen the two screws on the terminals 11 and 12 ("BUS") on the control unit.
- Insert the two wires of one photocell into the terminals 11 and 12.
 - i • Do not insert the two wires into the same terminal.
 - Make sure that the screws are tightened properly and the wires will not fall off.
 - Be careful not to short-circuit the two wires of the same photocell.
- Insert the two wires of the other photocell into the terminals 11 and 12.
- Tighten the screws back on the two terminals.
- Use a cable tie to fix the wires in the cable holder.

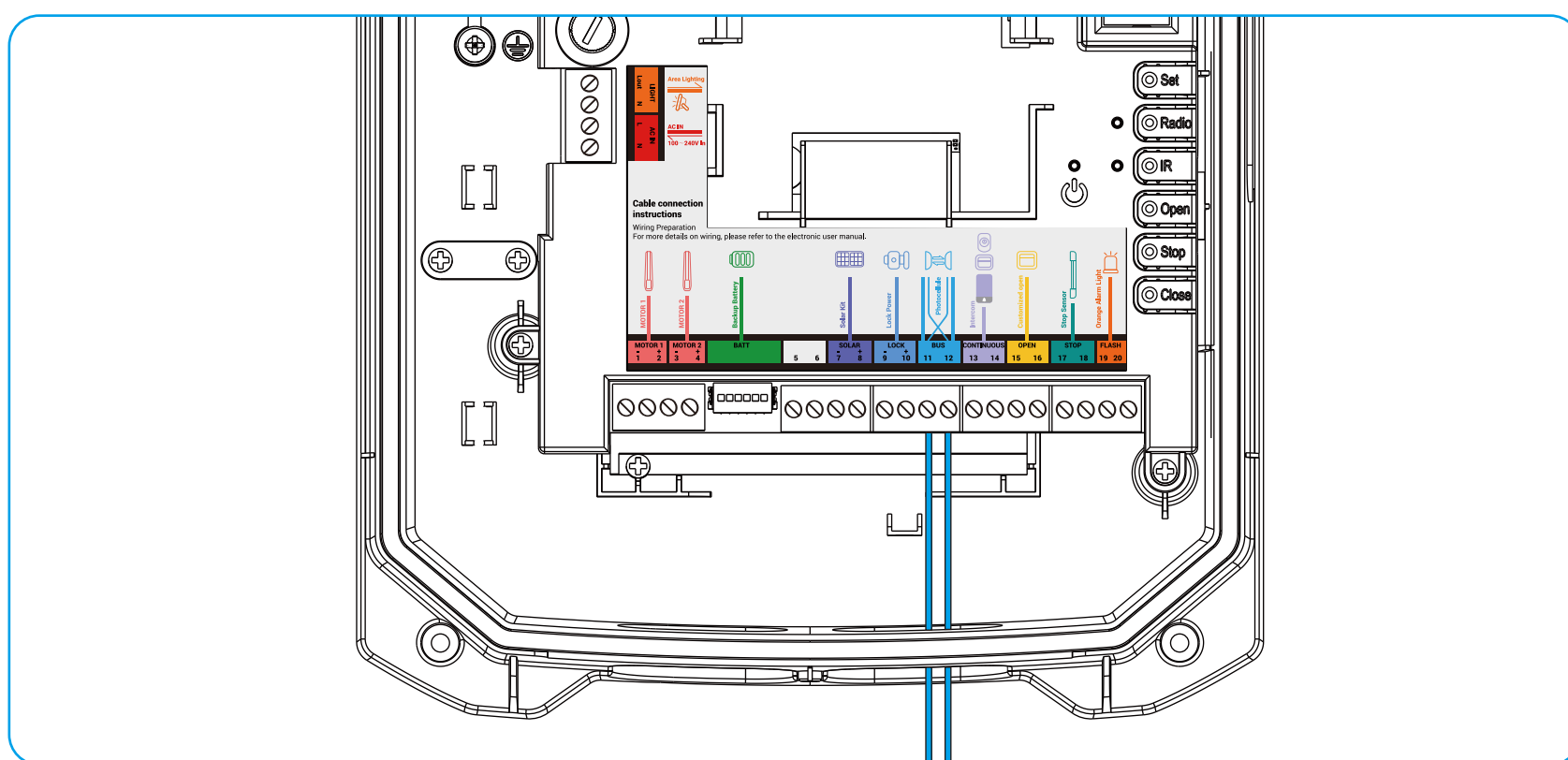

Install the Alarm Light Camera

1. Components Required

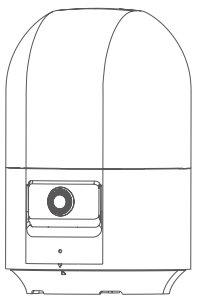

Alarm Light Camera (×1)

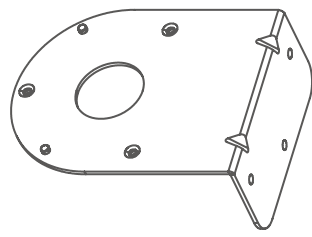

Wall Bracket (×1)

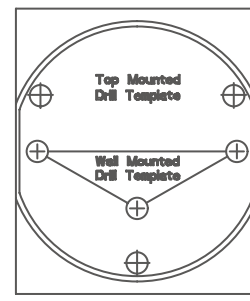

Drill Template (×1)

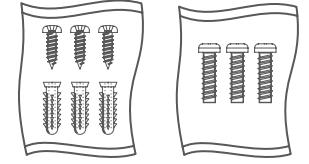

Screw Kit (×2)

2. Basics of Alarm Light Camera

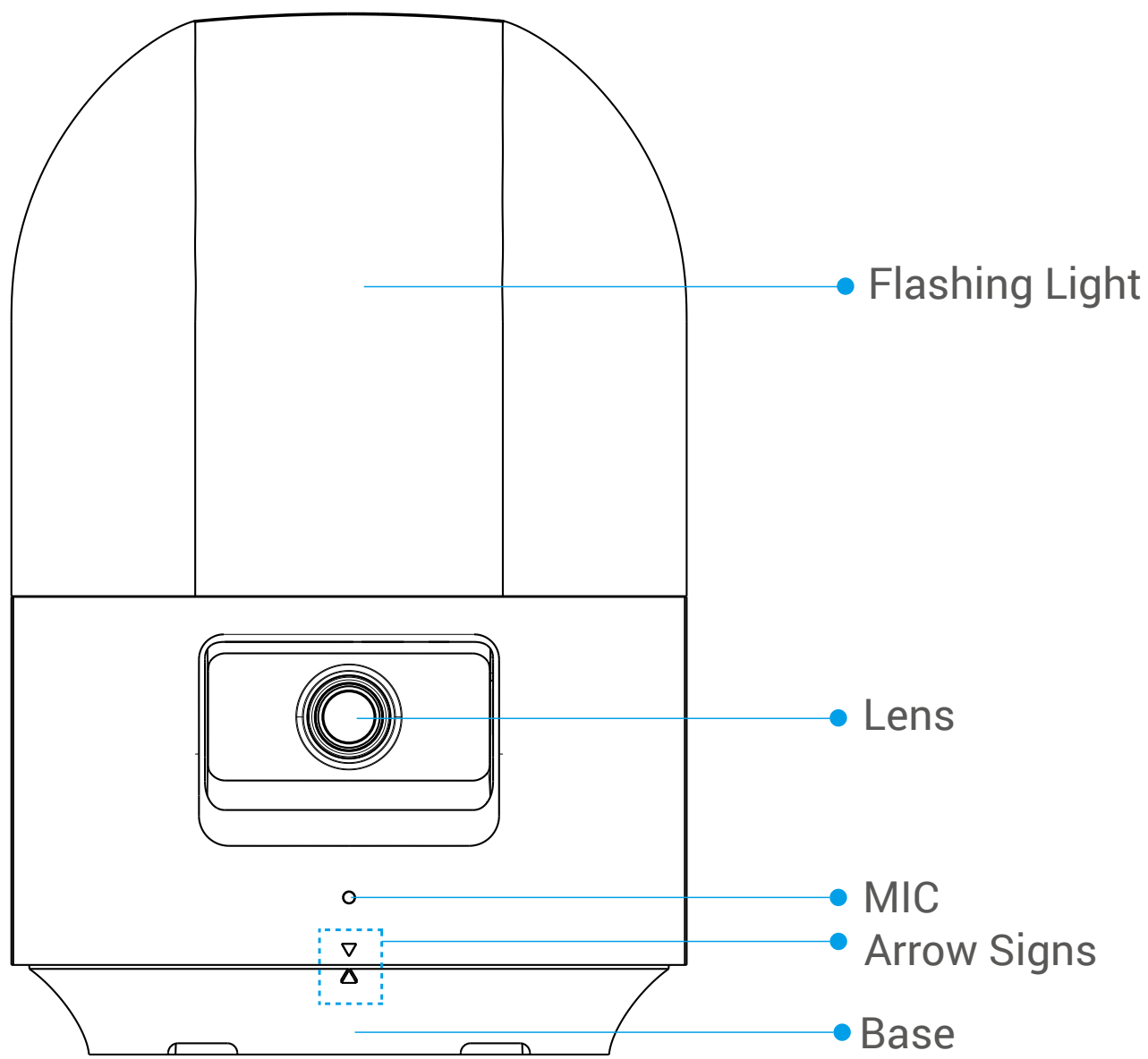

Front View

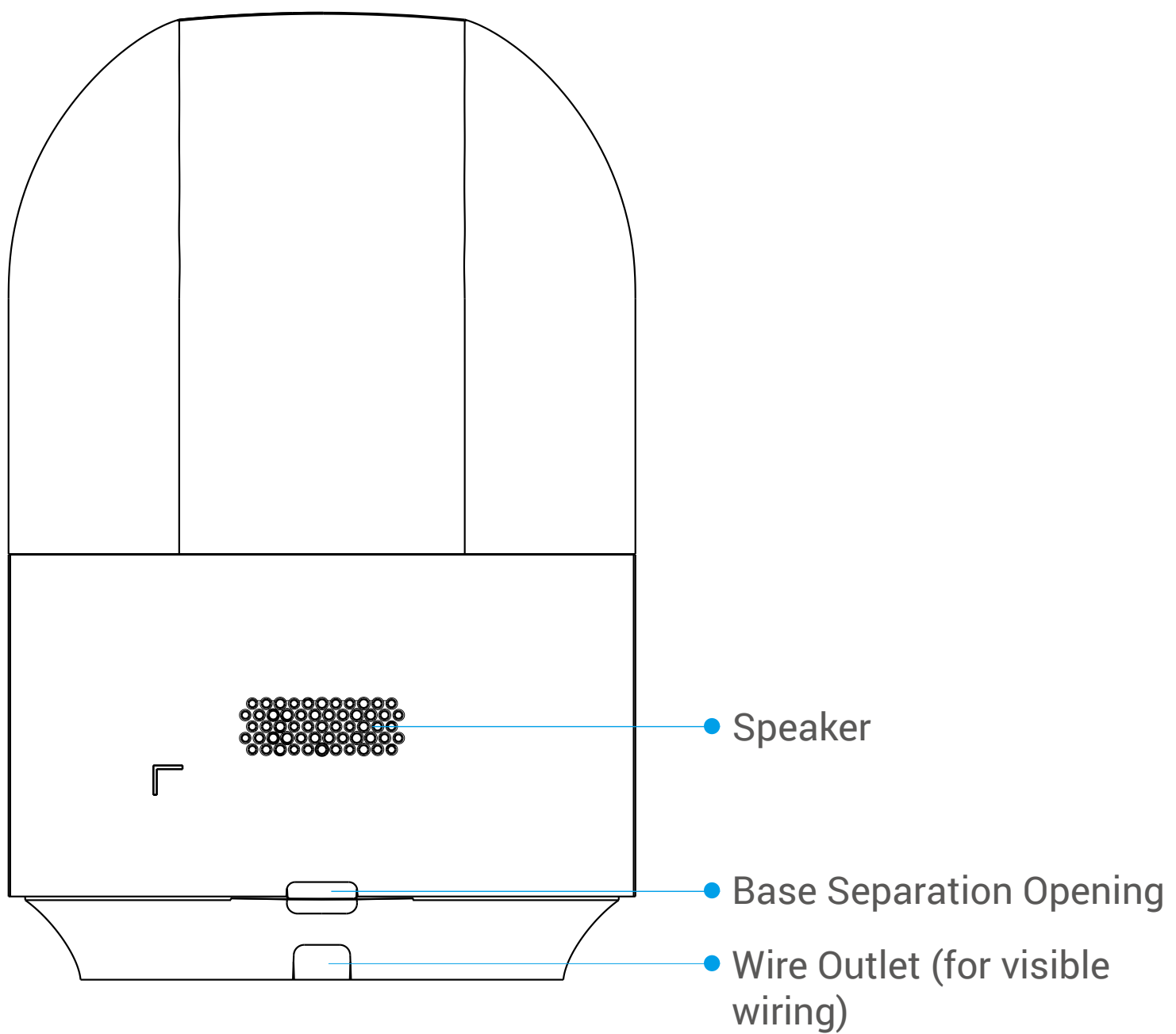

Back View

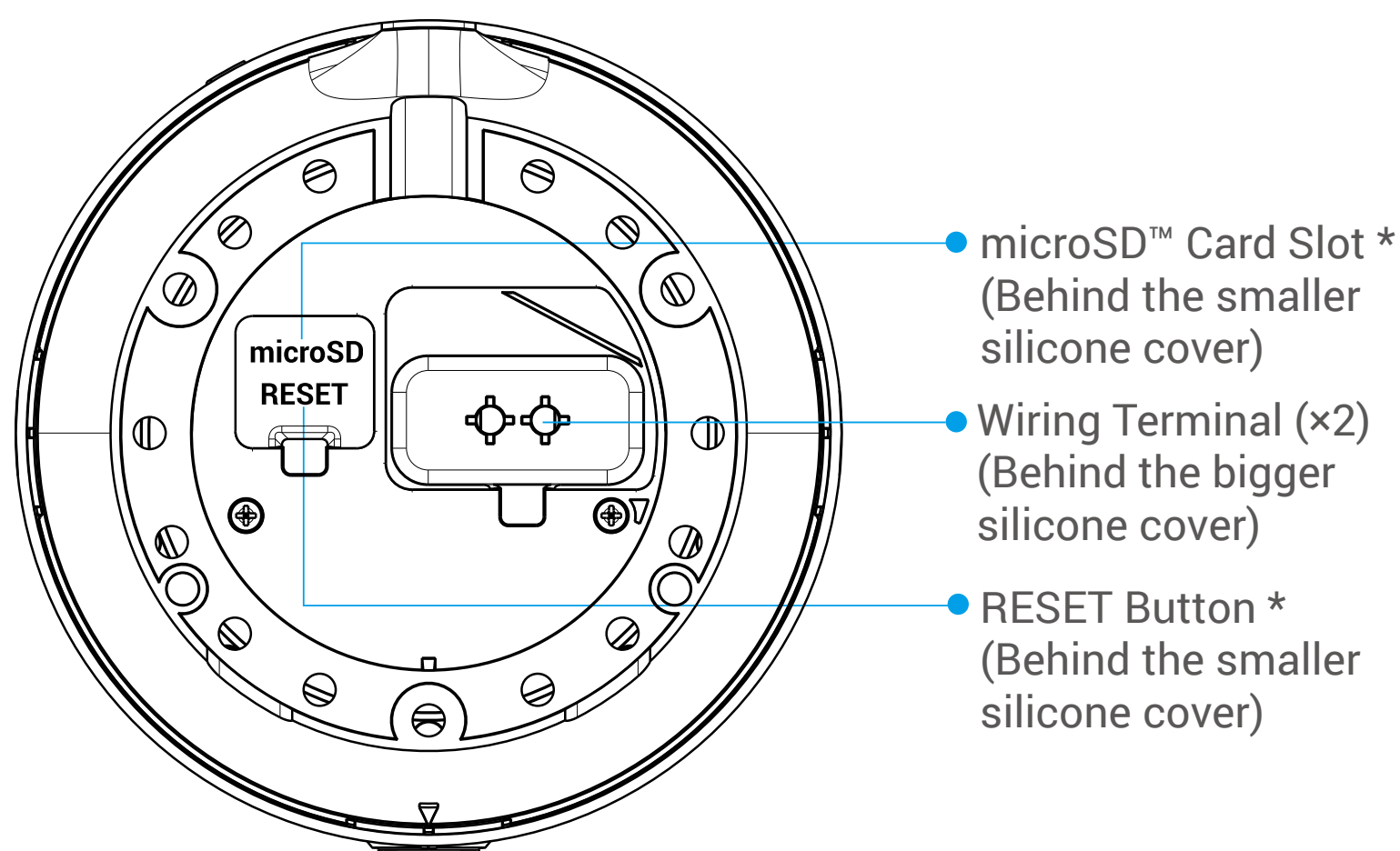

Bottom View

Name	Description
microSD™ Card Slot	Insert a microSD™ card (sold separately) into this slot. Initialize the card in the EZVIZ app before using it. Recommended compatibility: Class 10, minimum space 16GB, maximum space 512GB.
RESET Button	When the camera is working, press and hold for about 4 seconds and all parameters will be restored to default settings.

3. Installation Procedure

- It is recommended to install the alarm light camera on the same side as the primary gate.
- To ensure good live view effects, install the alarm light camera as close to the wireless repeater as possible, with no walls or metal obstructions in between.
- It is recommended to install the alarm light camera at a height of 2m. Installing the camera too high or too low may result in blind spots and affect monitoring performance.

Preparation

1. If any existing alarm light camera is installed on the pillar, remove it first. The wires can be retained for use.
2. The alarm light camera requires two wires for connection to the gate opener. If there are no wires, please drill holes and get wires ready first.
3. Take a look around the pillar and choose an ideal installation location for the alarm light camera (either on the wall or on the top of the pillar) to ensure that the camera can get a good monitoring perspective after installation.
4. It is recommended to install the alarm light camera on top of the pillar (top mounting), because the camera can get a broader monitoring perspective as well as stronger wireless performance.
5. The monitoring perspective of the alarm light camera may be affected by factors including the height of the pillar top and the top surface's angle of inclination.
6. Choose between top mounting and wall mounting based on the structure of your gate and pillars.

Top mounting

1. Choose an appropriate installation location on top of the pillar and stick the drill template (ensuring that the installation area is clean and flat).
- Make sure that the distance between the lens of the alarm light camera and the pillar edges is less than 2cm; otherwise, a blind spot in the monitoring view may occur.
 - It is recommended that the pillar should not be higher than 2.5m.

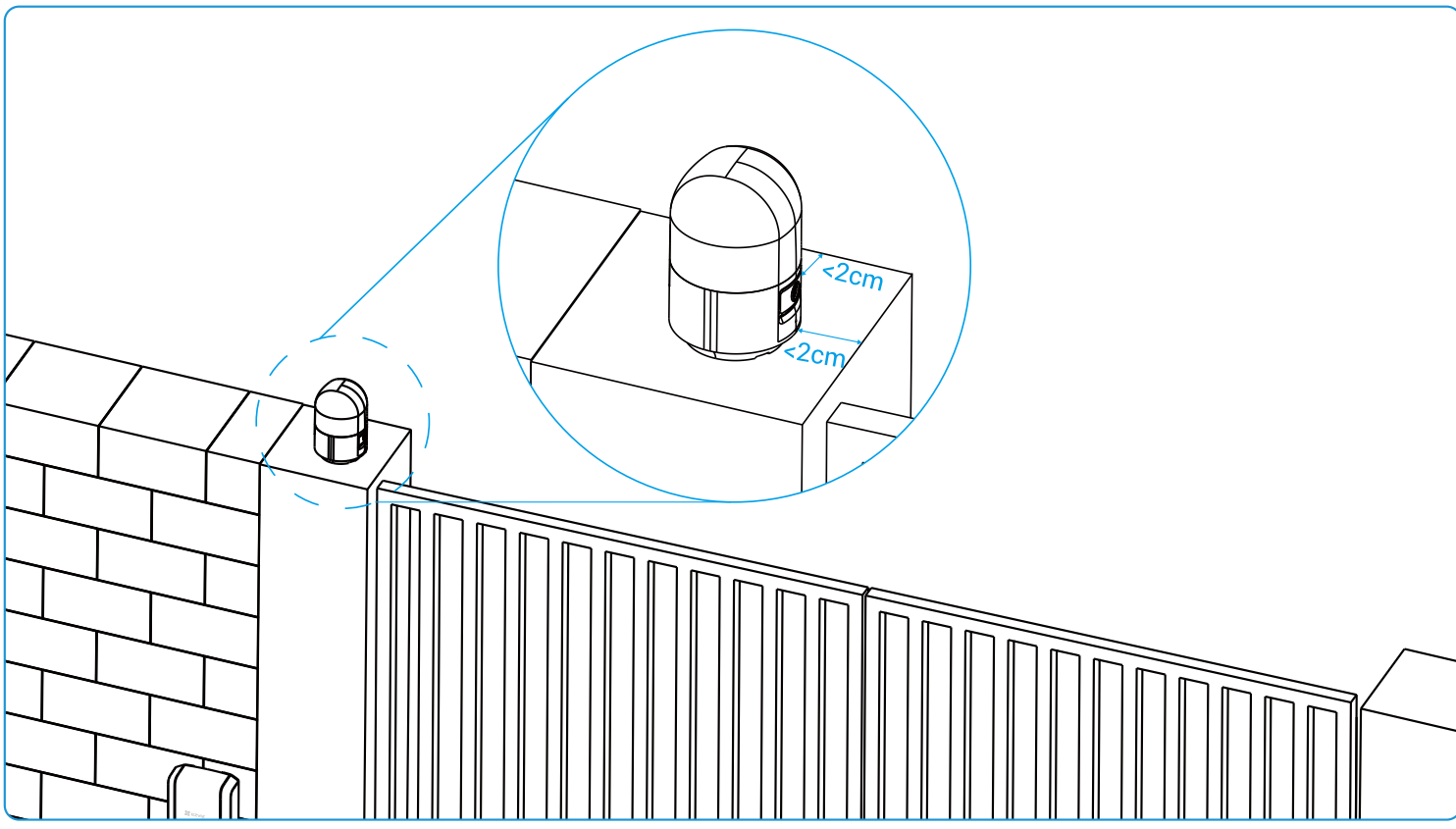

2. Use a drill bit (5.5mm diameter) to drill holes according to the three points along the circle on the drill template (drilling depth: about 25mm).

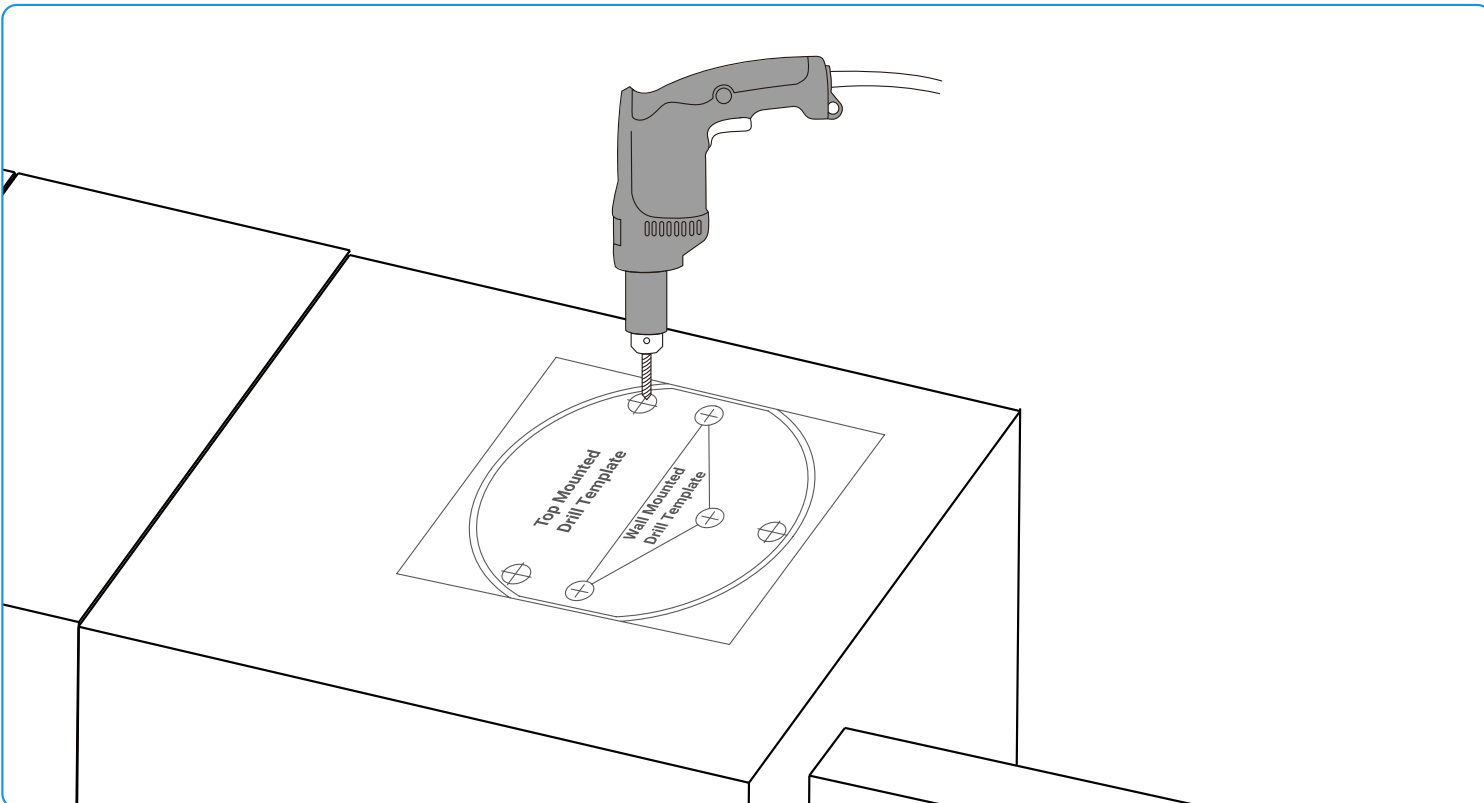

- i** Ensure that the obtuse angle of the inner triangle on the drill template points at the same direction as the lens of the alarm light camera will face (as indicated by the arrow in the figure).
3. Remove the drill template, put anchors in the holes, and hammer them just into the holes.

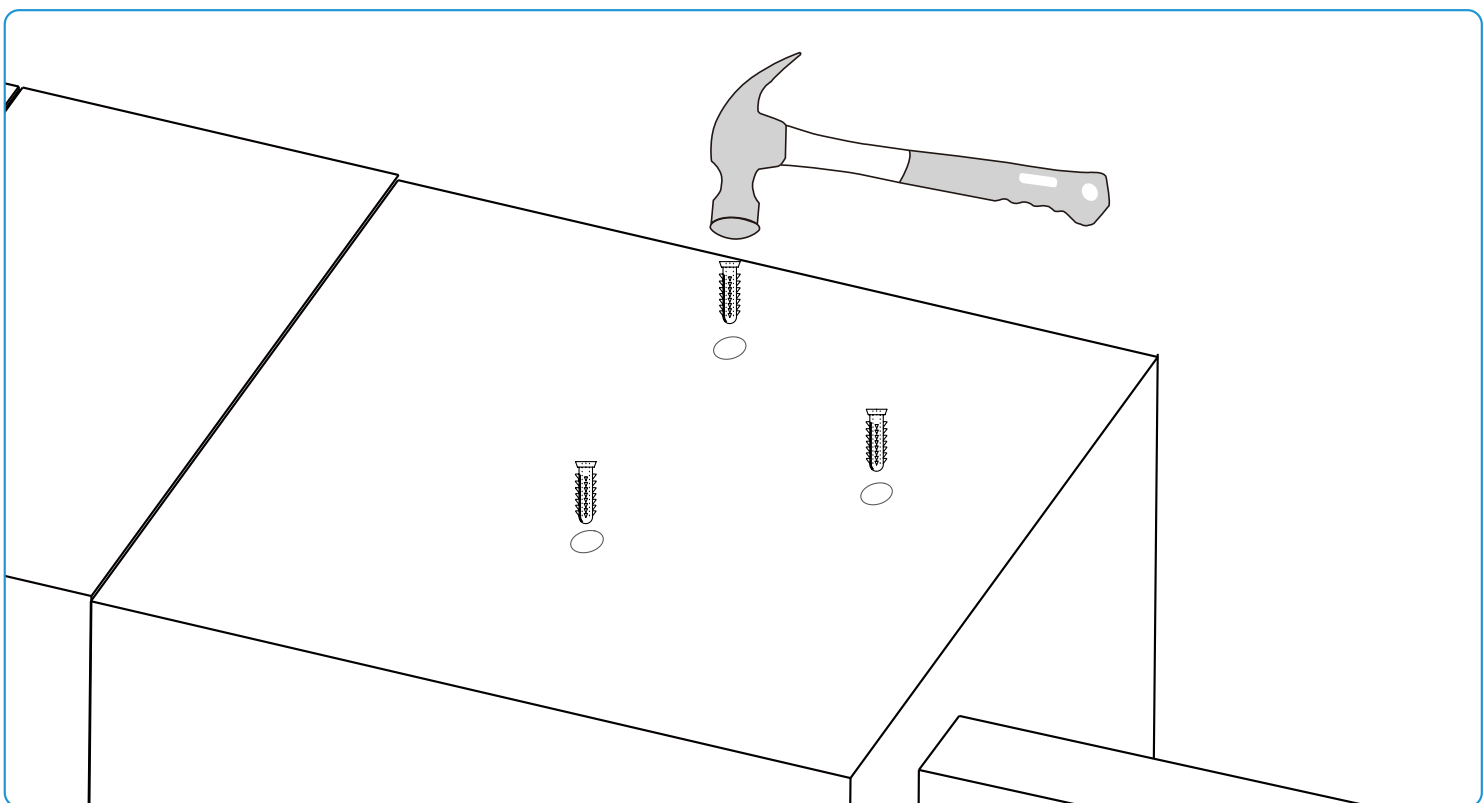

- Align the arrow sign on the camera body with the arrow assign on the camera base, and use a screwdriver to separate the base from the alarm light camera (from the base separation opening).

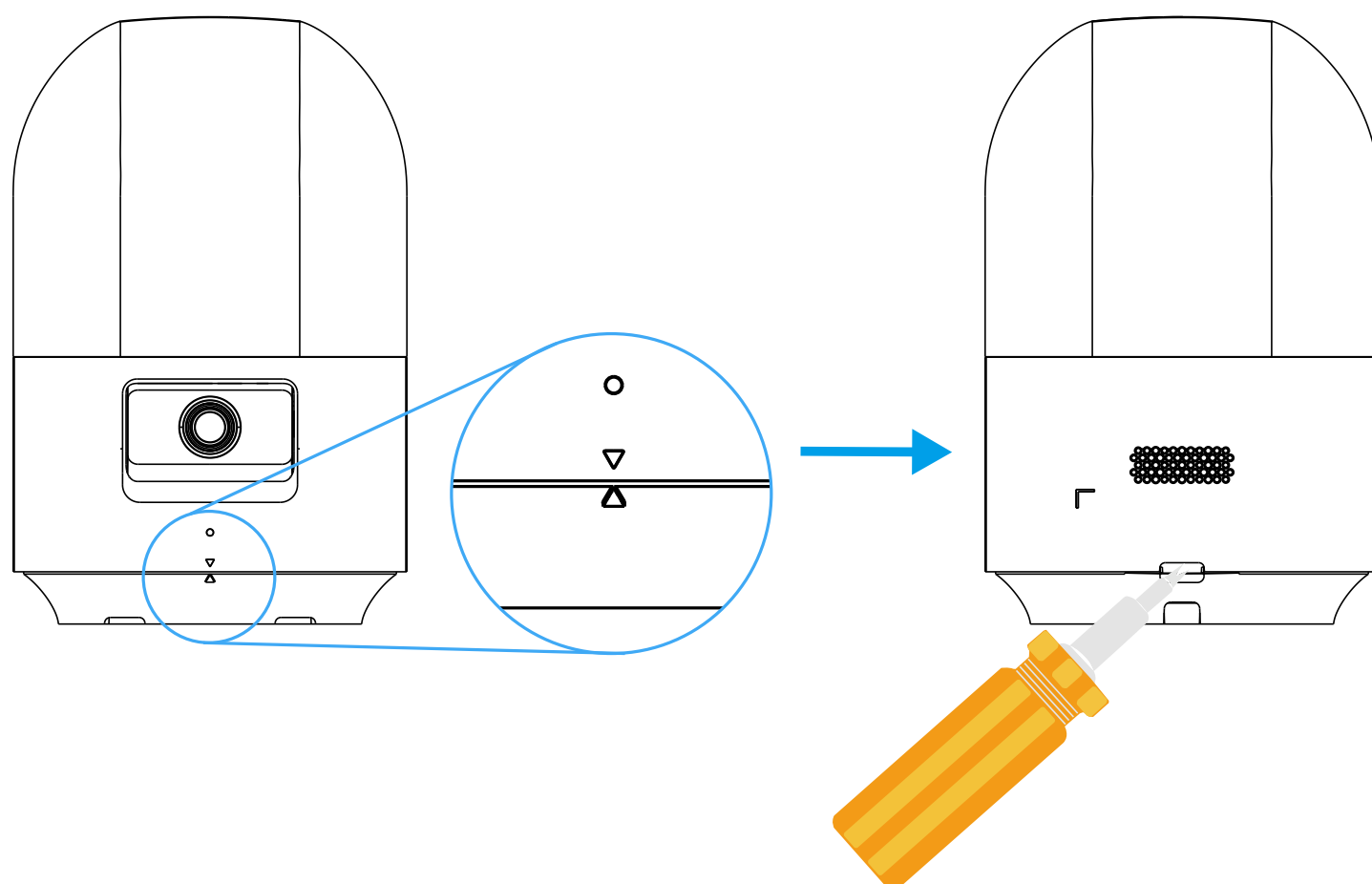

- Open the smaller silicone cover on the bottom of the camera body, insert a microSD™ card (sold separately) into the card slot, and then put the cover back on.

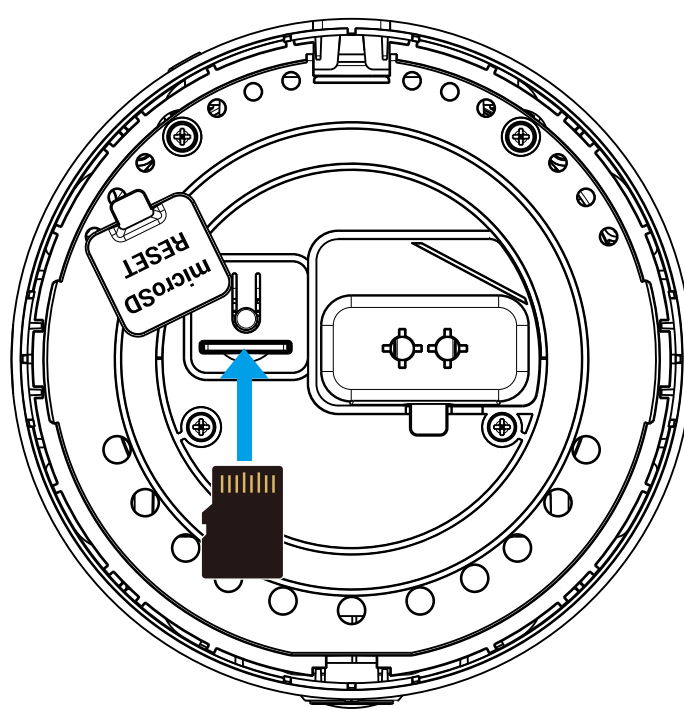

- i** After installing the microSD™ card, you should initialize the card in the EZVIZ app before using it:

 - In the EZVIZ app, tap **Storage Status** in the **Device Settings** page to check the SD card status.
 - If the memory card status displays as **Uninitialized**, tap to initialize it. The status will then change to **Normal** and then videos can be stored.
- Peel off the insulating sheath of two concealed wires for 6-10mm and guide the wires through the camera base.
- Align the three screw holes on the base with the drilled holes on top of the pillar (ensuring that the arrow sign on the base faces the gate). Use three screws to fix the base.
- Connect wires to the camera.
 - Remove the bigger silicone cover on the bottom of the camera body.
 - Use a screwdriver to loosen the two screws on the two wiring terminals.
 - Guide the concealed wires through the holes on the bigger silicone cover and connect them to the two wiring terminals.
- i** Be careful not to short-circuit the wires.

 - Use a screwdriver to tighten the screws back on the wiring terminals.
 - Put the silicone cover back on nice and tight.

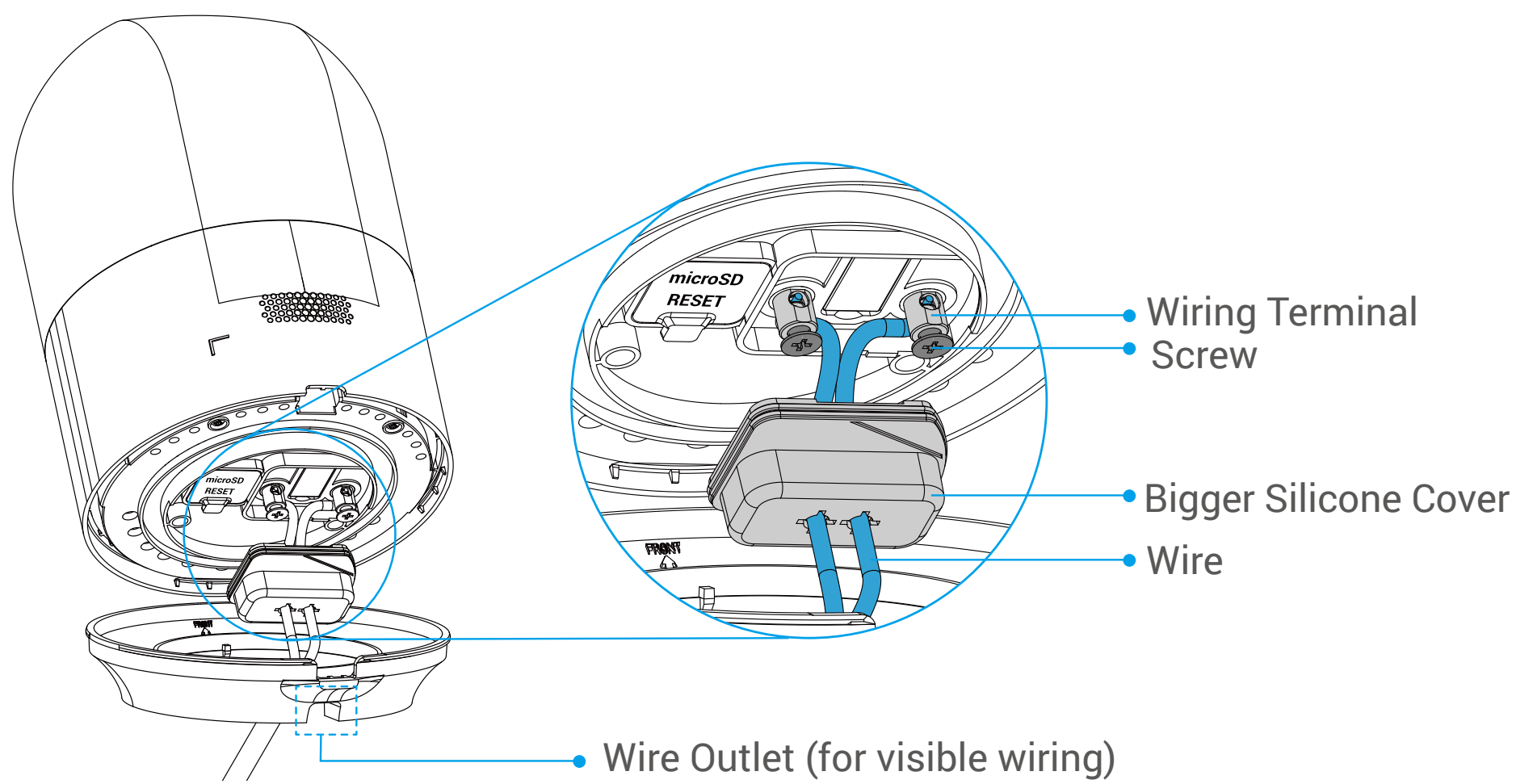

i If you are using visible wiring, guide the wires through the wire outlet after connection.

- Align the arrow sign on the camera body with the arrow on the camera base and press the camera body down to click it in place. Adjust the position of the camera body (in the horizontal direction) and the lens (in the vertical direction) to ensure a broad monitoring perspective.

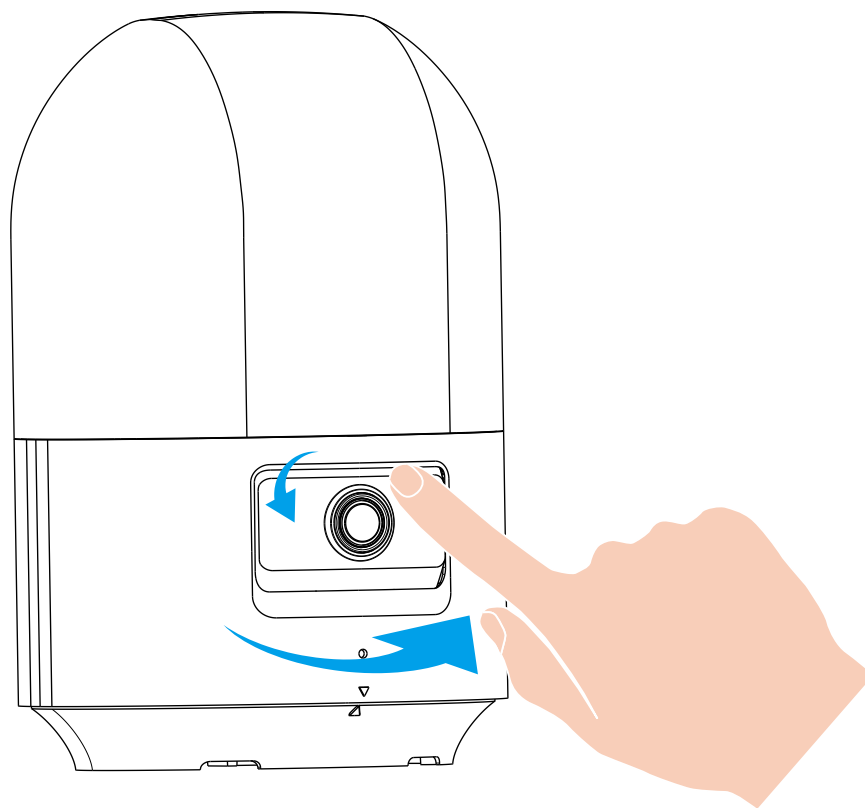

Wall Mounting

If your gate and pillars are not suitable for top mounting, you can use wall mounting.

- i**
- For wall mounting, it is recommended that the alarm light camera should be installed at a height of 1.5 to 2.5 meters.
 - Operation details of wall mounting are similar to those of top mounting and therefore are not repeated here.

- Separate the camera base from the camera body and fix the base onto the wall bracket (included in the package).
- Choose an appropriate installation location on the wall of the pillar and install the wall bracket.
- Connect wires and fix the camera body on the wall bracket.

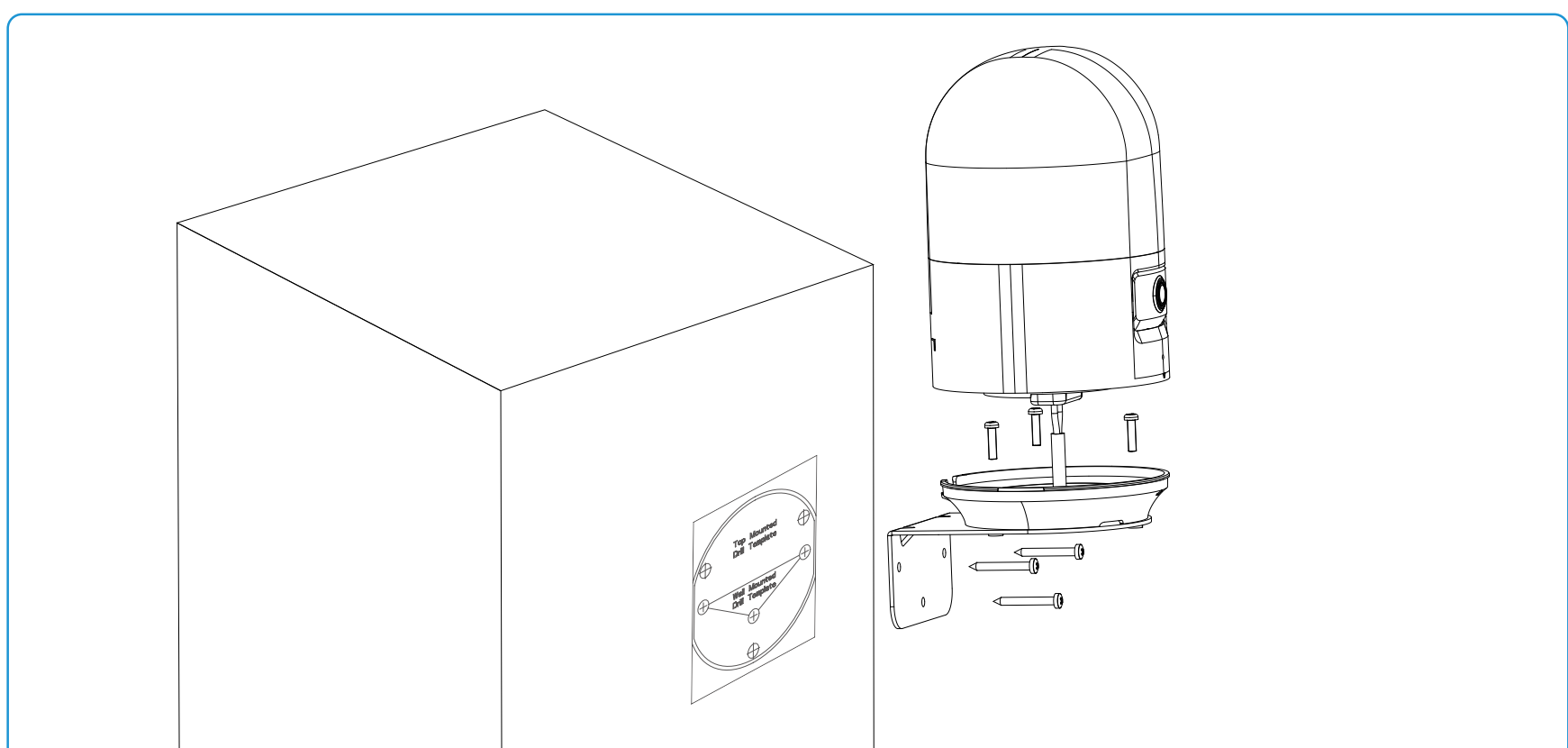

- Adjust the position of the camera body and the lens.

Wiring on the gate opener

1. Loosen the two screws on the terminals 19 and 20 ("FLASH") on the control unit.
2. Insert the two wires of the alarm light camera into the terminals 19 and 20 separately.
3. Tighten the screws back on the two terminals.
 - **Make sure that the screws are tightened properly and the wires will not fall off.**
 - **Be careful not to short-circuit the wires.**
4. Use a cable tie to fix the wires in the cable holder.

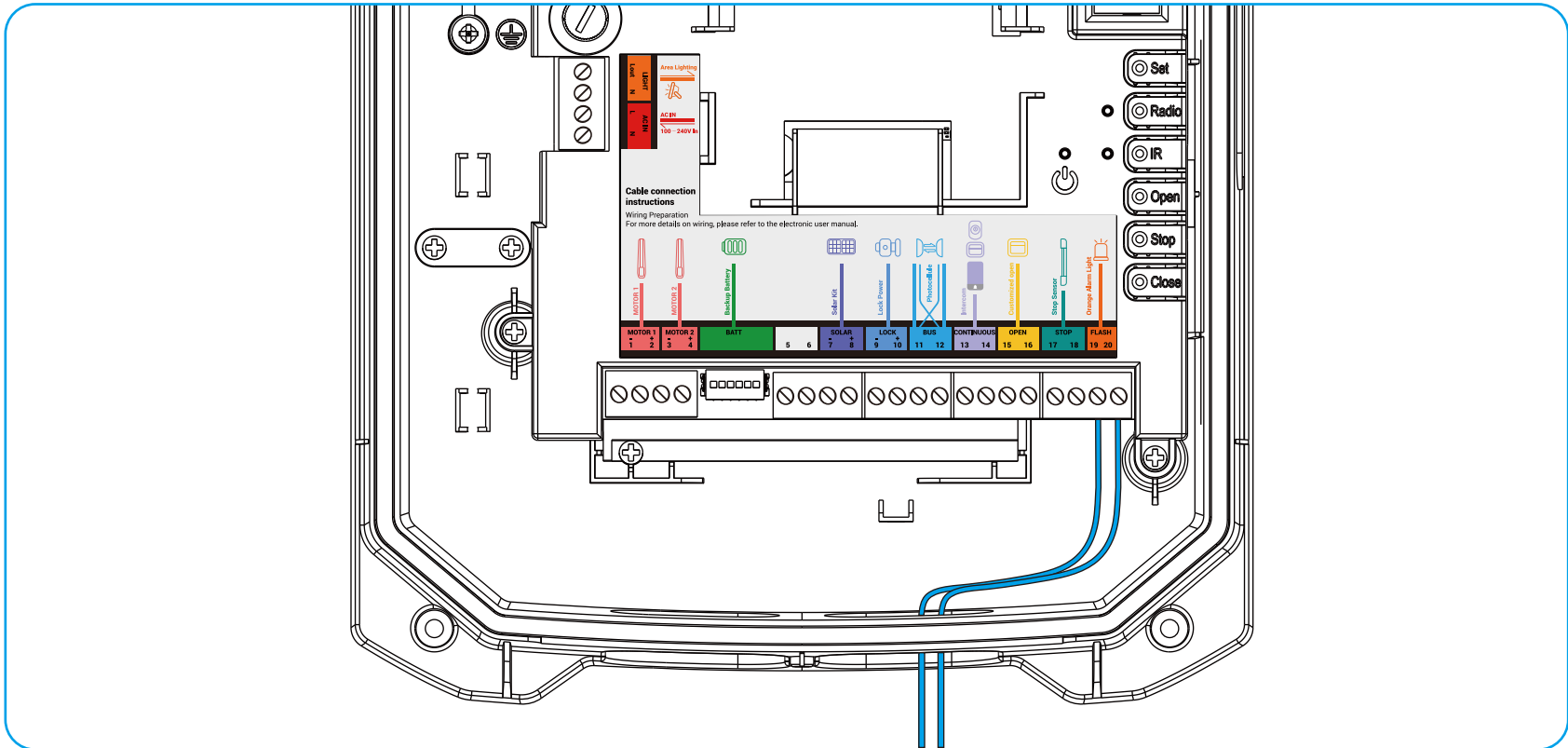

Install Other Components (Optional)

This gate opener can also be connected to the following external devices to achieve corresponding purposes.

External Device	Purpose
Intercom panel/push button/key switch	Control the gate movement in the "Open-Stop-Close" sequence.
Customized open controller	Open the gate by using external control signals. You can customize the opening mode (including fully open and only one leaf open) in the EZVIZ app.
Stop sensor/emergency stop button	Stop the gate immediately whenever the gate hits an obstacle or in emergencies.
Electric strike plate	Supply 12V DC power to an electric strike plate (without providing control signals).
Area lighting	Supply power to a spotlight.

1. Connect to Intercom Panel, Push Button or Key Switch

If you have any intercom panel, push button, or key switch, you can connect them to this gate opener so that you can control the gate movement by using these devices.

After successful connection, each time the gate opener receives a control signal from the connected intercom panel, push button, or key switch, the gate opener controls the gate in the "Open-Stop-Close" sequence.

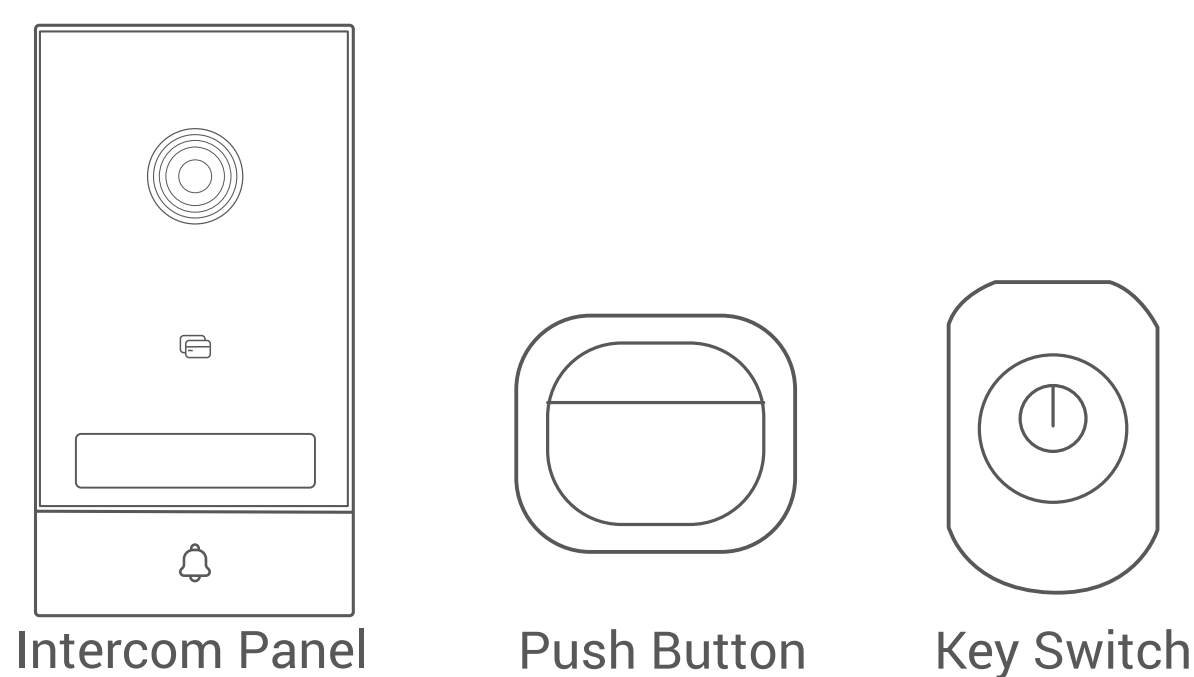

Connect the wires of your device to terminals 13 and 14 ("CONTINUOUS") on the control unit.

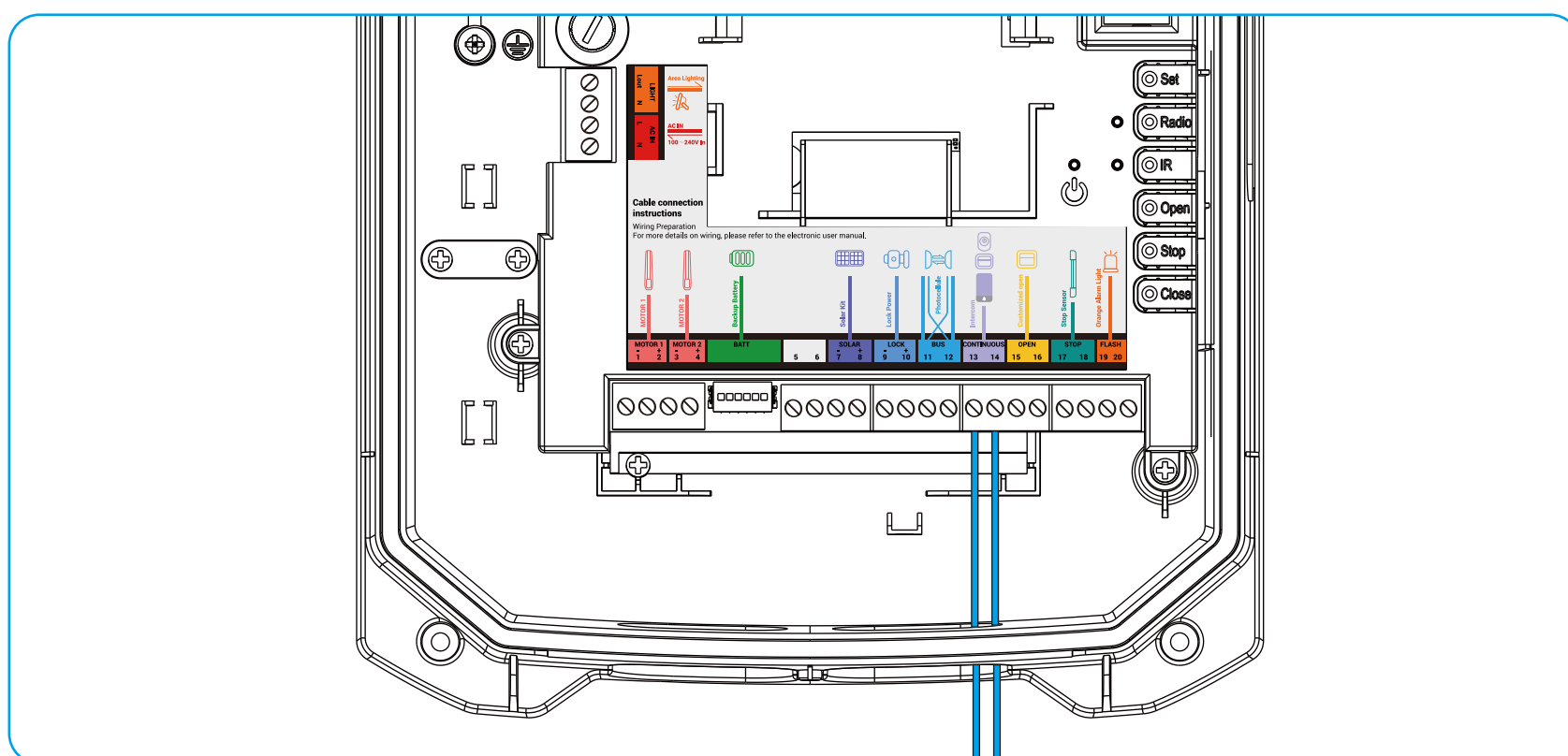

- The "CONTINUOUS" terminals are polarity-insensitive.
- Multiple devices can be connected to the "CONTINUOUS" terminals at the same time.

2. Connect to Customized Open Controller

In certain scenarios you may need more customized gate opening, such as fully open and only one leaf open. In these cases, you can connect a customized open controller to this gate opener and select a customized opening mode as you need in the EZVIZ app to realize customized gate opening.

1. Connect the wires of your customized open controller to terminals 15 and 16 ("OPEN") on the control unit.

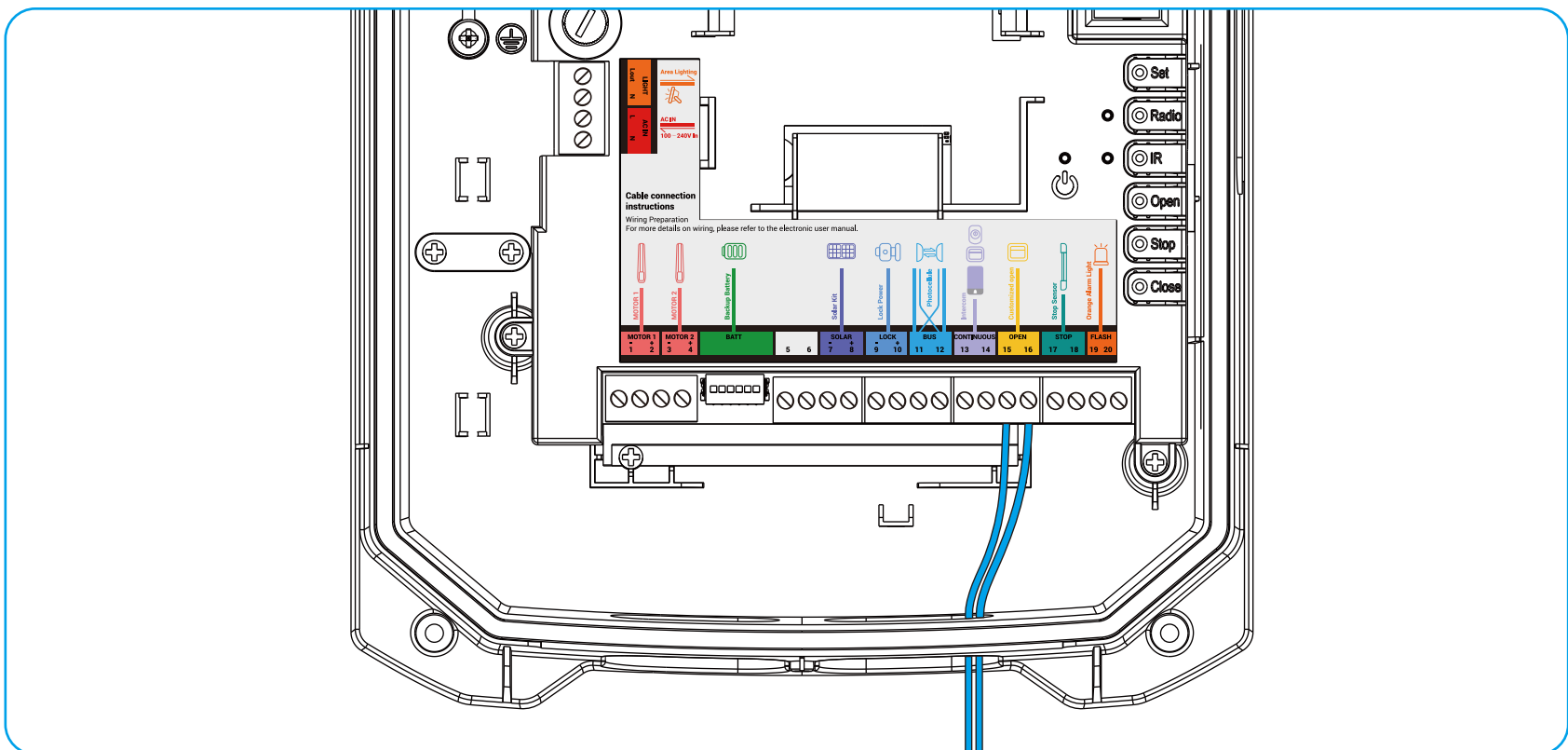

2. In the EZVIZ app, go to the gate opener settings page, select "Gate Opening/Closing Settings > Customize Button Setting".
3. Select a customized opening mode as needed.

- The "OPEN" terminals are polarity-insensitive.
- Multiple devices can be connected to the "OPEN" terminals at the same time.
- After successful connection, each time the gate opener receives a control signal from the connected customized open controller, the gate opener opens the gate immediately.

3. Connect to Stop Sensor or Emergency Stop Button

For safety considerations, it is recommended to use a stop sensor or an emergency stop button to prevent gate movement from causing personal injuries.

- If your force limiter on the gate frame does not have an embedded stop sensor, you're advised to install a stop sensor on the force limiter (as shown in the figure below) and connect the wires of the stop sensor to the terminals 17 and 18 ("STOP") on the control unit.

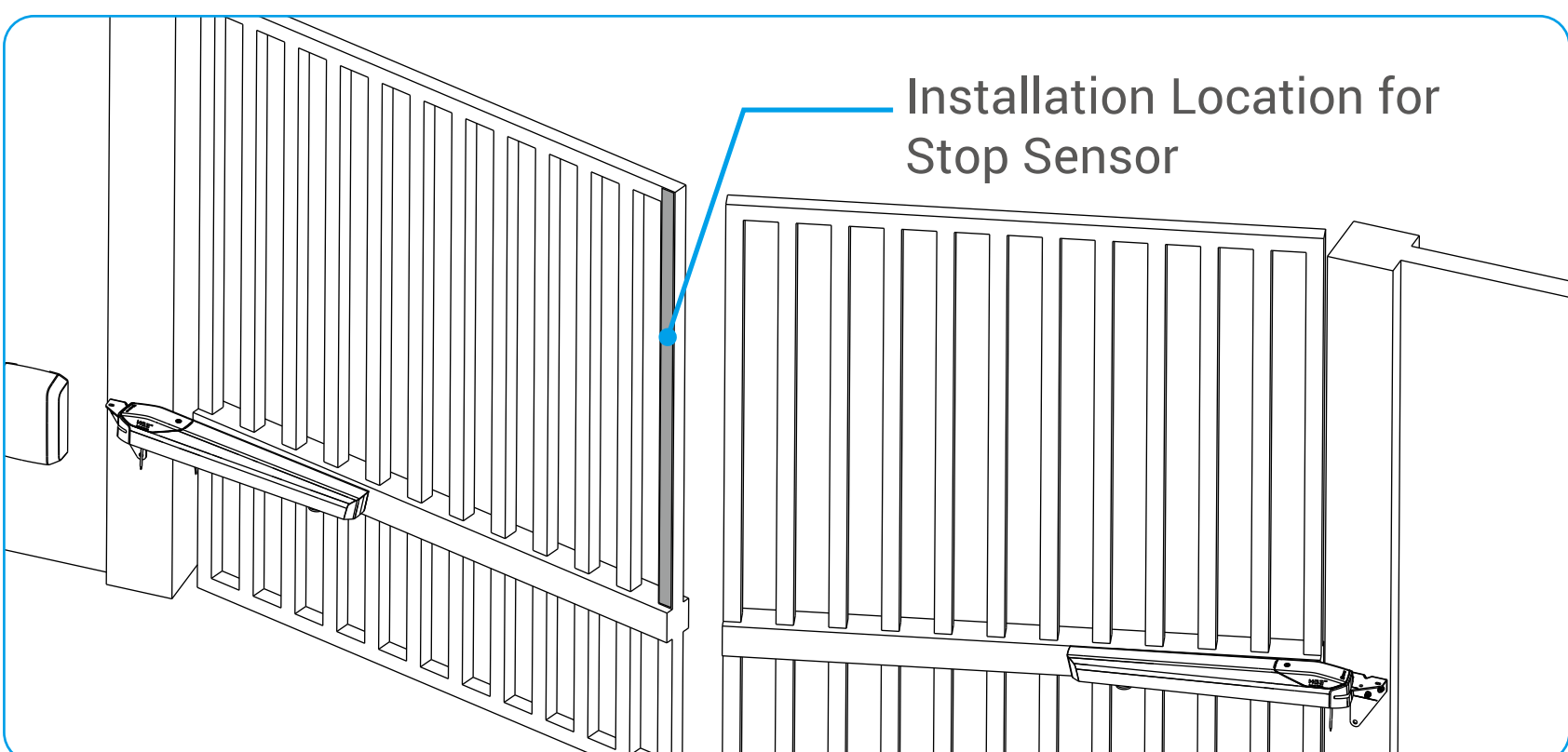

- If your force limiter on the gate frame already has an embedded stop sensor, you only need to connect the wires of the stop sensor to the terminals 17 and 18 ("STOP") on the control unit.

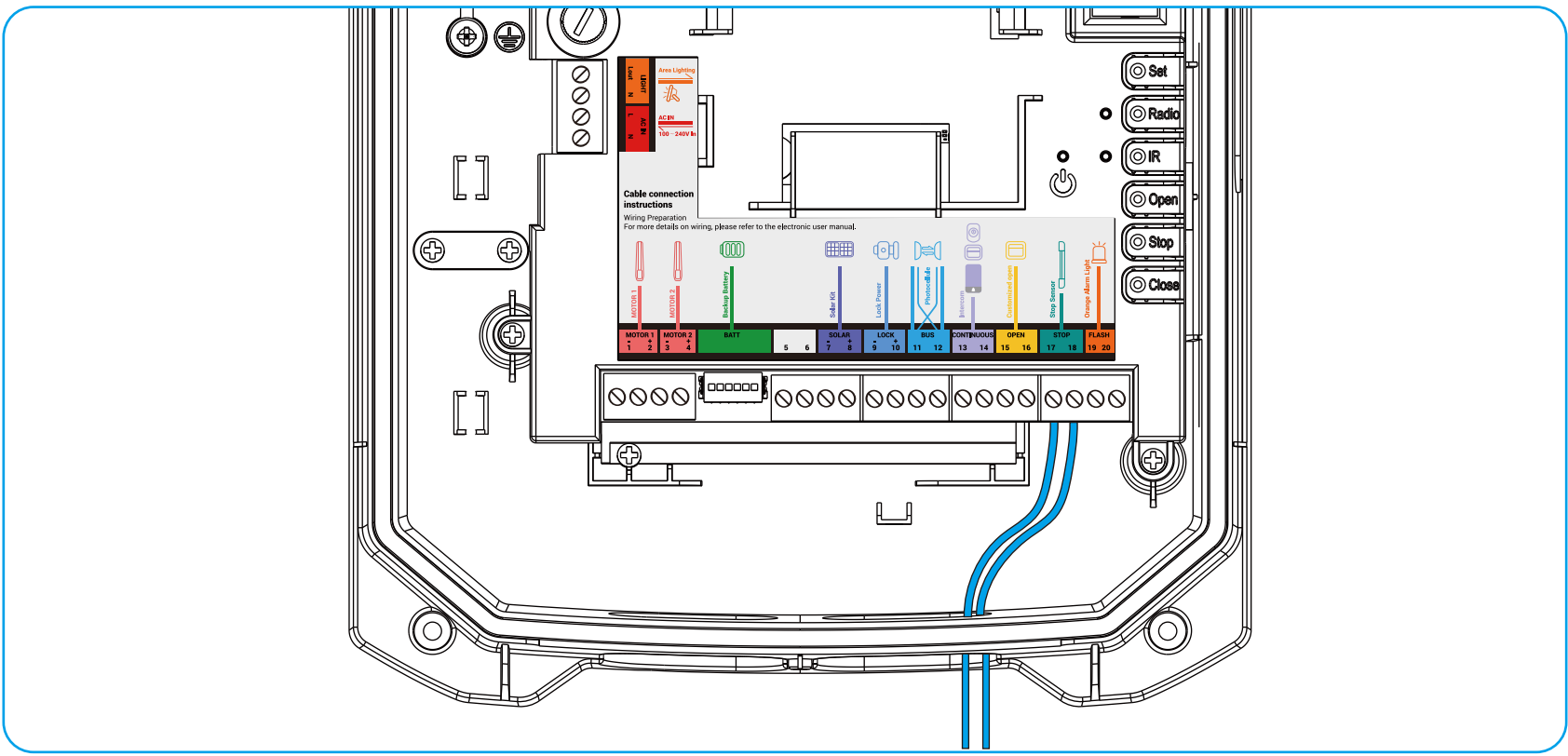

Without a stop sensor, the gate opener's anti-collision protection is achieved only by the resistance rebound mechanism of the gate opener itself.

With connection to a stop sensor, each time when the stop sensor detects any resistance, it sends a signal to the gate opener so that the gate opener stops the gate immediately, thus realizing more sensitive and quick anti-collision protection to better prevent from causing personal injuries.

- You can also connect an emergency stop button to the "STOP" terminals, so that in an emergency that might involve danger, you can press the emergency stop button to stop the gate immediately.

- **The "STOP" terminals are polarity-insensitive.**
- **Multiple devices can be connected to the "STOP" terminals at the same time.**
- **After successful connection, each time the gate opener receives a signal from the connected stop sensor, or emergency stop button, the gate opener stops the gate immediately.**

4. Connect to Electric Strike Plate

If you have an electric strike plate connected to your intercom panel, the power consumption of the electric strike plate may be large and the intercom panel may not be able to provide enough power to the strike plate. In this case, you can connect the electric strike plate to the gate opener, so that the gate opener can serve as a power supply to provide 12V DC power for the electric strike plate (as shown in the figure below).

Note that the gate opener only serves as a power supply and does not send control signals to the electric strike plate.

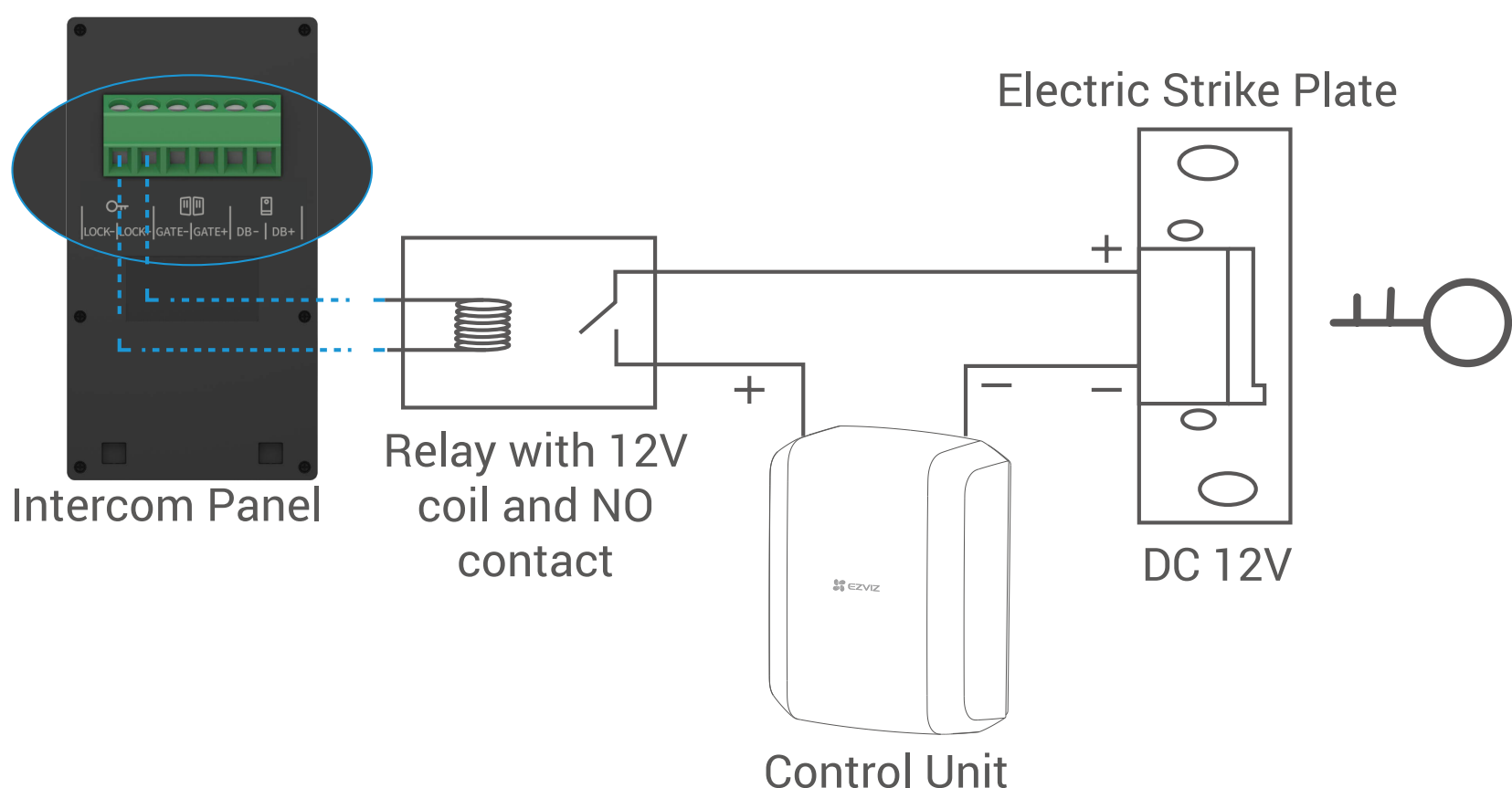

Connect the wires of your electric strike plate to terminals 9 and 10 ("LOCK") on the gate opener. Make sure to connect the positive wire to the terminal 10 and the negative wire to the terminal 9.

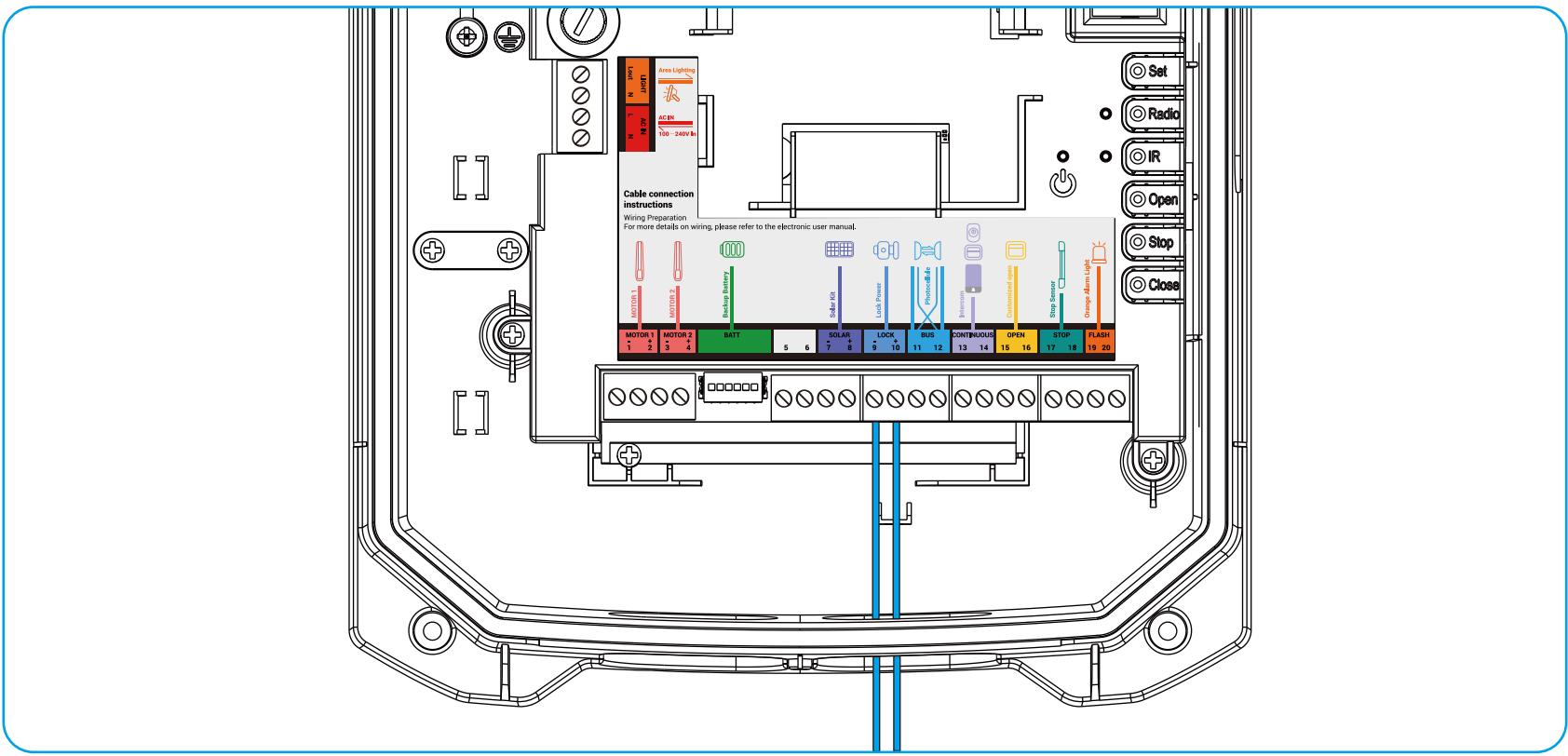

5. Connect to Area Lighting

The gate opener can also serve as a power supply to provide 100-240V AC power for your spotlight.

Connect the live wire of your spotlight to the "Lout" interface and the neutral wire to the "N" interface on the gate opener.



- i** It is recommended that the power of the connected spotlight should not exceed 100 watts.

After area lighting is connected, you can select how to turn on or off the spotlight. Go to the settings page of the gate opener (refer to ["2.2 Gate Opener Settings"](#)) and tap "Spotlight Setting":

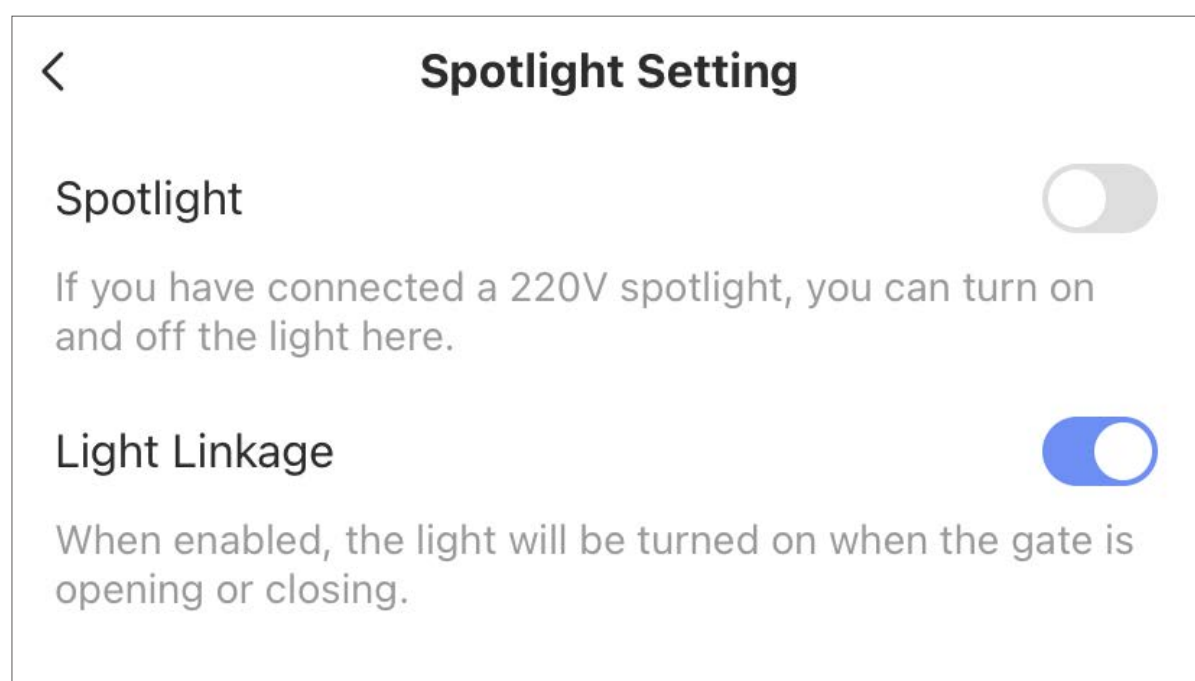

- **Spotlight:** You can manually turn on or off the light here.
- **Light Linkage** (visible only when the "Spotlight" switch is off): When the spotlight is turned off, you can also turn on "Light Linkage" so that the light will be automatically turned on when the gate is opening or closing. (The light will be automatically turned off 30 seconds after the gate stops.)

Preparatory Configuration

1. Wire Check

Check all wires according to the two instructional labels (as shown below) on the gate opener. Make sure there are no short-circuits.

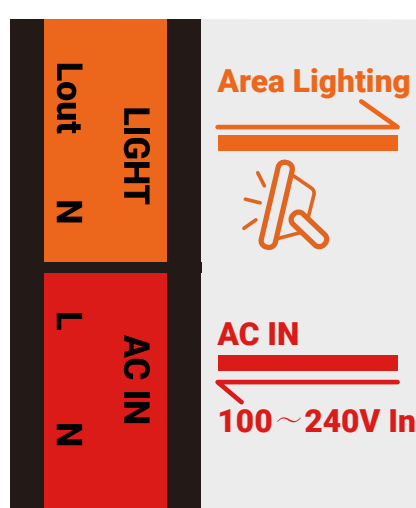
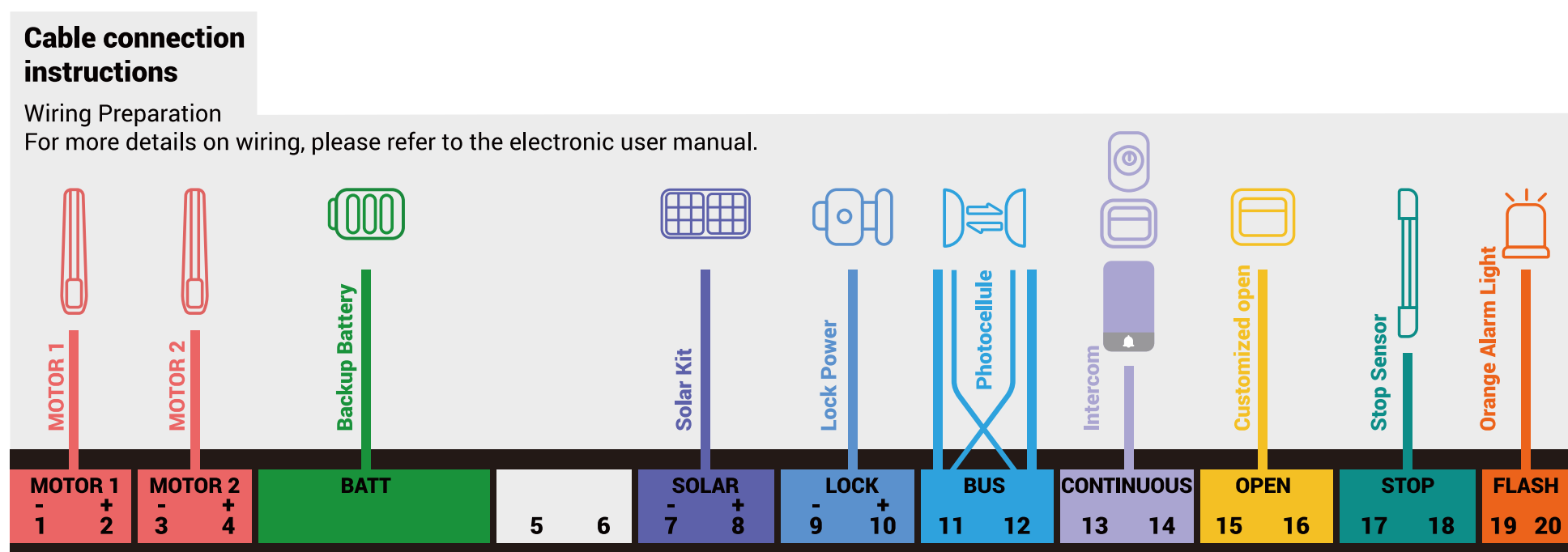

2. Power On the Gate Opener

1. Close the circuit breaker used for the gate opener.

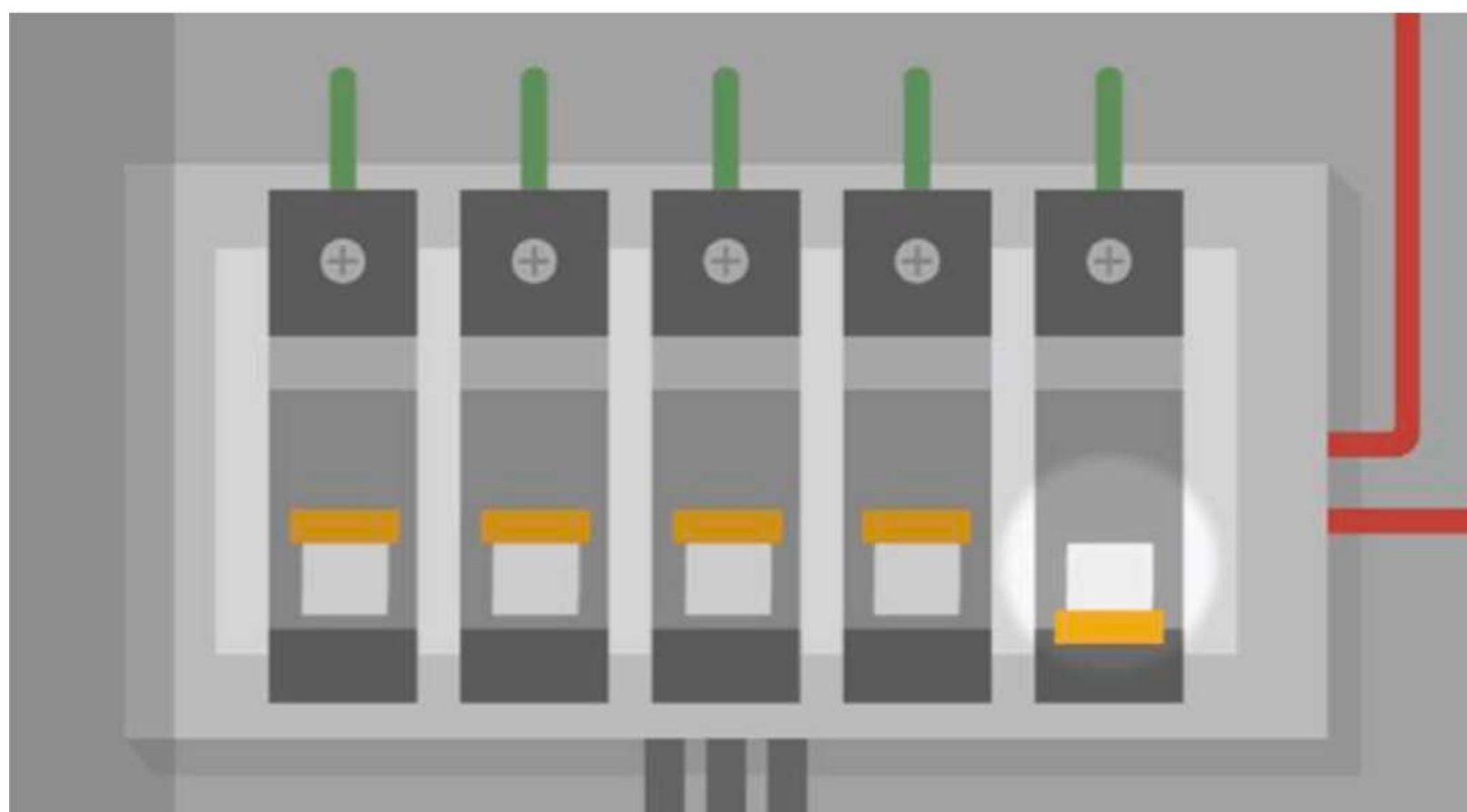

2. Check the following items to ensure that the gate opener has been successfully powered on.

i Before power-on, ensure that your wireless repeater has been added to the EZVIZ app and remains online, and terminal authorization is complete.

- The power indicator becomes solid red.
- The digital display tube lights up and shows "00", indicating the gate opener is starting up. After about 20 seconds, the digital display tube shows "--", indicating that the startup has finished.

3. After power-on, the gate opener starts a self-test and is then automatically added to your EZVIZ account (which may take a few minutes) based on communication with the wireless repeater. You can follow the wizard in the EZVIZ app to complete preparatory configuration.

3. Add the Remote Controller

Basics of the remote controller

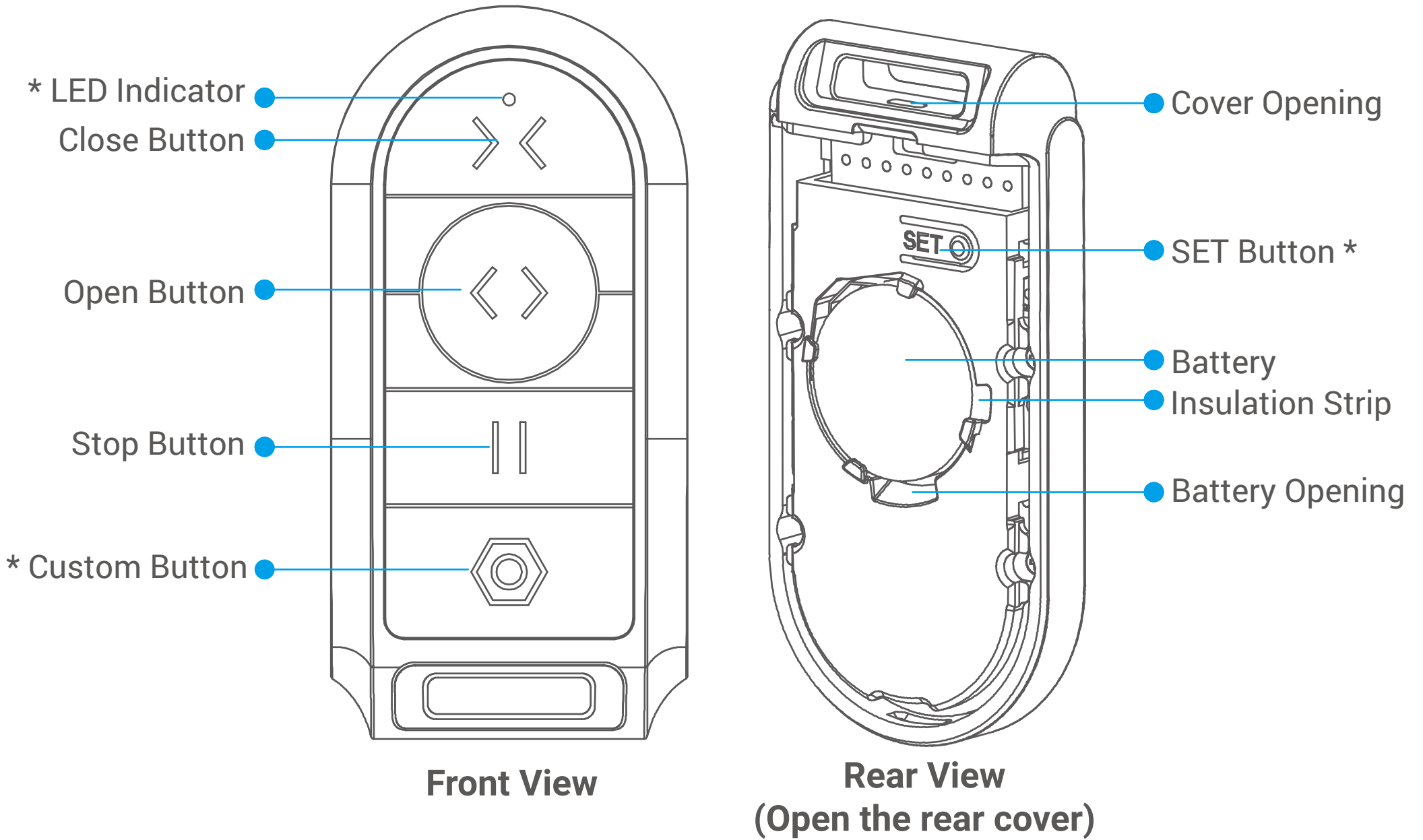

Name	Description
LED Indicator	Fast-flashing red: Remote controller ready for pairing.
Custom Button	After pairing the remote controller with the gate opener, customize the function of this button in the gate opener's setting page in the EZVIZ App (Path: Settings > Lock/Unlock Settings > Custom Button Setting).
SET Button	Press and hold for 2 seconds: Remote controller ready for pairing.

Pairing with the gate opener

i Before pairing the remote controller with the gate opener, please ensure that the gate opener has been added to the EZVIZ app.

1. Insert the pin (provided in the package) into the cover opening and press inward to unlock the cover.
2. Insert the pin into the gap between the remote controller and the cover and press down the pin to pry off the cover.

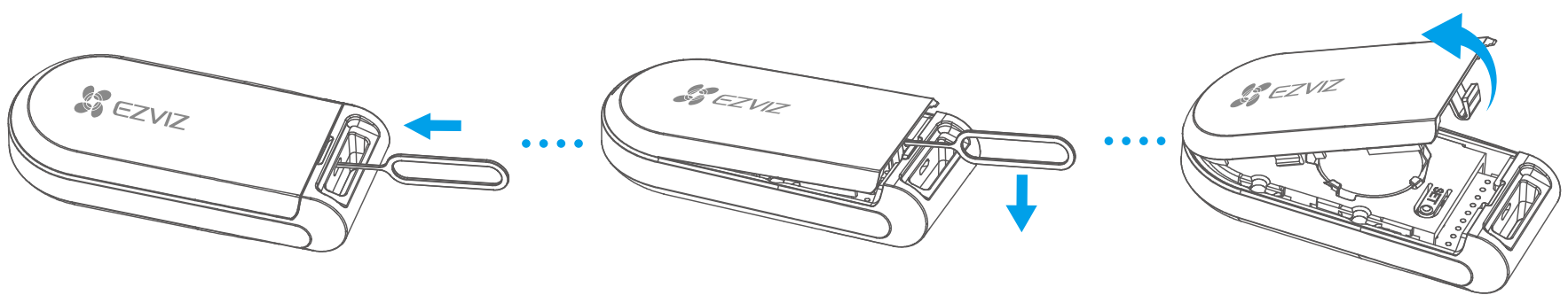

3. Remove the battery insulation strip.

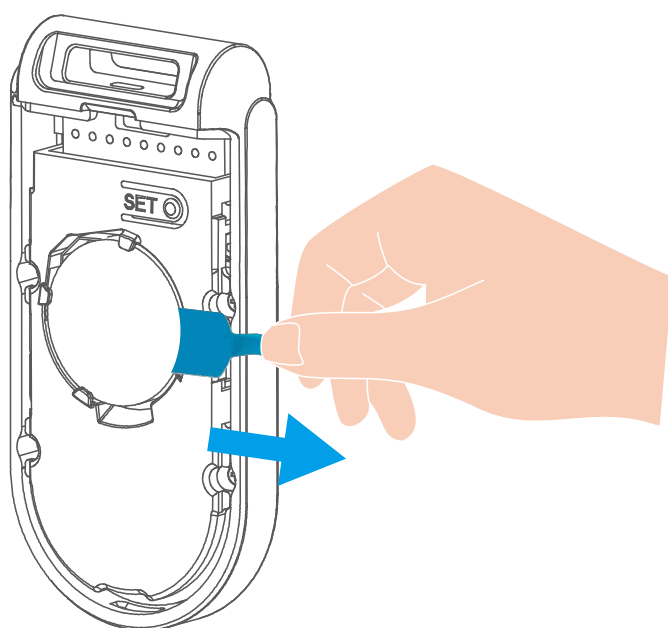

4. Pair the remote controller with the gate opener by using any of the following methods:

- i** It is recommended that the distance between the remote controller and the gate opener should be within 30 meters, with no more than 2 walls in between.
- Up to 8 remote controllers can be paired with one gate opener.

Method 1 (recommended):

- a. Follow the wizard in the EZVIZ app and tap "Start Adding".
- b. Within 60 seconds, press and hold the "SET" button on the remote controller for 2 seconds until the LED indicator of the remote controller becomes fast-flashing red.

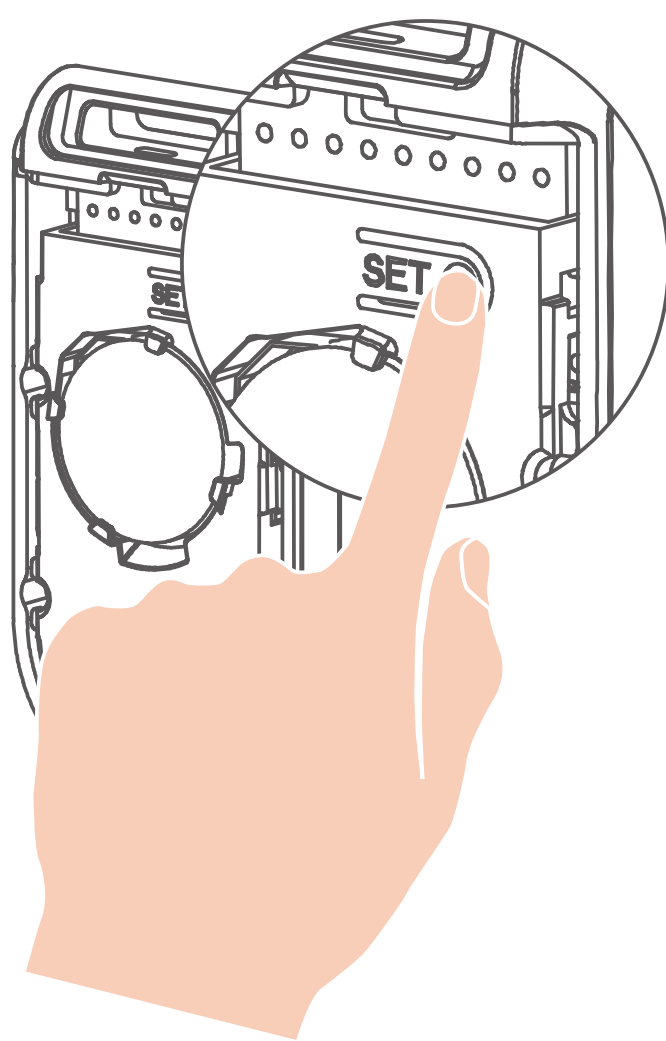
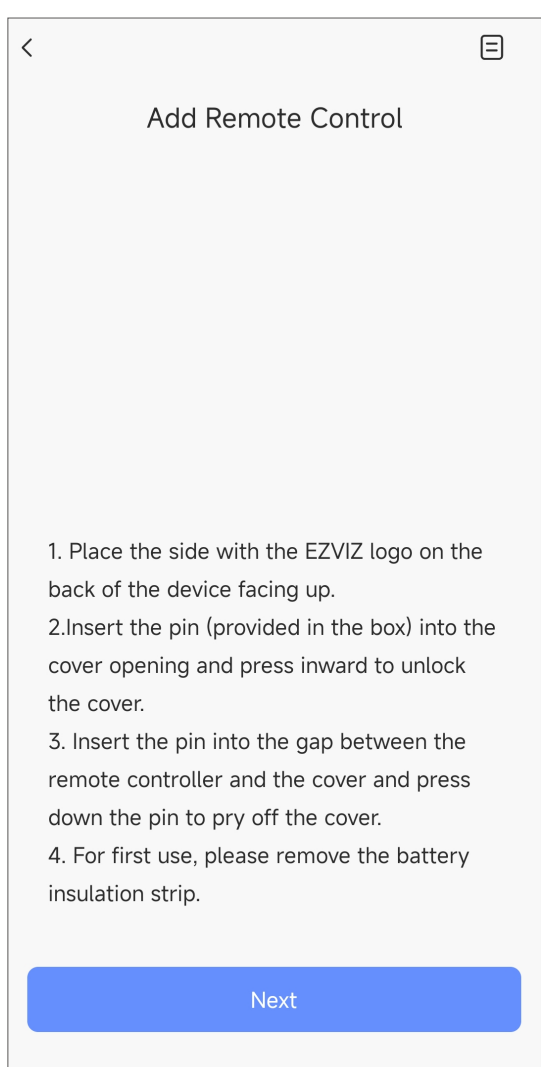

Method 2:

- a. Press and hold the "SET" button on the remote controller for 2 seconds until the LED indicator of the remote controller becomes fast-flashing red.
- b. Press the "Radio" button on the gate opener.

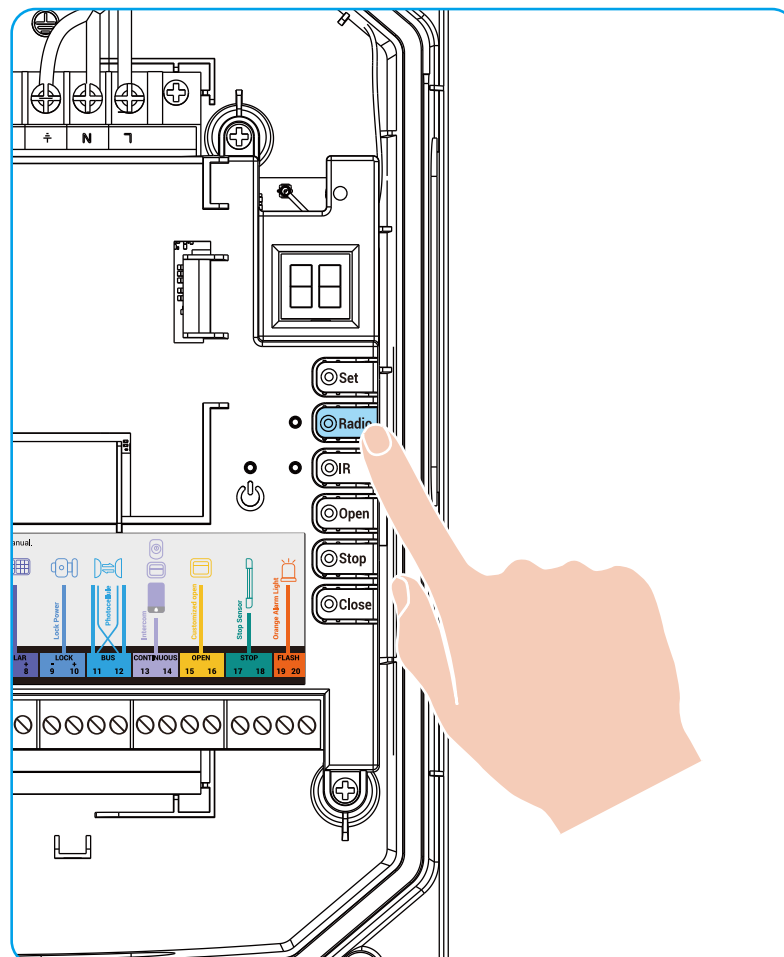
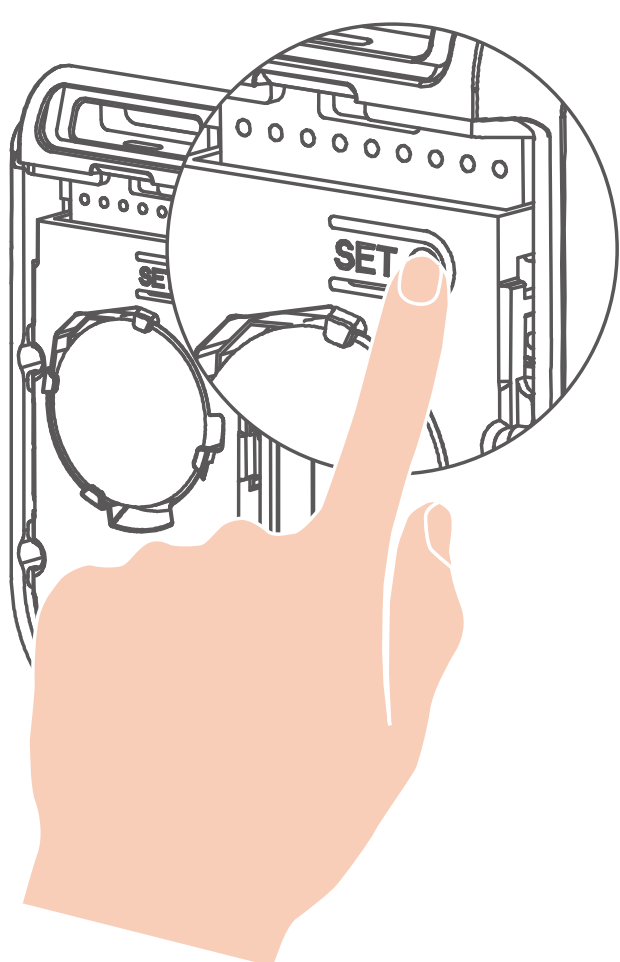

- 5. When the LED indicator of the remote controller changes from solid red to fast-flashing red and then dimmed, it indicates that the remote controller has been successfully paired with the gate opener.

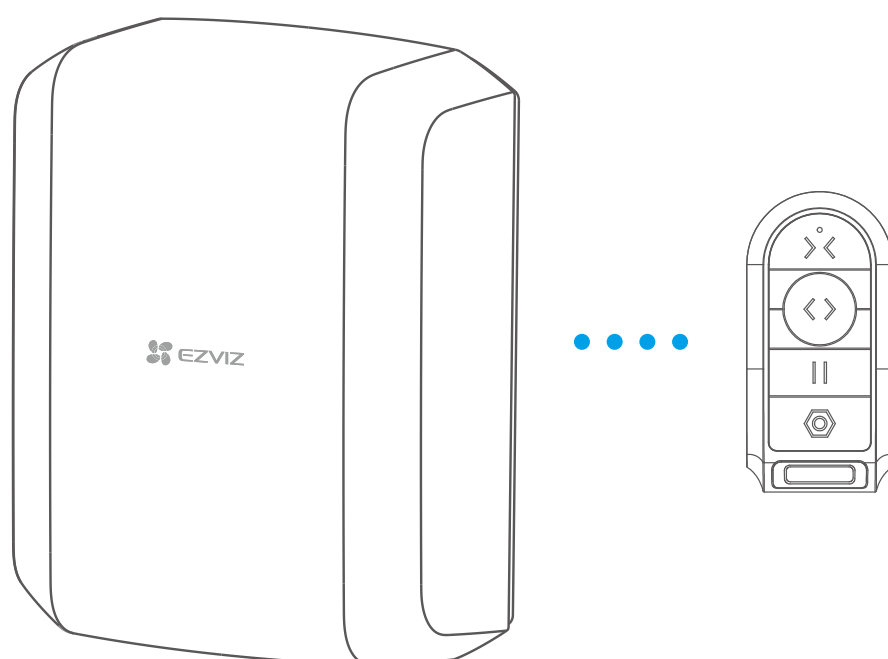

Battery Replacement

i Use CR2032 batteries for replacement.

When the range of the remote controller decreases significantly and the red light

is dim, this means that the remote controller battery will soon be completely exhausted.

1. Open the cover according to step 1 to step 2 of "Pairing with the gate opener".
2. Insert the pin into the battery opening and press down the pin to pry off the battery.
3. Install a new battery.
4. Place the cover back on the remote controller.

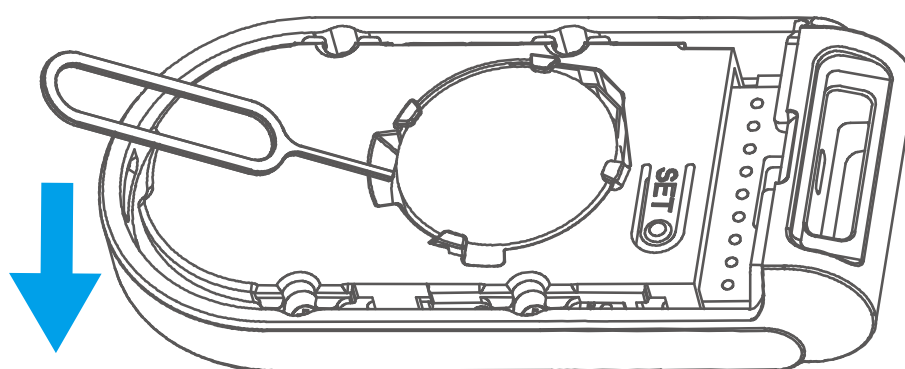

4. Test the Photocellules

1. Press the "IR" button on the control unit.

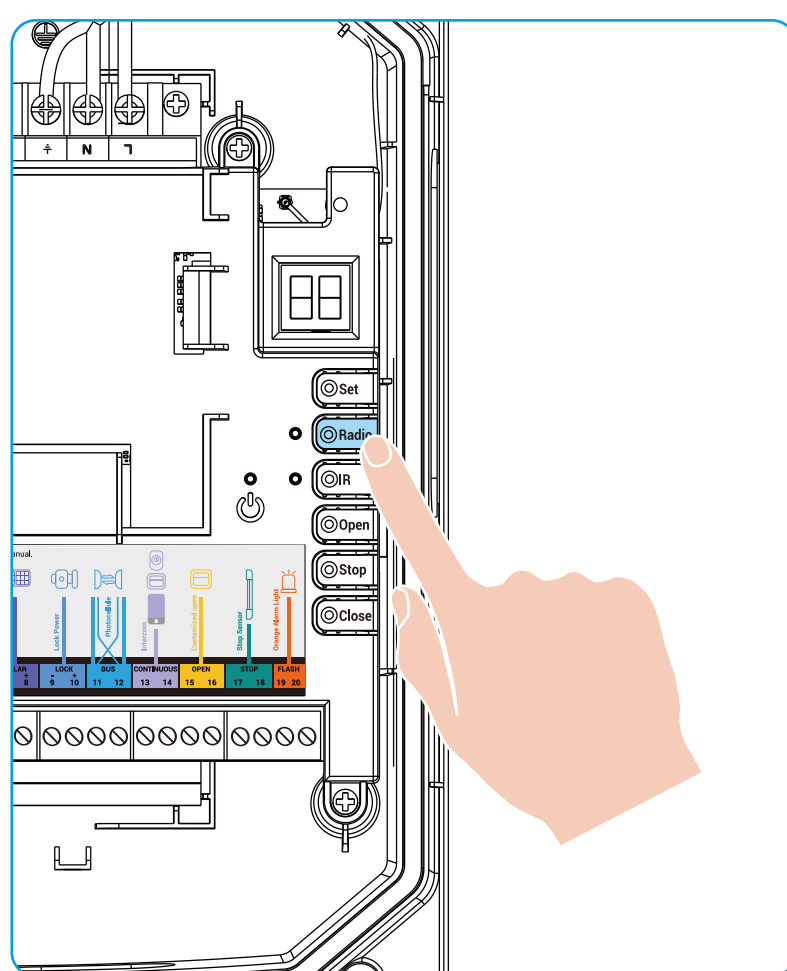

2. The IR indicator becomes solid red, indicating that the gate opener has entered the infrared self-testing mode.
3. Put an obstacle between the photocellules to check that the IR indicator becomes slow-flashing red.

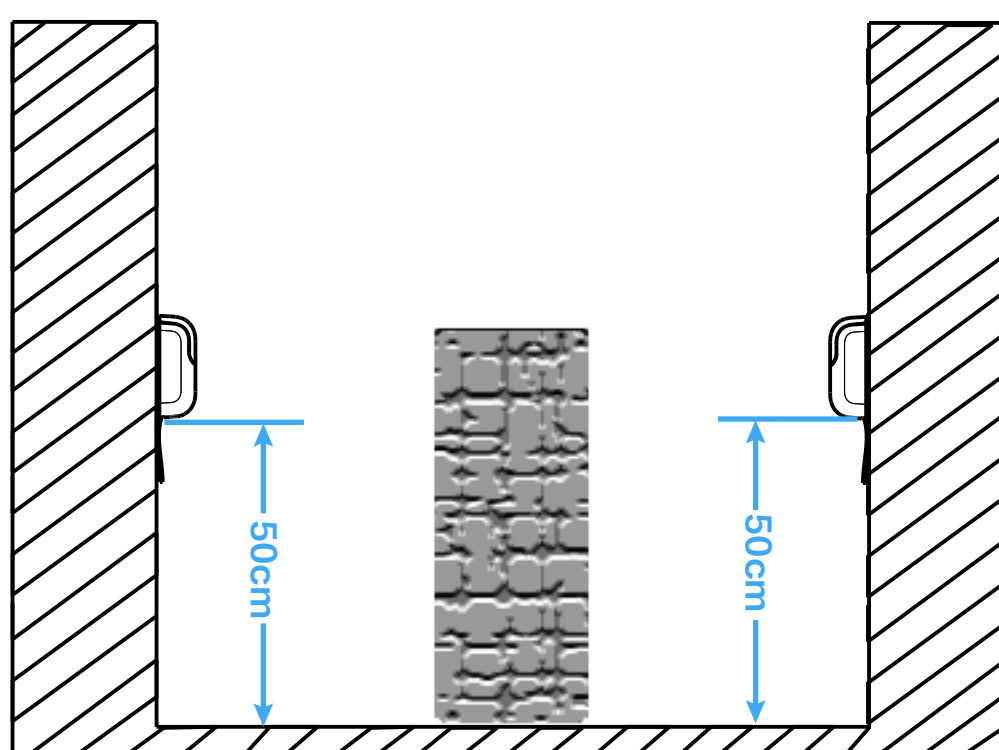

4. Remove the obstacle to check that the IR indicator returns to solid red.
5. Press the "IR" button again to exit the infrared self-testing mode.
6. The IR indicator dims, meaning that the gate opener has successfully exited the infrared self-testing mode.

5. Test Gate Opening/Closing

Use any of the following methods to test whether the gate opener can open and close the gate as expected.

Method 1 (recommended):

Follow the wizard in the EZVIZ app and tap the "Open", "Stop", and "Close" buttons to test whether the gate opener can perform functions properly.

During this process, the gate opener will learn and save the gate travel.

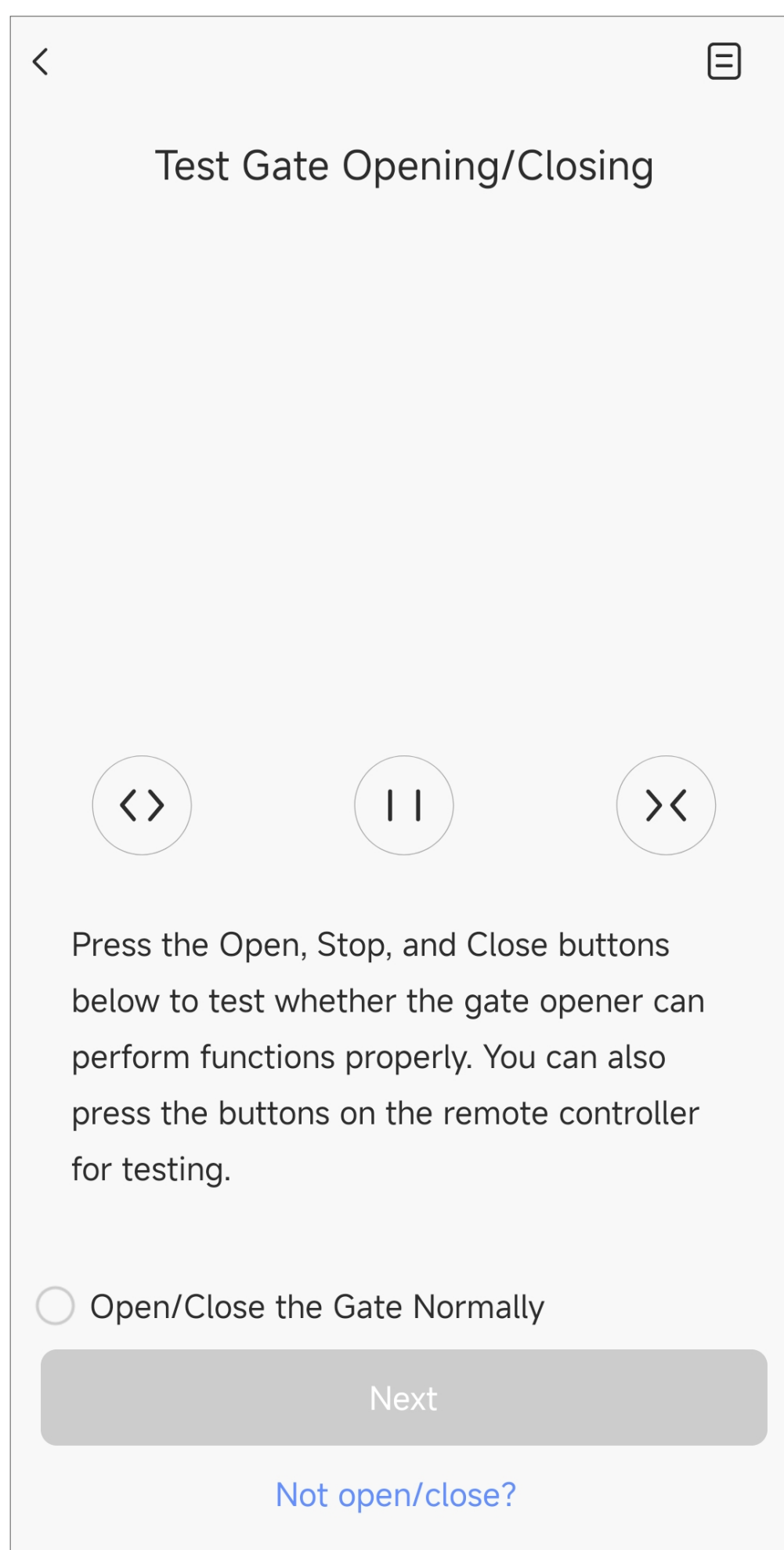

Method 2:

Press the Open, Close, and Stop buttons on the remote controller to check whether the gate can be opened, closed, and stopped as expected.

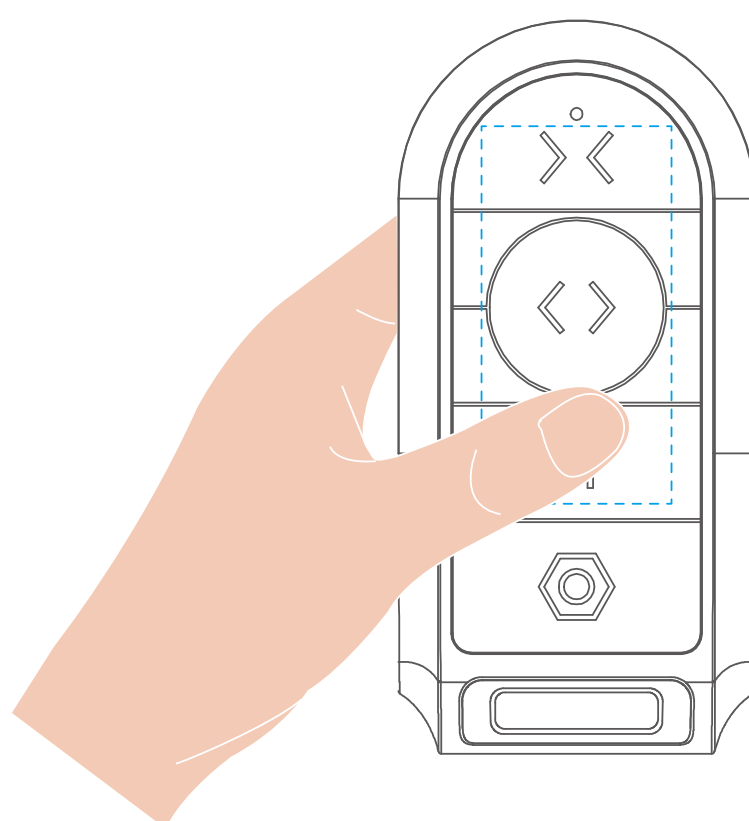

6. Install the Backup Battery

- **Battery information:**
 - Battery model: INR18650-26E 4S1P
 - Rated voltage: DC14.6V
 - Rated capacity: 2400mAh
 - Battery manufacturer: Guangdong Pow-Tech New Power Co. Ltd.
- It is recommended to use the same model of battery or battery with the same specifications for replacement. You can buy additional batteries from EZVIZ.
-  Disposal of a battery into fire or a hot oven, or mechanically crushing or cutting of a battery can result in an explosion.
- Leaving a battery in an extremely high temperature surrounding environment can result in an explosion or the leakage of flammable liquid or gas.
- A battery subjected to extremely low air pressure may result in an explosion or the leakage of flammable liquid or gas.

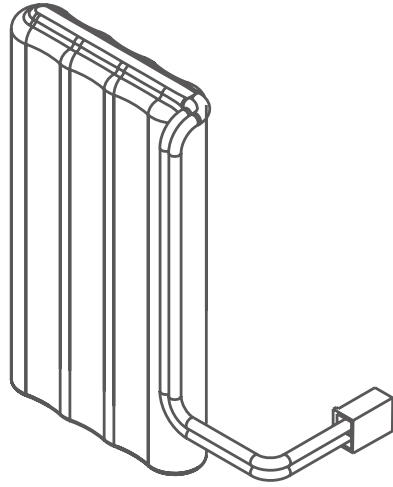

Backup Battery (×1)

1. Insert the backup battery into the battery slot inside the control unit.
2. Connect the battery cable to the battery terminal ("BATT").

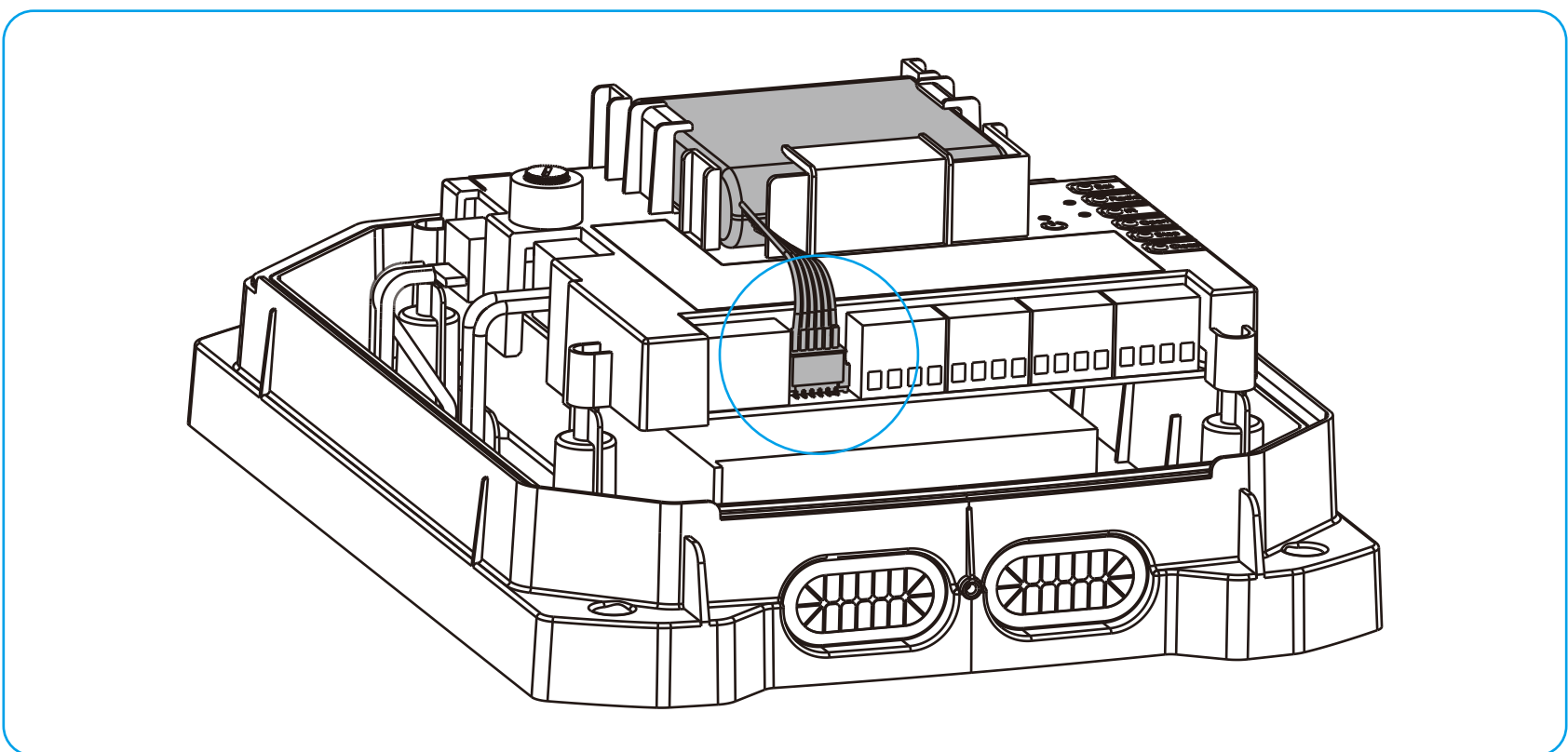

If the backup battery is exhausted, remove the backup battery from the gate opener and replace it with a new one.

1. Unplug the battery cable from the battery terminals ("BATT").
2. Lift the backup battery from the battery chamber.
3. Install a new battery.

7. Close the Gate Opener Cover

1. Put the gate opener cover back on the gate opener.
2. Use a screwdriver to tighten the screws back.

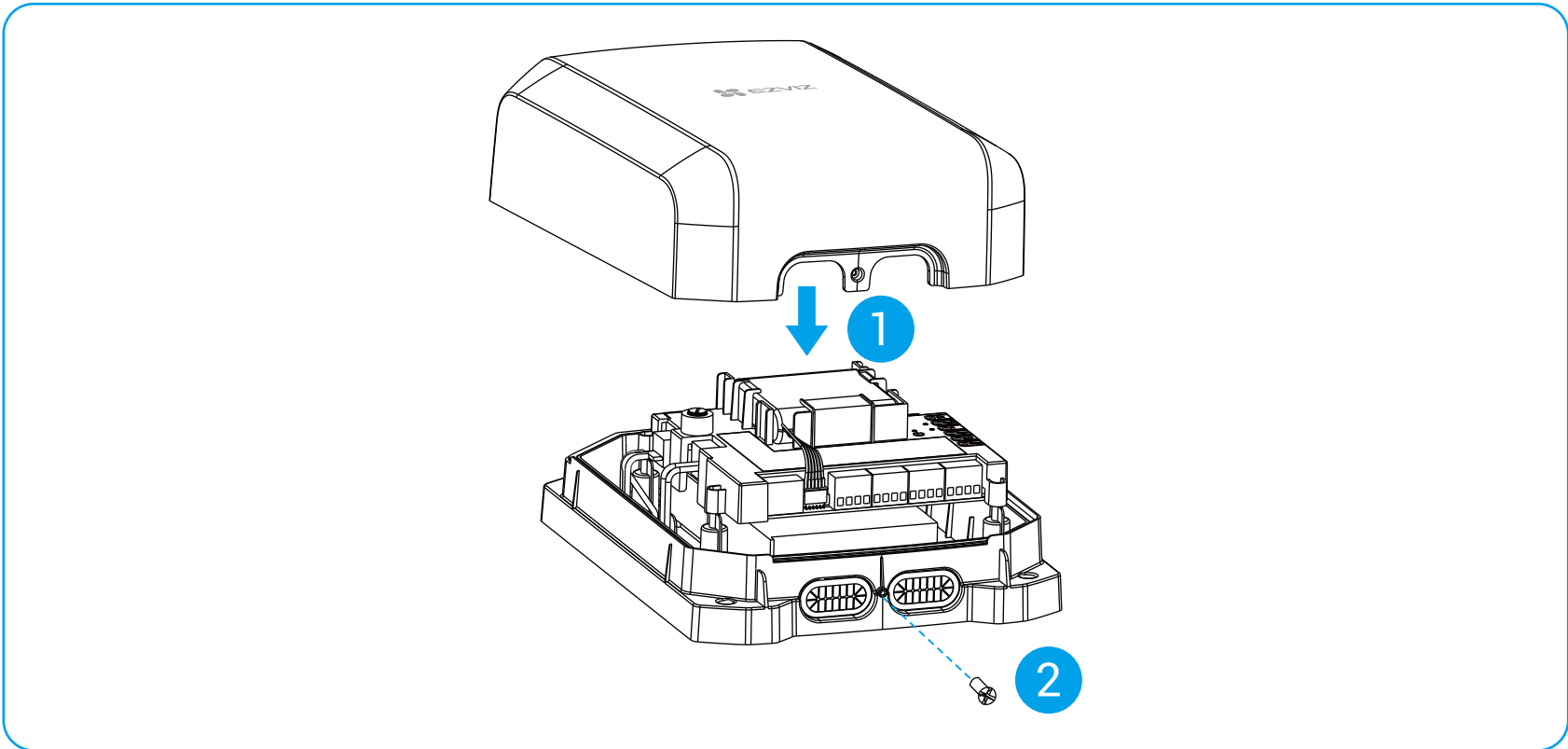

Settings

i The app page may be different due to version update, and the page of the app you installed on your phone shall prevail.

1. Wireless Repeater Management

1.1 Detail Page of Wireless Repeater

In the EZVIZ app, tap the device card of the wireless repeater. The detail page of the wireless repeater appears (as shown below).

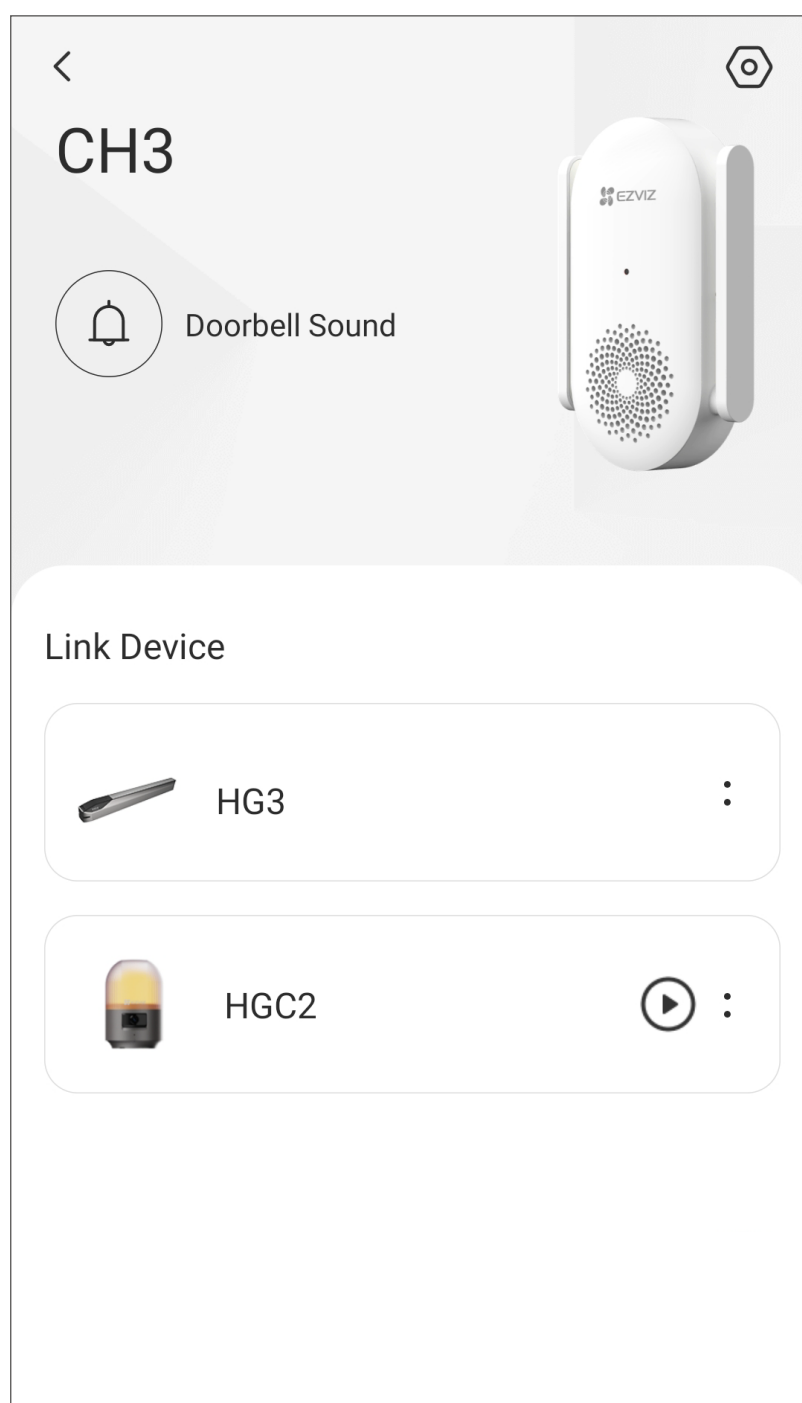

Icon	Description
	Settings. View or change the settings of the wireless repeater.
	Mute. Tap to mute the speaker of the wireless repeater.
	Enter the live view page of the connected alarm light camera.

i After power-on, the gate opener and the alarm light camera will be automatically linked with the wireless repeater, added to your EZVIZ account, and displayed in the "Link Device" area on the detail page of the wireless repeater.

1.2 Wireless Repeater Settings

On the detail page of the wireless repeater, tap the icon to enter the settings page. You can perform the following settings as needed.

Setting	Description
Name	View or tap to customize the name of your wireless repeater here.
Audio Settings	You can adjust the volume of the reminder sound and set the doorbell sound DND (Do Not Disturb) scheme here.

Setting	Description
Light Settings	You can turn on or off the LED indicator here.
Network Settings	You can view the name of the currently connected network or tap to change to another Wi-Fi network.
Device Information	You can see the device information here, including the user guide.
More	You can authorize terminals to add them to your EZVIZ account.
Delete Device	Tap to delete the wireless repeater from the EZVIZ app.

1.3 Binding a New Wireless Repeater

i This operation is only necessary when setting up a newly purchased wireless repeater after your original one becomes unusable. If you have only relocated your gate opener, simply reset the wireless repeater (refer to the description of the RESET button in "Overview").

You can bind a new wireless repeater in two ways:

Method 1 (recommended): Binding a new wireless repeater in the EZVIZ app

1. Plug in the new wireless repeater and add it to your EZVIZ account (for operation details, please refer to ["Add Wireless Repeater to Your EZVIZ Account"](#)).
2. Go to the detail page of the wireless repeater.
3. Tap the binding entry to enter the binding page.
4. Scan the QR code on the control unit.
5. Press and hold the "IR" button on the control unit for 5 seconds. The digital display tube shows "22". The control unit enters the binding mode (effective duration: 300 seconds).

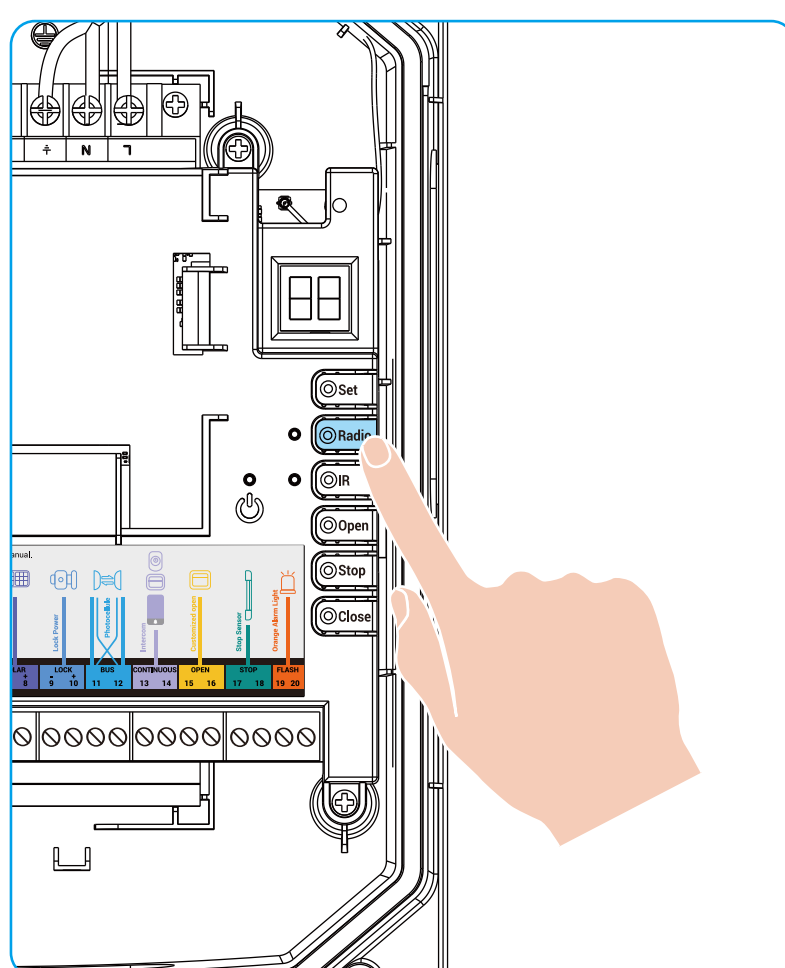

The digital display tube of the gate opener returns to normal. The gate opener has been linked with the wireless repeater and added to your EZVIZ account.

Method 2: Binding a new wireless repeater on the gate opener

1. Plug in the new wireless repeater and add it to your EZVIZ account (for operation details, please refer to ["Add Wireless Repeater to Your EZVIZ Account"](#)).
2. Press and hold the RESET button on the wireless repeater for 10 seconds until the LED indicator becomes fast-flashing red and blue alternately, which indicates that the wireless repeater is now ready for re-binding.

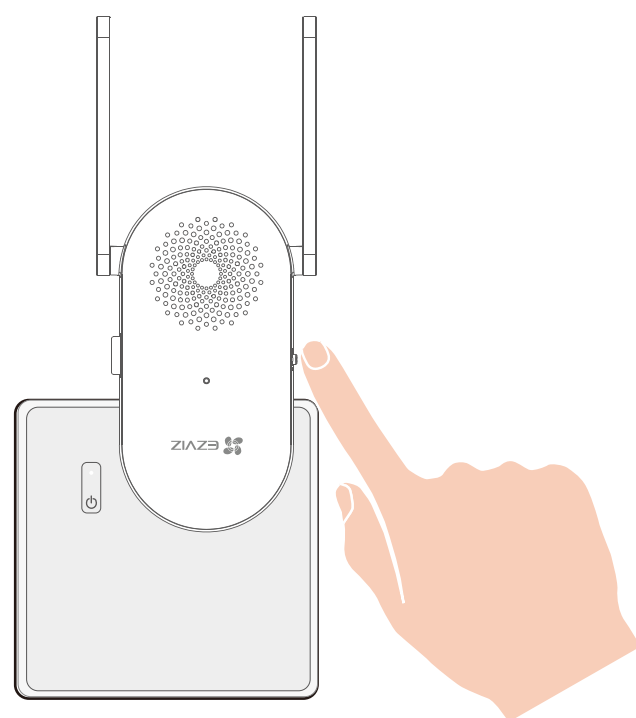

3. Press and hold the "IR" button on the control unit for 5 seconds. The digital display tube shows "22". The gate opener enters the binding mode (effective duration: 300 seconds).

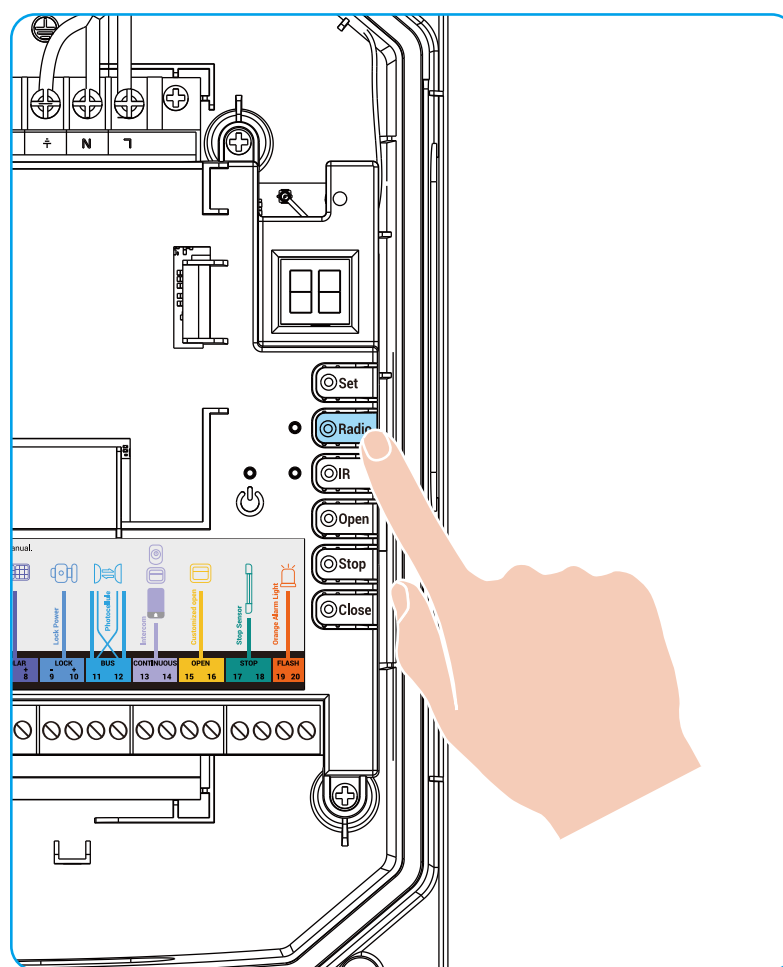

4. When the control unit receives the identity information of the wireless repeater, the digital display tube shows "22" in fast-flashing mode.
5. Press the "IR" button on the control unit. The identity information of the wireless repeater is saved on the gate opener, and the control unit returns a binding success message to the wireless repeater.

The control unit exits the binding mode and the digital display tube returns to normal. The control unit has been linked with the wireless repeater and added to your EZVIZ account.

2. Gate Opener Management



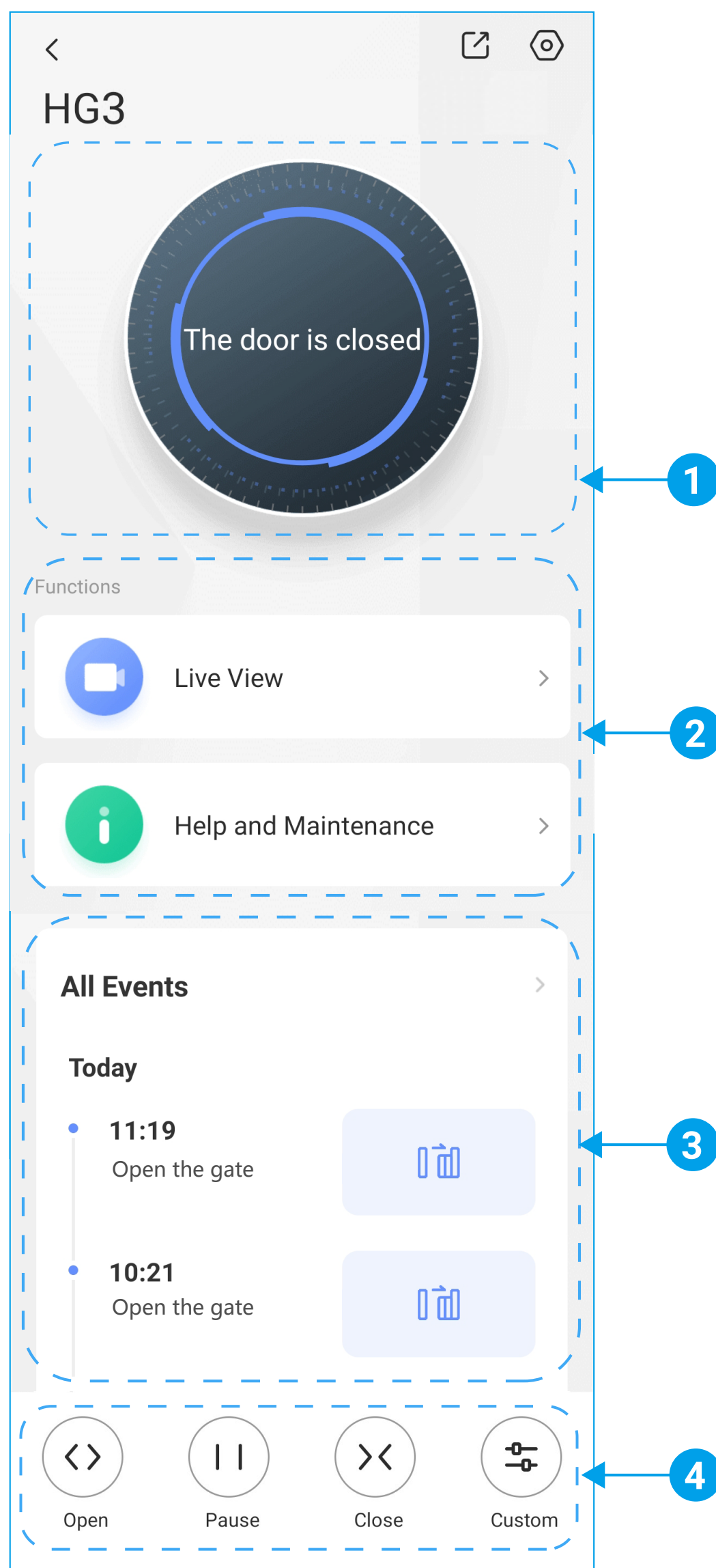

2.1 Detail Page of Gate Opener

In the EZVIZ app, tap the device card of the gate opener. The detail page of the gate opener appears (as shown below).



No.	Area	Description
1	Status	Displays the current state of the gate and error code (if any).
2	Functions	Provides the entry to Live View and the entry to Help and Maintenance.
3	Event Records	Displays all event records.
4	Buttons	Provides four operation buttons for you to control the gate movement in the EZVIZ app.

Icon	Description
	Share. Share your device with anyone you want.
	Settings. View or change the settings of the gate opener.
	Live view. Tap to enter the live view page.

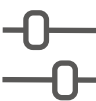
Icon	Description
	Help & Maintenance. Tap to obtain the installation guide, fault assistance, and FAQ.
	Open. Tap to open the gate.
	Stop. Tap to stop the gate.
	Close. Tap to close the gate.
	Custom. Tap to open the gate in custom mode. The gate will open in Pedestrian Mode or Fully Open (according to the custom mode you have set).

- i** If the gate opener is offline, use your phone's Bluetooth to connect and control it:
1. Turn on your phone's Bluetooth.
 2. On the device detail page, tap the Bluetooth icon and confirm to pair.
 3. Enter the verification code (found on the QR code label) and wait for the connection.
 4. Once connected, tap the buttons to control the gate.

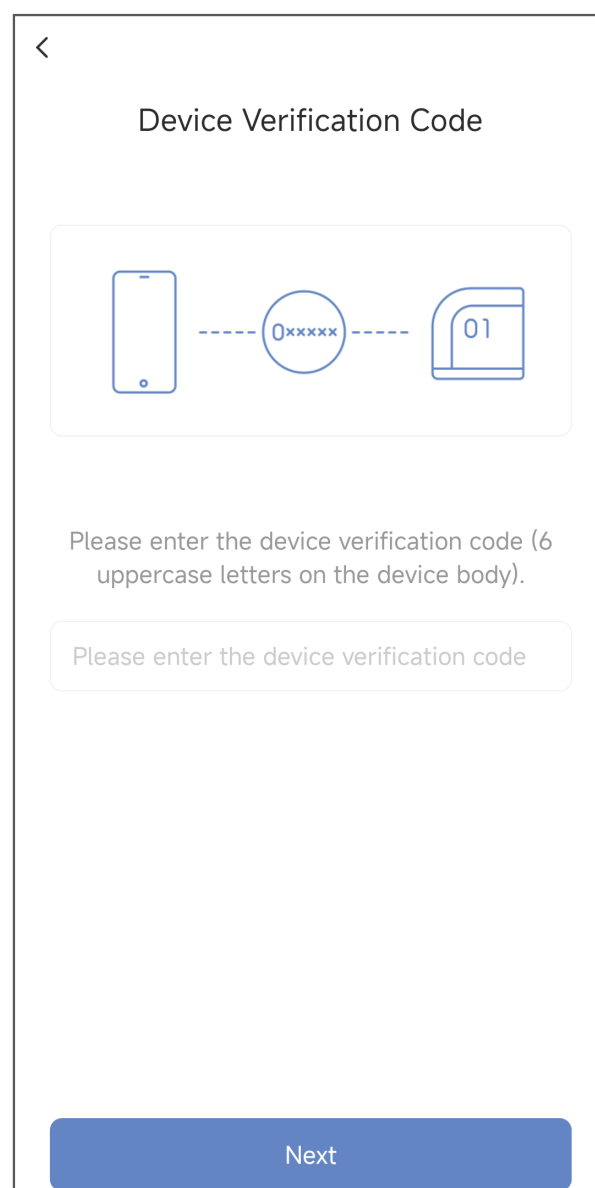
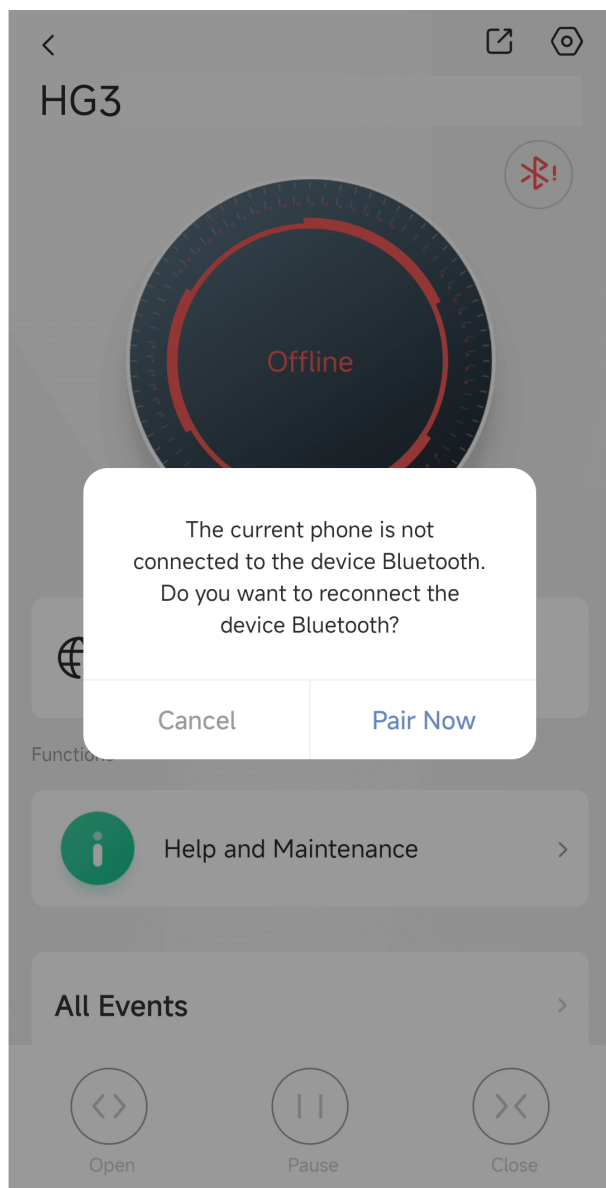

2.2 Gate Opener Settings

Entry 1:

On the detail page of the gate opener, tap the  icon in the upper-right corner to enter the settings page.

Entry 2:

On the detail page of the wireless repeater, tap the device card of the gate opener and select "Gate Opener Settings" to enter the settings page of the gate opener.

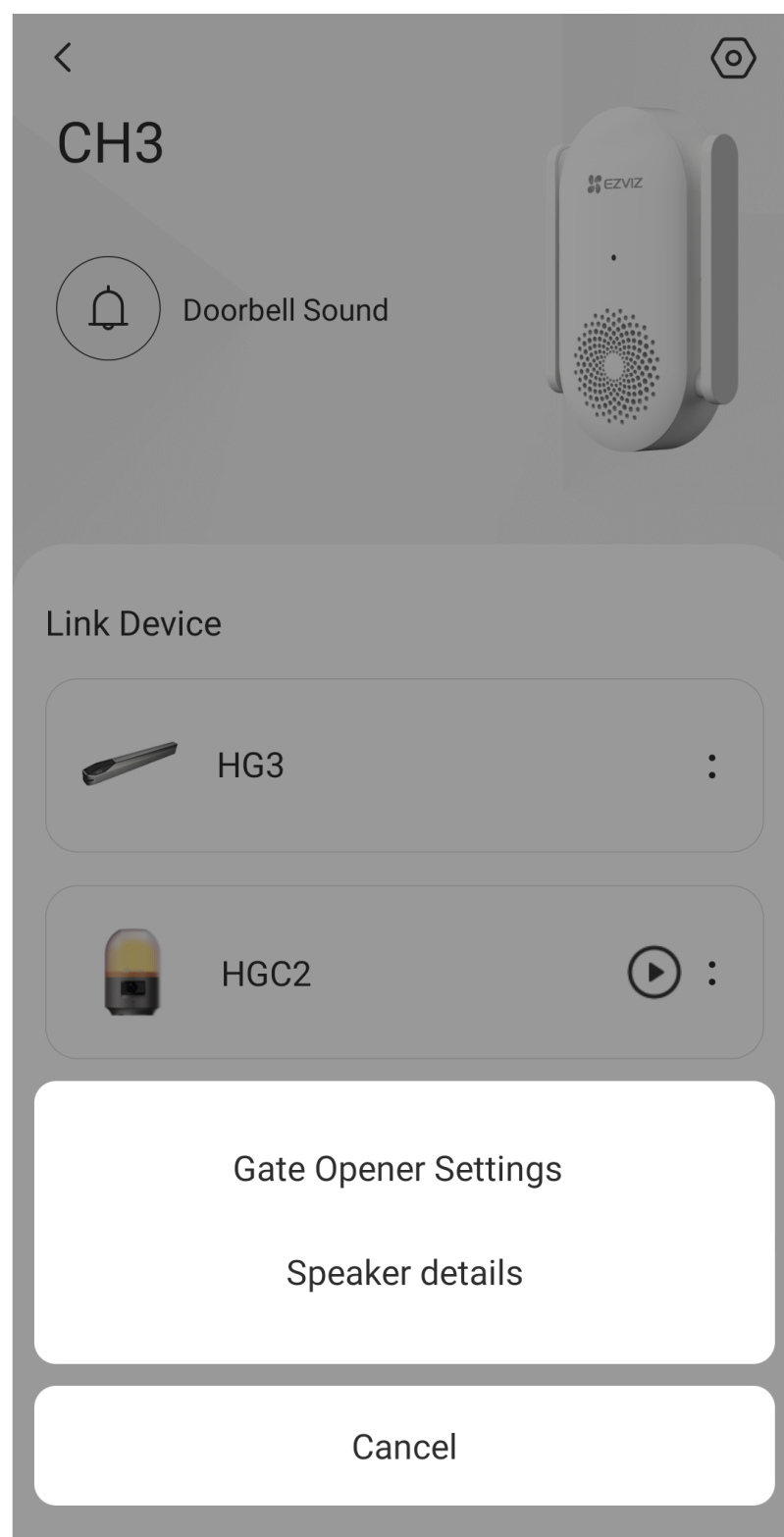

On the settings page of the gate opener, you can perform the following settings as needed.

Setting	Description
Gate Opening/Closing Settings	Configure the gate opening/closing speed, resistance rebound sensitivity, auto closing, custom button setting, and travel re-learning.
Accessory Management	Manage accessories such as remote controllers.
Alarm Light Volume	Set the volume-related parameters for the alarm light camera.
Alarm Light Brightness	Turn on or off the flashing light of the alarm light camera and set the light-related parameters.
Spotlight Setting	If you have connected a spotlight to the gate opener, you can turn on or off the spotlight here.
Message Notification	You can manage the device message and EZVIZ app notification.
Terminal Setting	Configure STOP terminals here.
Network Settings	Check the strength of the signal between the gate opener and the wireless repeater here.  The position of the wireless repeater can be adjusted according to the signal strength to ensure the stable network status of the gate opener.
Device Information	You can see the device information here, including the user guide.
Share Device	You can share the device to your family member or guest.

Setting	Description
Restart Device	Tap to restart the gate opener.
Delete Device	Tap to delete the gate opener from the EZVIZ app.

Set the gate opening/closing speed

If you think the gate opening/closing speed is too fast or slow, you can adjust the speed in two ways:

Method 1 (recommended):

1. On the settings page of the gate opener, tap "Gate Opening/Closing Setting".
2. Based on your actual environment, select a desired gate opening/closing speed by adjusting the slider.

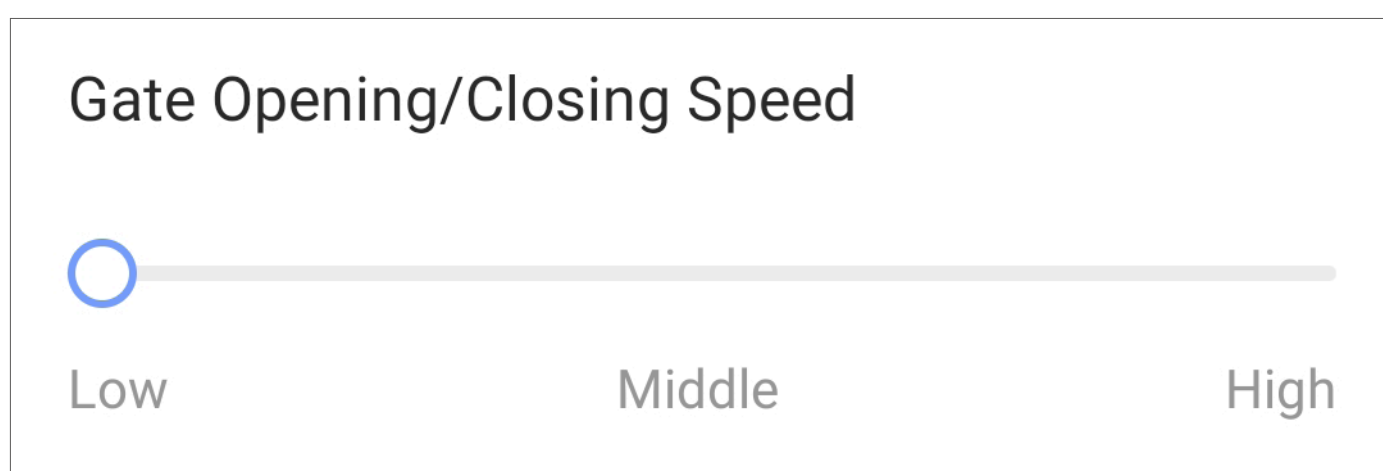

Method 2:

1. Open the cover of the control unit.
2. Press and hold the Set button for 3 seconds to enter the main menu. "P1" is displayed on the digital display tube, which means you are currently configuring the gate opening/closing speed.

i Refer to the table below for correspondence between the code displayed and the submenu.

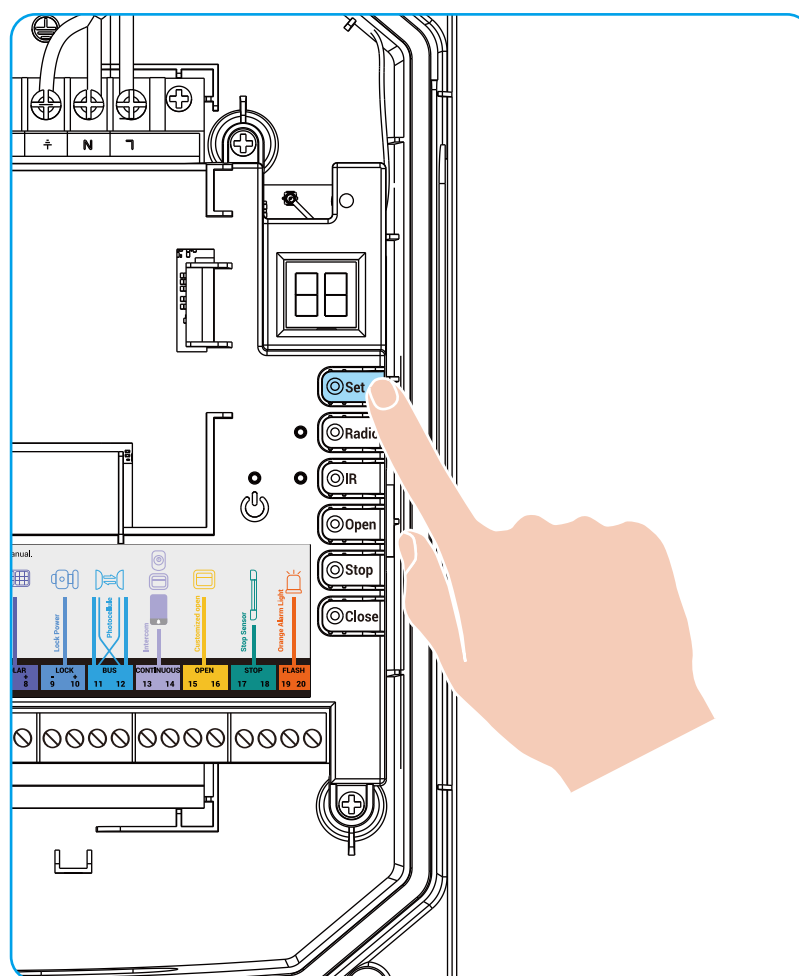

Code Displayed	Submenu
P1	Gate opening/closing speed
P3	Resistance rebound sensitivity

3. Press the Stop button to enter the "P1" submenu. The current speed level is displayed.

i Refer to the table below for correspondence between the code displayed and the speed level.

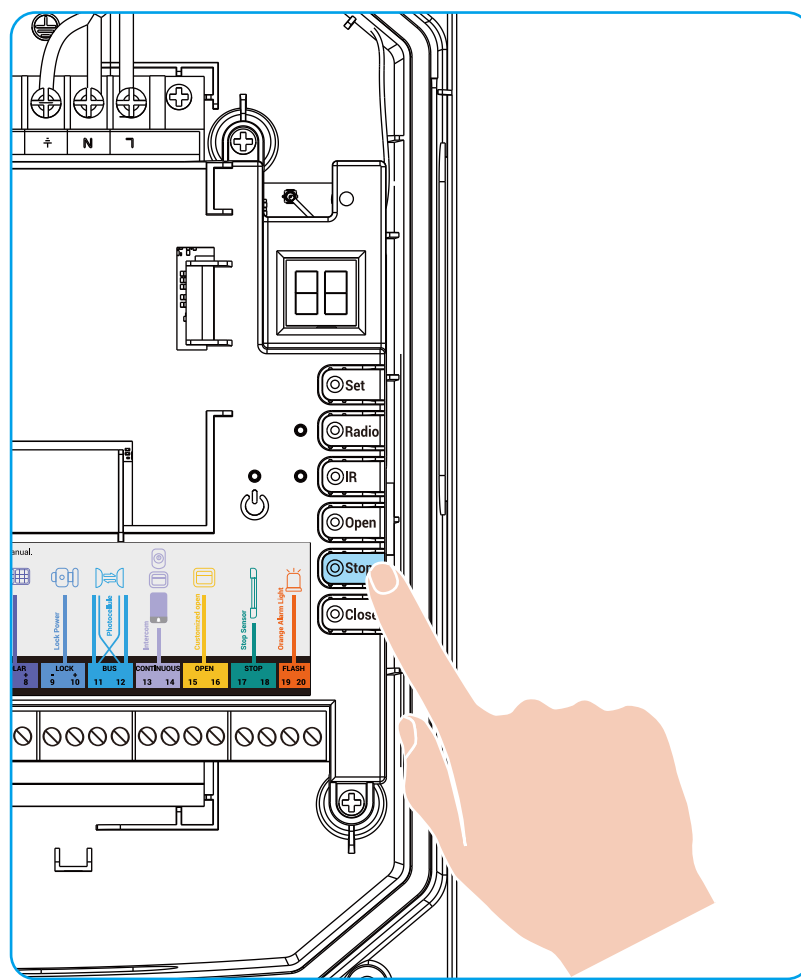

Code Displayed	Speed Level
01	Low
02	Middle
03	High

4. Press the Open or Close button until your desired speed level is displayed on the digital display tube.
5. Press the Stop button. The gate opener system goes back to the main menu.

Set the resistance rebound sensitivity

It is recommended to adjust the resistance rebound sensitivity based on your actual environment. For example, if there is no obstacle along the gate travel, but still an obstacle is detected, you can adjust the sensitivity level lower. You can adjust the resistance rebound sensitivity in two ways:

Method 1 (recommended):

1. On the settings page of the gate opener, tap "Gate Opening/Closing Settings".
2. Based on your actual environment, select a desired resistance rebound sensitivity level by adjusting the slider.

Resistance Rebound Sensitivity

If the sensitivity level is high, the moving gate is prone to rebound when hitting a person or an object. If the sensitivity level is low, the moving gate will not rebound but cause a larger collision force. Please exercise caution before adjustment. If your gate is heavy or environmental resistance is high, high sensitivity may cause false rebounds. In such cases, the sensitivity can be appropriately reduced.

Method 2:

1. Open the cover of the gate opener.
2. Press and hold the Set button for 3 seconds to enter the main menu.
3. Press the Open or Close button until "P3" is displayed on the digital display tube.
4. Press the Stop button to enter the "P3" submenu. The current sensitivity level is displayed.

i Refer to the table below for correspondence between the code displayed and the gate opening direction.

Code Displayed	Resistance Rebound Sensitivity
01	Low
02	Mid-Low
03	Middle
04	Mid-High
05	High

5. Press the Open or Close button until your desired sensitivity level is displayed on the digital display tube.
6. Press the Stop button. The gate opener system goes back to the main menu.

i If the resistance in your gate installation environment is large or your gate is heavy, it is recommended to set a low gate speed and a high resistance rebound sensitivity level and fix a force limiter at both the primary and secondary edges of the gate frame.

Set auto closing

For security reasons, this gate opener provides the auto closing function to prevent any potential security threat caused by forgetting to close the gate. When this function is enabled, the gate can automatically close after the specified period of time if the gate receives no control signal within that time.

1. On the settings page of the gate opener, tap "Gate Opening/Closing Settings" > "Auto Closing".
2. Turn on the "Auto Closing" switch to enable the function.
3. Select an interval for auto closing.

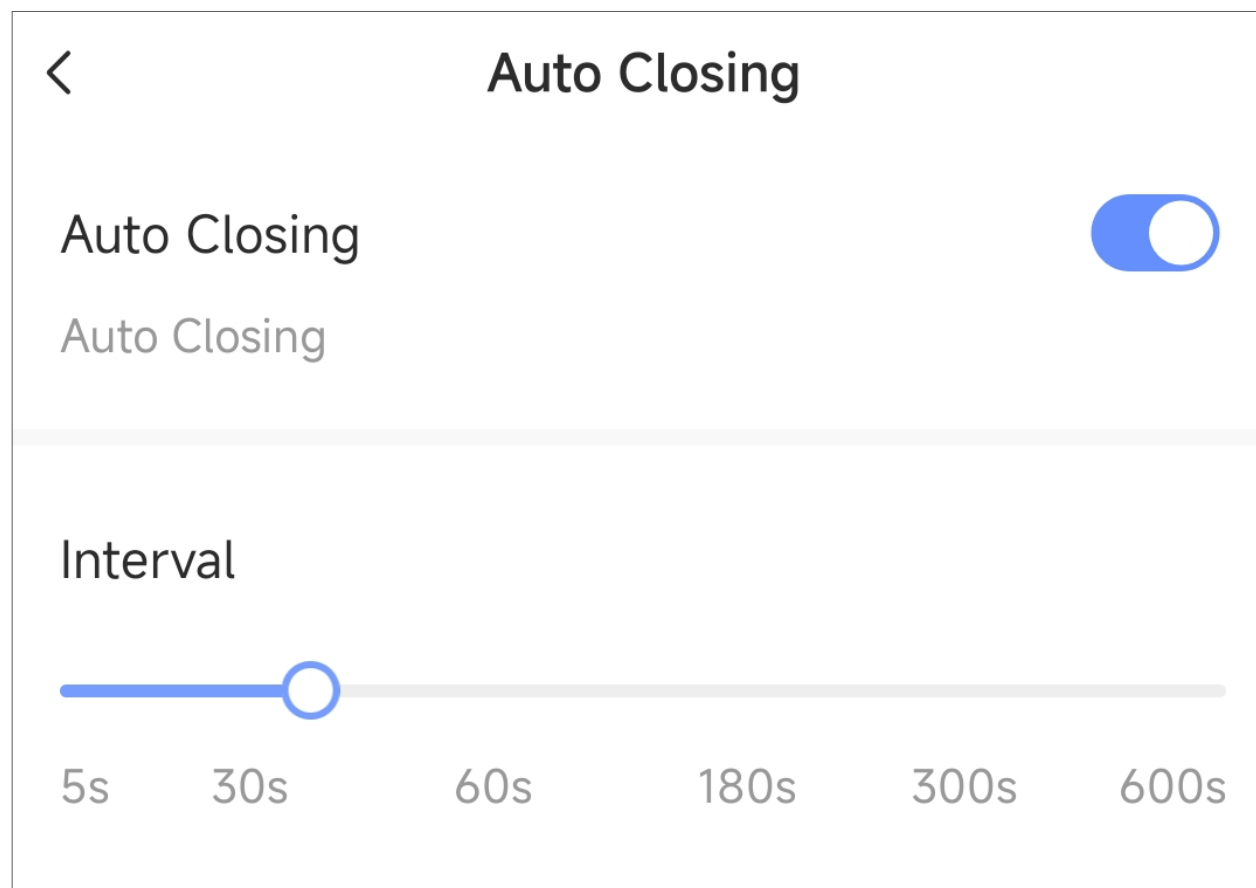

Configure the custom button setting

If you have connected a customized open controller to your gate opener, you can select a customized opening mode in the EZVIZ app.

1. On the settings page of the gate opener, tap "Gate Opening/Closing Settings".
2. Tap "Custom Button Setting".
3. Select a customized opening mode as needed.

Option	Description
Pedestrian Mode	The gate will only open the leaf driven by the MOTOR 1 after you perform a gate opening operation.
Fully Open	The gate will be fully open after you perform a gate opening operation.

Clear and re-learn the gate travel

After you adjust the installation position of the gate opener, you can follow the steps below to manually clear and re-learn the gate travel.

Method 1 (recommended):

1. On the settings page of the gate opener, tap "Gate Opening/Closing Settings".
2. Tap "Travel Re-learning".
3. A prompt message appears. Tap "Continue".

i Performing this travel re-learning operation will clear the existing travel. Proceed with caution.

Method 2:

1. Open the cover of the control unit.
2. Press and hold the Stop button for 5 seconds.
3. The digital display tube shows a fast-flashing "11" for 3 seconds, indicating that the learned gate travel has been cleared.
4. Press the Custom button on the remote controller. The gate opener will start re-learning the travel. Wait until it completes.

i During travel re-learning, do not artificially block or interfere with the gate movement.

Alarm Light Settings

i **Important:**
The volume and brightness settings are set on the settings page of the gate opener, not on the settings page of the alarm light camera.

You can set the volume and brightness of the alarm light camera on the settings page of the gate opener.

To set the volume of the alarm light camera:

Go to the settings page of the gate opener and tap "Alarm Light Volume".

- Alarm Light Volume
When enabled, the alarm light will make a sound when the gate is opened.
- Do Not Disturb
If you enable this function and set a time period, the alarm light will not make sounds during the specified time period.
- Bell Volume
You can set a desired volume of alarm sounds by adjusting the slider.

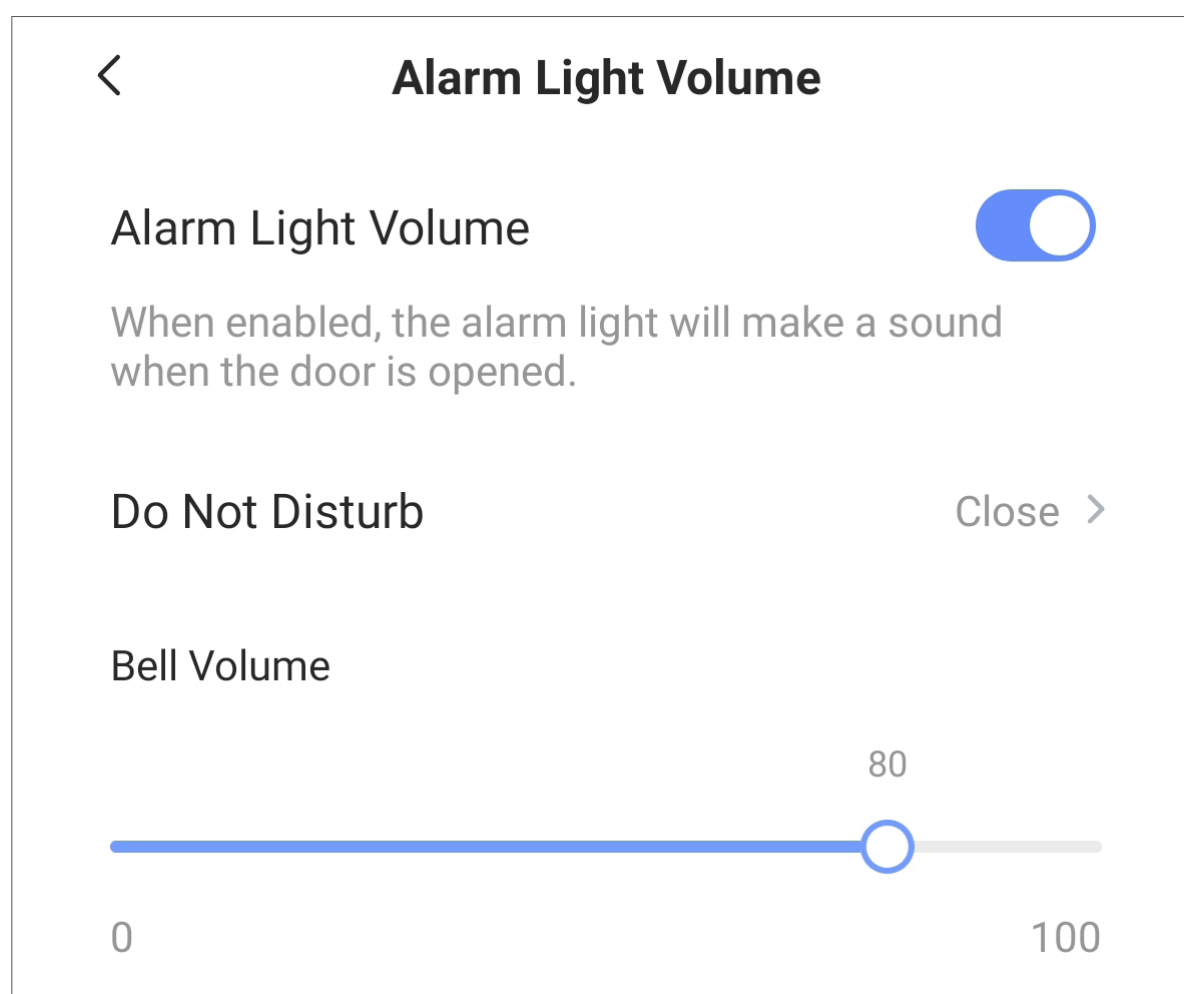

To set the brightness of the alarm light:

Go to the settings page of the gate opener and tap "Alarm Light Brightness".

- **Device Flashing Light**
When enabled, the alarm light will be turned on when the gate is in motion (either opening or closing).
- **Flashing Light Type**
When the device flashing light is enabled, you can select a flashing light type here as needed.
- **Flashing Light Brightness**
You can set a desired brightness level of the alarm light by adjusting the slider.

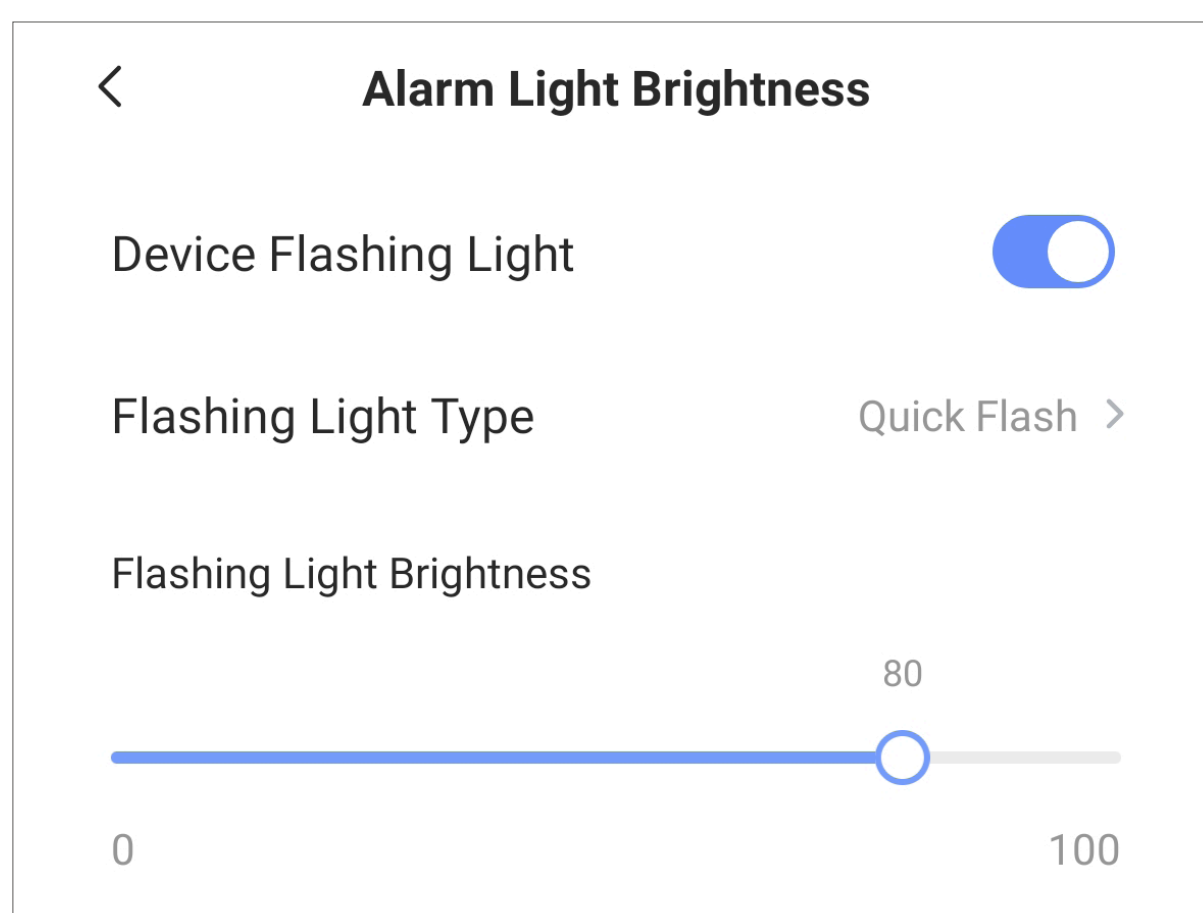

Gate Opener Reset

1. Open the cover of the control unit.
2. Press and hold the Set button for 8 seconds until the digital display tube shows a fast-flashing "88".
3. After 3 seconds, the gate opener is restored to factory settings.

i **Resetting the gate opener will clear all user data and user-defined settings, such as the learned gate travel, setting parameters, remote controller pairing, and network information, will be cleared.**

2.3 Speaker Settings

To configure speaker settings for the gate opener, follow the steps below:

1. On the detail page of the wireless repeater, tap the device card of the gate opener and select "Speaker Details".
2. On the "Speaker Details" page, you can turn on the Door Opening Reminder and select a reminder sound as you like.
3. Tap "Save" in the upper-right corner.

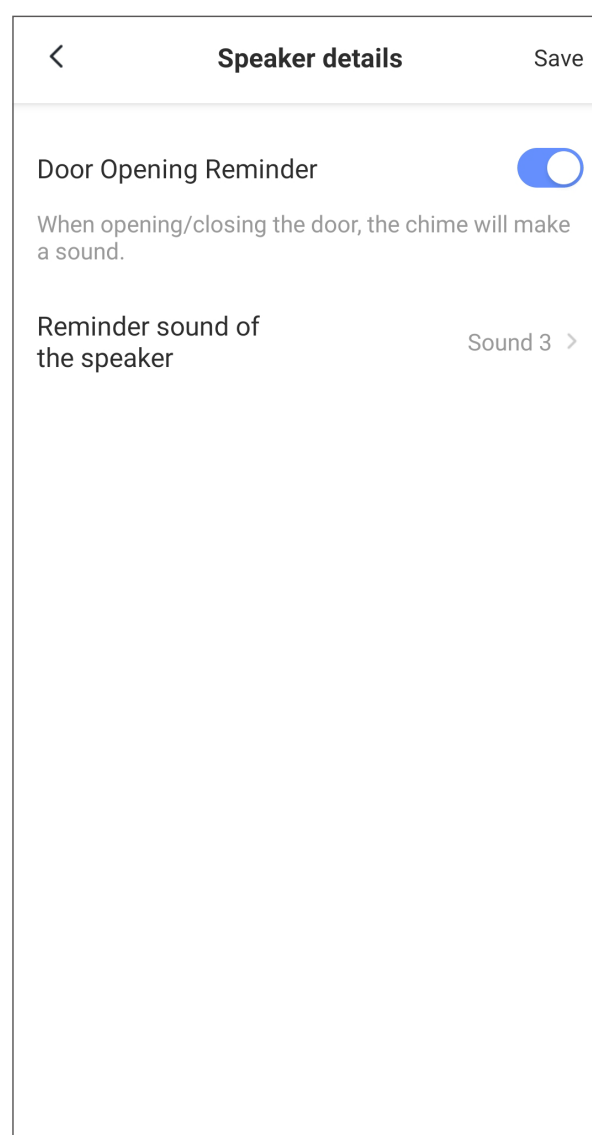
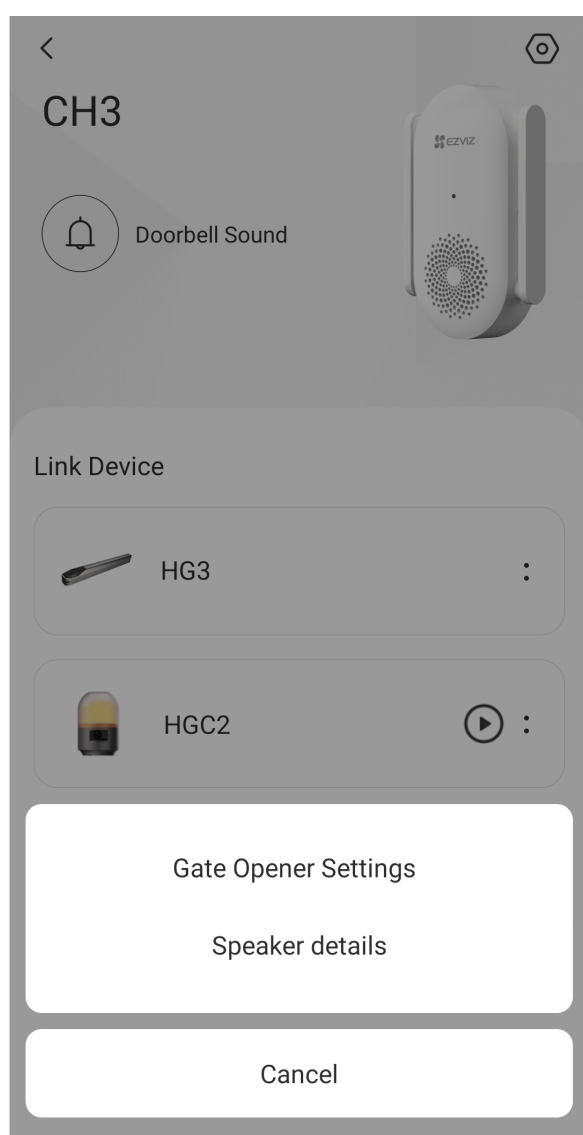

After you enable the Door Opening Reminder, each time when the gate is opened or closed, the wireless repeater will make a sound.

3. Alarm Light Camera Management

3.1 Live View

Entry 1:

In the EZVIZ app, tap the device card of the alarm light camera.

Entry 2:







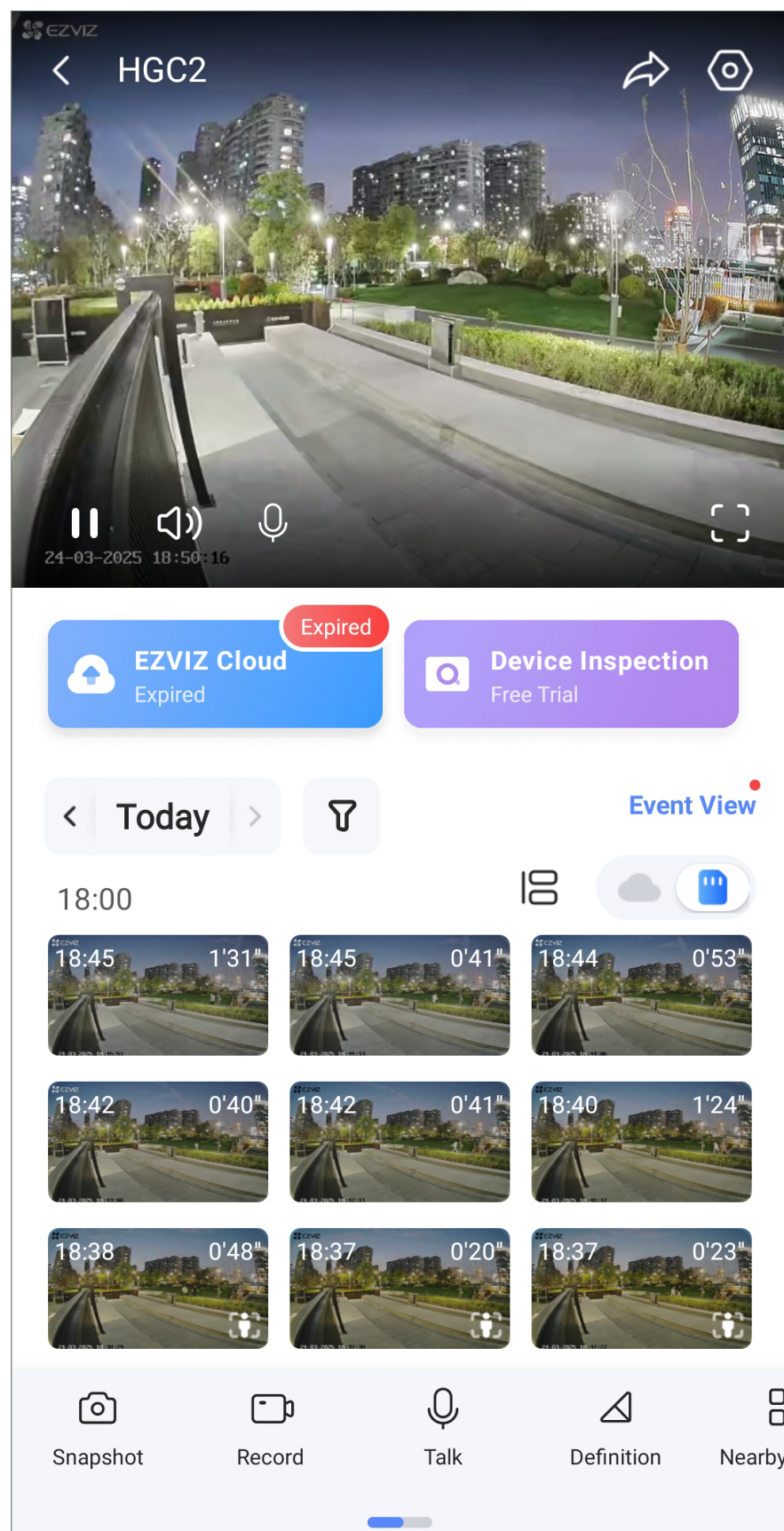

On the detail page of the gate opener, tap "Live View".







Entry 3:

On the detail page of the wireless repeater, tap the  icon in the device card of the alarm light camera.

The live view page of the alarm light camera is shown as below.



Icon	Description
	Share. Share your device with anyone you want.
	Settings. View or change the settings of the alarm light camera.
	Pause/play. Pause or play the live view.
	Sound. Turn on or off the sound in the live view.
	Talk. Tap the icon, and then follow the on-screen instructions to talk to or listen to people near the camera.
	Full screen. Watch the live view in full screen mode.
	(Visible only in full screen mode) View historical video clips.
	Snapshot. Tap to take a snapshot of the live view.

Icon	Description
	Record. Manually start/stop recording.
	Resolution. Select a video resolution as needed.
	Nearby Device. Tap to check available devices nearby.
	Picture in Picture (PiP). Tap the icon, the current screen will become a separate small window that can float on top of another app on your mobile phone.
	Tip. Tap to see more information about the device.
	Rearrange. Rearrange the sequence of all the functions above.

3.2 Camera Settings

-  To set the volume or brightness of the alarm light camera, go to the settings page of the gate opener and choose "Alarm Light Volume" or "Alarm Light Brightness".

On the live view page, tap the  icon to enter the settings page of the alarm light camera.

Setting	Description
Name	View or tap to customize the name of your alarm light camera here.
Intelligent Detection	You can select between different detection types for your alarm light camera.
Message Notification	You can manage the device message and EZVIZ app notification.
Audio Settings	You can set relevant audio parameters for your device.
Image Settings	You can set relevant image parameters for your device.
Record List	You can select between different recording modes for your device and see the microSD™ card status here.
Privacy Settings	You can encrypt your videos with encryption password and customize the privacy area.
Network Settings	You can see the connected Wi-Fi network, perform bandwidth detection and enable the wireless testing mode.
Device Information	You can see the device information here, including the user guide.
Share Device	You can share the device to your family member or guest.
EZVIZ Cloud	You can subscribe and manage the cloud storage.
Device Inspection	You can subscribe the device inspection here.
Delete Device	Tap to delete the alarm light camera from EZVIZ app.

3.3 Speaker Settings

To configure speaker settings for the alarm light camera, follow the steps below:

1. On the detail page of the wireless repeater, tap the device card of the alarm light camera and select "Speaker Details".
2. On the "Speaker Details" page, you can turn on the Smart Detection Sound Reminder and select a reminder sound as you like.
3. Tap "Save" in the upper-right corner.

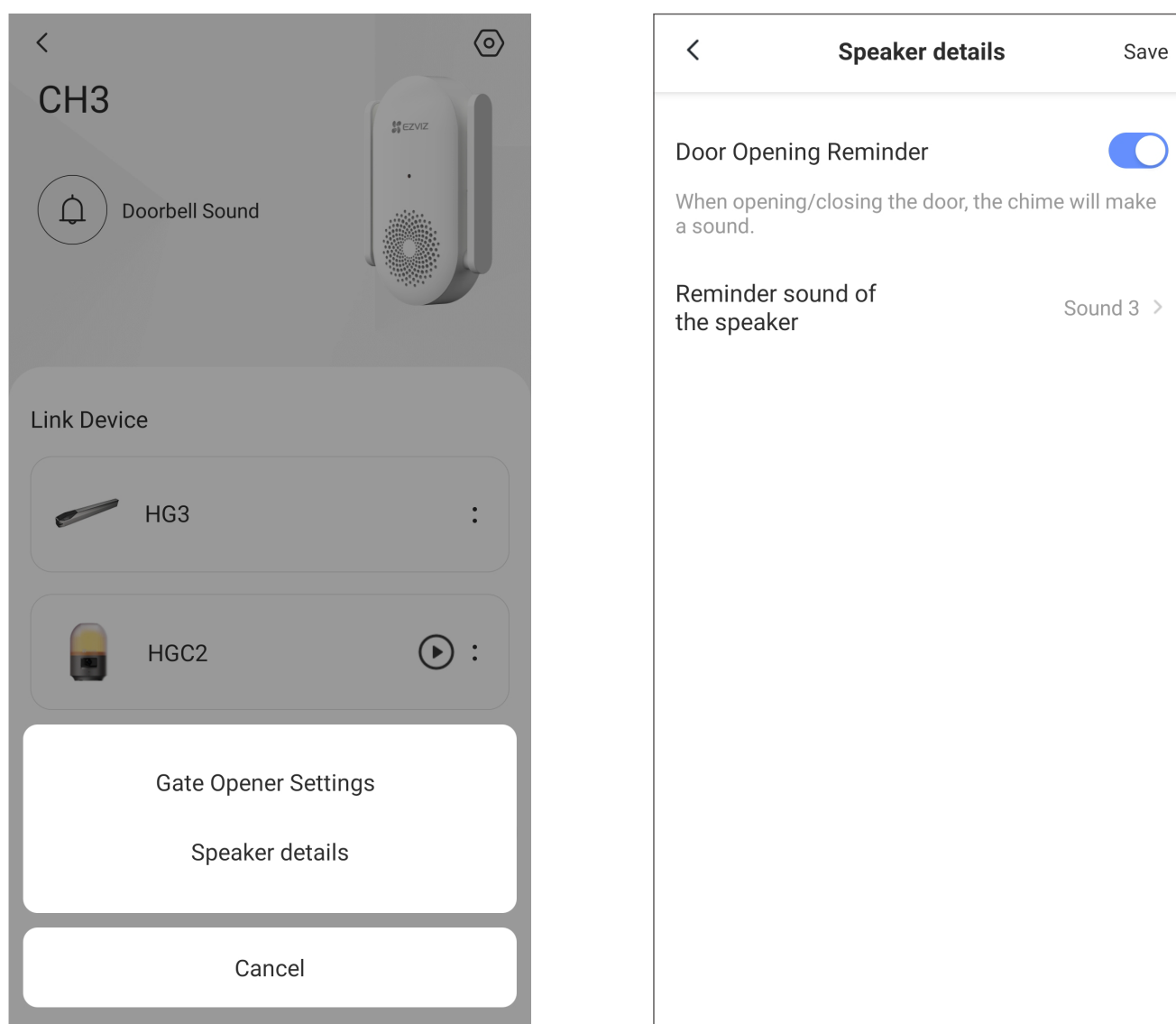

After you enable the Smart Detection Sound Reminder, each time when smart detection of the camera is triggered, the wireless repeater will make a sound.

Error Codes

Error Code	Meaning	User Action	Gate opening and closing normal?
E0	Failed to start self-test	Contact EZVIZ customer service.	No
E2	Abnormal Current Sampling	Contact EZVIZ customer service.	No
E3	Battery Undervoltage	<ol style="list-style-type: none"> 1. Open the circuit breaker of the gate opener or the main circuit breaker in your home to disconnect the gate opener from power. 2. Remove the cover of the main motor. Unplug the battery cable and then insert it back. 3. If the error persists, connect the gate opener to the mains supply to charge the battery for 1 to 2 hours, then disconnect from mains supply and power the gate opener using the battery to check whether the error still occurs. 4. If the error persists, you are advised to buy an EZVIZ battery and install it on the gate opener. 5. If you have any other questions, contact EZVIZ customer service. 	No
E4	Operation timeout	<ol style="list-style-type: none"> 1. Check whether the motors are correctly locked. 2. Check whether the motor stop blocks are dislocated. 3. If you have any other questions, contact EZVIZ customer service. 	No
E5	Obstacles persist	<ol style="list-style-type: none"> 1. Check whether obstacles exist on the guide rail and remove them. 2. If the error persists, you are advised to buy EZVIZ motor sensors to replace the faulty sensors. 3. If you have any other questions, contact EZVIZ customer service. 	No
E6	Obstruction Fault	<ol style="list-style-type: none"> 1. Check whether obstacles exist on the guide rail and remove them. 2. Check whether the gate opener and arms are installed correctly. Specifically, use the key supplied to unlock the gate opener and open and close the gate completely to check for any obvious resistance. If necessary, adjust the installation position of the gate opener. 3. If the error persists, contact EZVIZ customer service. 	No
E8	Power supply undervoltage	Contact EZVIZ customer service.	Yes
E9	Drive Circuit Malfunction	Contact EZVIZ customer service.	No

Error Code	Meaning	User Action	Gate opening and closing normal?
F1	Battery Overvoltage	<ol style="list-style-type: none"> 1. Open the circuit breaker of the gate opener or the main circuit breaker in your home to disconnect the gate opener from power. 2. Remove the gate opener cover. Unplug the battery cable and remove the battery. 3. You are advised to buy an EZVIZ battery and install it on the gate opener. Then install the gate opener cover back. 4. If you have any other questions, contact EZVIZ customer service. 	Yes
F2	Overvoltage in High-Voltage System	Contact EZVIZ customer service.	Yes
F5	First-level over temperature (HaLow module)	<ol style="list-style-type: none"> 1. Wait 10 minutes before opening or closing the gate. 2. If you have any other questions, contact EZVIZ customer service. 	Yes
F7	Wi-Fi/HaLow offline	<ol style="list-style-type: none"> 1. Check whether the distance between the gate opener and the wireless repeater meets the requirement: "The wireless repeater should be installed within 30 meters (with two walls in between at most and no other obstructions) from the gate opener." 2. You can re-install the wireless repeater closer to the gate opener. 3. If you have any other questions, contact EZVIZ customer service. 	Yes
F8	Device Offline	<ol style="list-style-type: none"> 1. Check whether the network connection between the gate opener and the wireless repeater is normal. 2. If you have any other questions, contact EZVIZ customer service. 	Yes
F9	Control Frequency exceeds the limit	<ol style="list-style-type: none"> 1. The gate has been opened and closed too frequently and over temperature protection has been triggered on the gate opener. Please wait 40 minutes before opening and closing the gate again. 2. If you have any other questions, contact EZVIZ customer service. 	No

Technical Data

Motor	
Motor type	24V DC
Input power	100-240V AC 50Hz/60Hz; 14.6V DC by backup battery
Maximum power	250W
Rated operating time	15 minutes
Maximum frequency of movements	15 cycles per hour 360 cycles per day * Tested under 90-degree gate, device operating at low speed setting
Lock power output	DC 12V 1.5A
Photocellule input	Max 2 pairs, no polarity
Continuous open/stop/close input	Normal open dry contact, allow multiple inputs
Open	Normal open dry contact, allow multiple inputs
Stop	Normal close dry contact default, switchable to normal open dry contact in app
Alarm light camera output	DC 10-18V 700mA
Light output	240V AC Maximum power 100W
Operation conditions	-20°C to 60°C, humidity 95% or less (non-condensing)
Protection rating	IP55
Number of remote controllers	Maximum 8

Alarm Light Camera	
Resolution	2048*1536
Day & Night Mode Switch	IR-cut filter with auto-switching
Connection Method	Wired connection (2-wired), digital signal transmission
Intelligent Alarm	Smart human motion detection + Loitering detection
Operation conditions	-30°C to 55°C, humidity 95% or less (non-condensing)
Protection rating	IPX5

Wi-Fi HaLow Repeater	
Power supply	AC 100-240V
Wi-Fi STANDARD	Wi-Fi 6: IEEE802.11b, 11g, 11a, 11n, 11ac, 11ax; Wi-Fi HaLow: IEEE802.11ah
Module	Wi-Fi 6 2.4GHz/5GHz HaLow

Photocellules

Content	1 TX transmitter and 1 RX receiver
Power supply	12V DC
Maximum rated power	0.8 W (TX&RX)
Distance	8m MAX
Operation conditions	-30°C to 60°C, humidity 95% or less (non-condensing)
Protection rating	IP55

Remote Controller

Frequency	433MHz
Open field range	60m
Power	3V - CR2032
Button	4 buttons (extra 1 reset button inside)
Battery lifetime	1 year based on 20 uses of 2 seconds. per day
Operation conditions	-10°C to 45°C, humidity 95% or less (non-condensing)

Warranty

The warranty period for the gate opener is 5 years.

The warranty period for the photocellules, the remote controllers, the alarm light camera, and the wireless repeater is 3 years.

Name	Warranty Period
Cylinder Swing Gate Opener	5 years
Photocellules	3 years
Remote Controllers	
Alarm Light Camera	
Wi-Fi HaLow Repeater	

- i** The warranty of this product covers the assurance of its basic functions, and does not include cosmetic damage.

Help & Support

Entry 1 to Help and Support

If you have any questions regarding the use of this product, please view the Help and Maintenance information in the EZVIZ app.

1. Go to the detail page of the gate opener.
2. Tap "Help and Maintenance".
3. On the "Help and Maintenance" page, you can view the installation guide and fault assistance, as well as the FAQ.

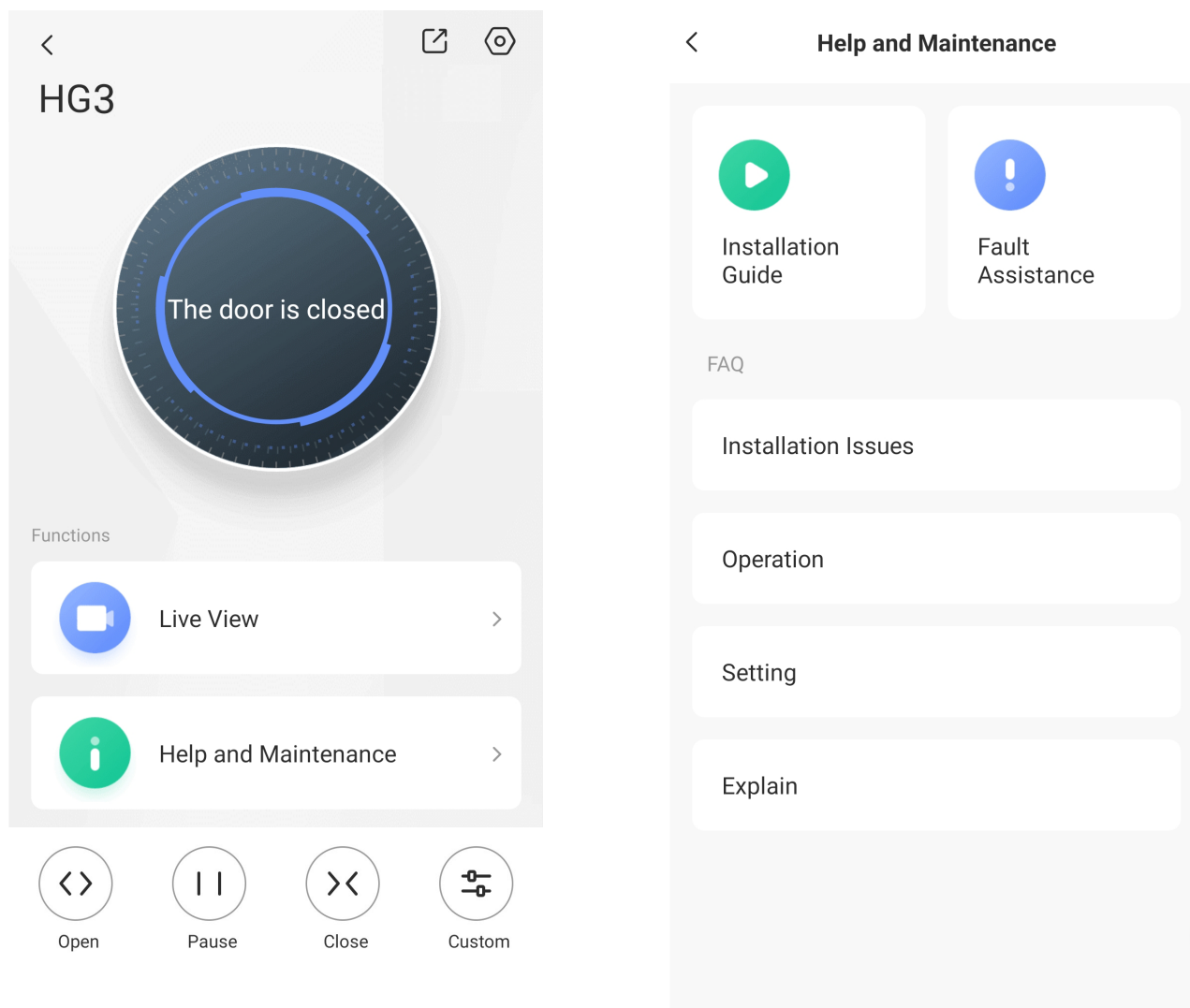

Entry 2 to Help and Support

You can also click the link (<https://www.ezviz.com/page/hg3-300-Pro-choose-language>) or scan the QR code on the cover of this user manual to watch the tutorial videos of this product on EZVIZ's official website.

Entry 3 to Help and Support

If you have any further questions, please contact the EZVIZ official customer service at support@ezviz.com.

Initiatives on the Use of Video Products

Dear Valued EZVIZ Users,

Technology affects every aspect of our life. As a forward-looking tech company, we are increasingly aware of the role technology plays in improving efficiency and quality of our life. At the same time, we are also aware of the potential harm of its improper usage. For example, video products can record real, complete and clear images, therefore they hold great values in representing facts. Nevertheless, improper distribution, use and/or processing of video records may infringe on the privacy, legitimate rights and interests of others.

Committed to innovating technology for the good, we at EZVIZ hereby earnestly advocate that every user shall use video products properly and responsibly, thus to collectively create a positive environment where all related practices and usage comply with applicable laws and regulations, respect individuals' interests and rights, and promote social morality.

Here are EZVIZ's initiatives that we'd appreciate your attention:

1. Each individual possesses a reasonable expectation of privacy, and the use of video products should not be in conflict with such reasonable expectation. Therefore, a warning notice which clarifies the monitoring range should be displayed in a reasonable and effective manner, when installing video products in public areas. For non-public areas, the rights and interests of people involved shall be evaluated thoughtfully, including but not limited to, installing video products only after obtaining the consent of the stakeholders, and not installing highly-invisible video products without other's knowledge.
2. Video products objectively records footage of real activities within specific time and space. Users shall reasonably identify the people and rights involved in this scope in advance, to avoid any infringement of portrait, privacy or other legal rights of others while protecting themselves through video products. Notably, if you choose to enable the audio recording function on your camera, it will capture sounds, including conversations, within the monitoring range. We highly recommend a comprehensive assessment on the potential sound sources in the monitoring range, so as to fully understand the necessity and the reasonableness before you turn on the audio recording function.
3. Video products in use will consistently generate audio or visual data from real scenes –possibly including biometric information such as facial images – based on the user's selection of product features. Such data can be used or processed to use. Video products are only technological tools that do not and cannot humanly practice legal and moral standards to guide lawful and proper use of data. It is the methods and purposes of the people who control and use the generated data that make a difference. Therefore, data controllers shall not only strictly abide by applicable laws and regulations, but also fully respect non-obligatory rules including international conventions, moral standards, cultural norms, public order and local customs. Furthermore, we should always prioritize the protection of privacy and portrait rights, and other reasonable interests.
4. The video data continuously generated by video products carries the rights, values and other demands of various stakeholders. Thus, it is extremely crucial to ensure data security and shield the products from malicious intrusions. Every user and data controller shall, undertake all reasonable and necessary measures to maximize product and data security, avoiding data leakage, improper disclosure or misuse, including but not limited to, setting up access control, selecting a suitable network environment where video products are connected, establishing and constantly optimizing network security.
5. Video products have made great contributions to enhance the safety of our society, and we believe that they will continue to play a positive role in various aspects of our daily life. Any attempt to abuse these products to violate human rights or engage in unlawful activities contradicts the very essence of the value in tech innovation and product development. We encourage every user to establish your own methods and rules to evaluate and monitor the use of video products, so as to ensure that these products are always used properly, thoughtfully and with goodwill.

Appendix

1. Rechargeable Lithium Ion Battery

The battery type of the device: Portable battery.

Hazardous Ingredients (Chemical Name)	CAS No.	Concentration Ranges	Chemical Formula
Nickel-cobalt-manganese lithium	346417-97-8	36.6	LiNiCoMnO ₂
Graphite	7782-42-5	19.8	C
PVDF	24937-79-9	0.4	(CH ₂ -CF ₂) _n
CMC	9000-11-7	0.3	C ₈ H ₁₆ NaO ₈
Acetylene black	1333-86-4	0.9	C
Styrene-butadiene rubber	9003-55-8	0.4	(C ₈ H ₈ .C ₄ H ₆) _x
PP	9003-07-0	0.7	(C ₃ H ₆) _n
Lithium hexafluorophosphate	21324-40-3	2.0	LiF ₆ P
Ethylene carbonate	96-49-1	2.0	C ₃ H ₄ O ₃
Ethyl methyl carbonate	623-53-0	1.0	C ₄ H ₈ O ₃
Dimethyl carbonate	616-38-6	6.8	C ₃ H ₆ O ₃
Copper	7440-50-8	7.6	Cu
Aluminum	7429-90-5	3.5	Al
Nickel	7440-02-0	0.7	Ni
Iron	7439-89-6	17.3	Fe

2. Information for Private Households

1. Separate collection of waste equipment: Electrical and electronic equipment that has become waste is referred to as waste equipment. Owners of waste equipment must dispose of it separately from unsorted municipal waste. In particular, waste equipment does not belong in household waste, but in special collection and return systems.
2. Batteries and rechargeable batteries as well as lamps: Owners of waste equipment shall, as a rule, separate waste batteries and rechargeable batteries that are not enclosed in the waste equipment, which can be removed from the waste equipment without being destroyed, from the waste equipment before handing them in at a collection point. This does not apply if waste equipment is prepared for reuse with the participation of a public waste management authority.
3. Options for returning waste equipment: Owners of waste equipment from private households can return it free of charge to the collection points of the public waste management authorities or to the take-back points set up by manufacturers or distributors within the meaning of the Electrical and Electronics Equipment Law. Stores with a sales area of at least 400 m² for electrical and electronic equipment and those grocery stores with a total sales area of at least 800 m² that offer electrical and electronic equipment several times a year or on a permanent basis and make it available in the market are required to take it back. This also applies in the case of distribution using means of distance communication, if the storage and shipping areas for electrical and electronic equipment are at least 400 m² or the total storage and shipping areas are at least 800 m². Distributors shall, in principle, ensure take-back by providing suitable return facilities at a reasonable distance from the respective end user. The possibility of returning waste equipment free of charge exists for distributors who are obliged to take it back, among other things, if a new similar device that essentially fulfills the same functions is delivered to an end user.
4. Privacy Notice: Waste equipment often contains sensitive personal data. This applies in particular to devices of information and telecommunications technology such as computers and smartphones. In your own interest, please note that each end user is responsible for deleting the data on the waste equipment to be disposed of.
5. Meaning of the symbol "crossed-out wheellie bin": The symbol of a crossed-out wheellie bin regularly depicted on electrical and electronic equipment indicates that the respective device is to be collected separately from unsorted municipal waste at the end of its service life.